

# Water Specialist WS15P Control Valve Parts and Service Manual

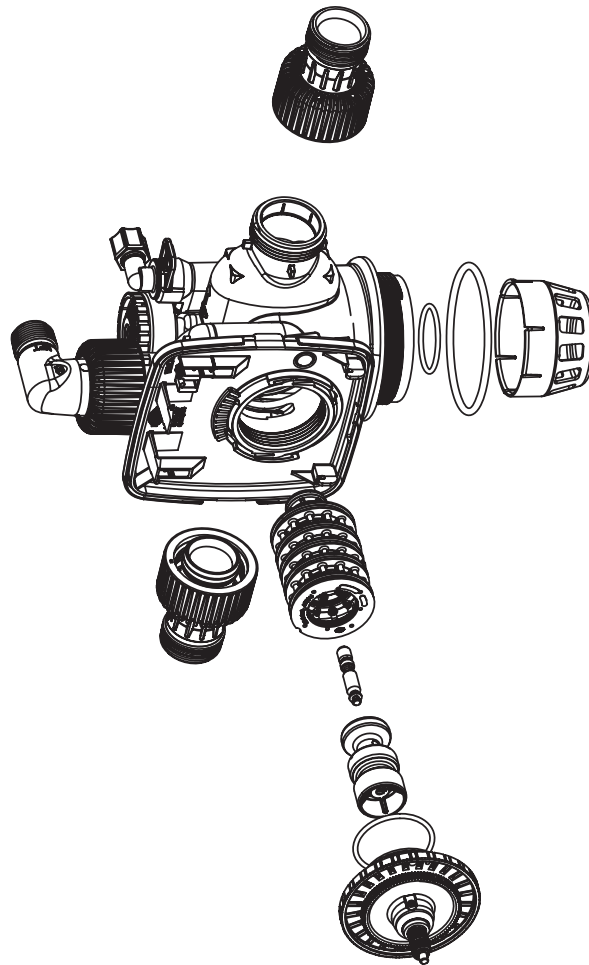

**HYDROCARBONS SUCH AS VASELINE®, PETROLEUM JELLY, KEROSENE, BENZENE, GASOLINE, ETC., WILL DAMAGE PRODUCTS THAT CONTAIN O-RINGS OR PLASTIC COMPONENTS. EXPOSURE TO SUCH HYDROCARBONS MAY CAUSE THE PRODUCTS TO LEAK. DO NOT USE CLACK CONTROL VALVE PRODUCT(S) ON WATER SUPPLIES THAT CONTAIN HYDROCARBONS SUCH AS KEROSENE, BENZENE, GASOLINE, ETC.**





## Table of Contents

General Specifications .....	4
Drive Cap Assembly, Pistons, Stack Assembly, Main Body .....	5
Regenerant Components.....	6
Injectors .....	7
Injector Flow Graphs - U.S. Units.....	8
Injector Flow Graphs - Metric Units .....	9
Fitting Kits.....	10
Drain Line Flow Control Washers.....	11
Troubleshooting Procedures.....	12

### General Specifications

Minimum/Maximum Operating Pressures	20 – 125 psi (138 kPa – 862 kPa)	
Minimum/Maximum Operating Temperatures	40° - 110° F (4° - 43° C)	
Power Adapter: Supply Voltage Supply Frequency Output Voltage Output Current	U.S. 100VAC to 120VAC 50/60 Hz 15VDC 500 mA	International 200VAC to 240VAC 50/60 Hz 15VDC 500 mA
Service flow rate	60 gpm @ 15 psi drop (227 lpm, 13.6 m <sup>3</sup> /h)	
Backwash flow rate	43 gpm @ 25 psi drop (163 lpm, 9.8 m <sup>3</sup> /h)	
Meter: Accuracy Flow Range	±5% 0.75 – 75 gpm (2.8 – 284 lpm)	
Inlet/Outlet	1.5" Male NPT or BSPT	
Drain line	1" Male Elbow NPT or 1" BSPT	
Brine line	½" OD polytube compression	
Tank connection	4"-8 UN	
Height from top of tank	10.75"	
PC board memory	Nonvolatile EEPROM	
Valve material	Glass filled composite	
Regenerant/chemical compatibility	Sodium chloride, potassium chloride, potassium permanganate, sodium bisulfite, chlorine and chloramines	
Regeneration	Downflow or upflow	
Tank applications	12" – 24" diameter	

**WS1.5P Drive Cap Assembly, Pistons, Stack Assembly, Main Body**

Drawing No.	Order No.	Description	Quantity
1	V3004	WS1 DRIVE CAP ASSEMBLY	1
2	V3135	O-RING 228	1
3	V3407	WS125/15 PISTON DOWNFLOW ASSEMBLY (AMBER)	1
	V4042	WS112/15 PISTON UPFLOW ASSEMBLY (BLACK)	
4	V3174*	WS1 REGENERANT PISTON	1
5	V3430-01	WS1.5 SPACER STACK ASSEMBLY	1
6	D1300	TOP BAFFLE DIFFUSER 1.5/55MM	1
7	V3419	O-RING 347	1
8	V4400-NPT	WS15P NPT BODY ASSEMBLY	1
	V4400-BSPT	WS15P BSPT BODY ASSEMBLY	
9	V4430-01**	WS15P FTG ASY QC TO NPT	1 set of 2
	V4430-02**	WS15P FTG ASY QC TO BSPT	
10	V3641	O-RING 225 FOR VALVE BODIES WITH NPT THREADS	1
	V3441	O-RING 226 FOR VALVE BODIES WITH BSPT THREADS	1

\*V3174 Regenerant Piston not used for Backwash Only valves. Use V3010-15Z Injector Plug and V3195-01 Refill Port Plug Assembly.

\*\* Inlet/Outlet fitting kits are sold separate, see page 10 for fitting selection.

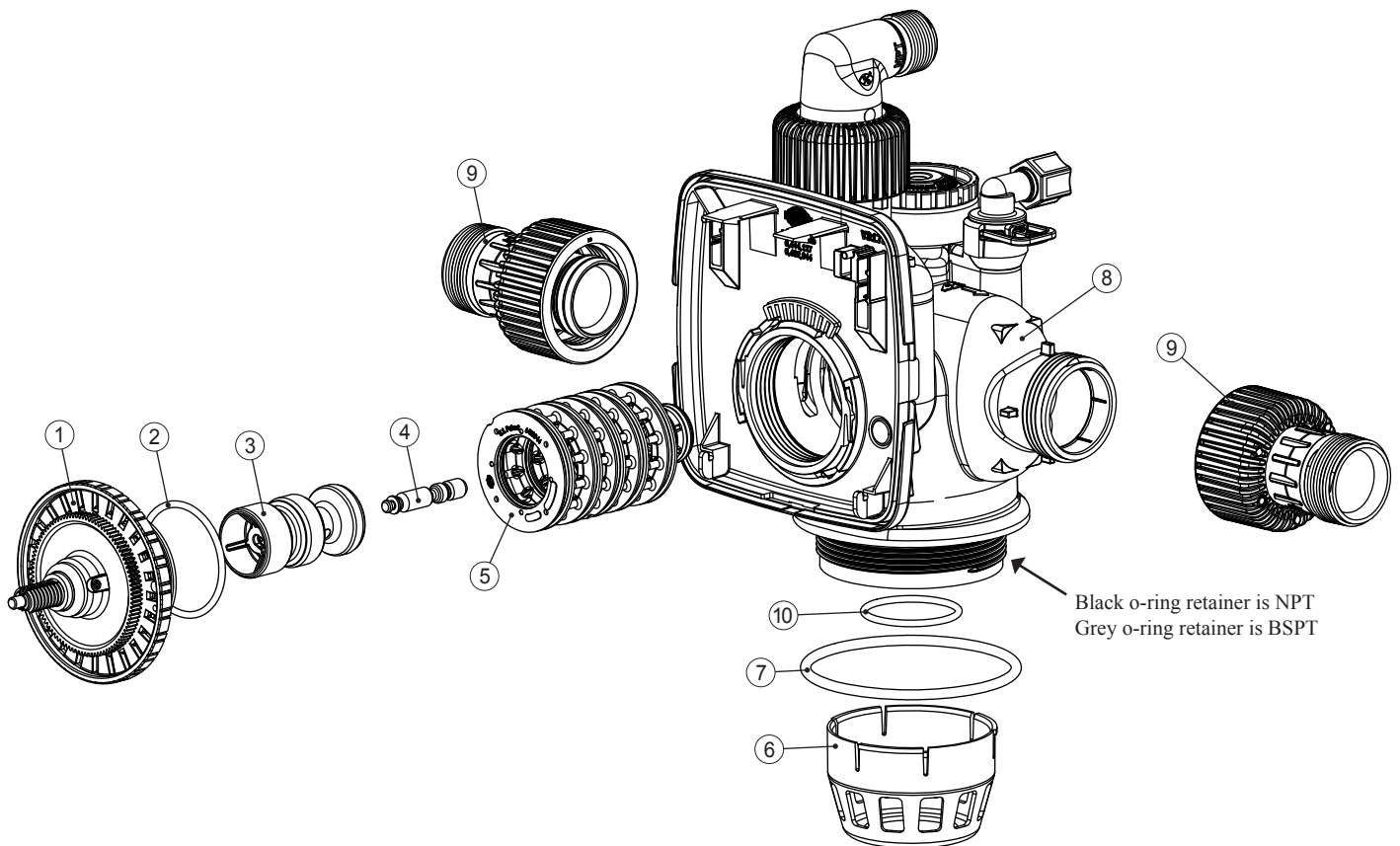

WS15P Regenerant Components

Drawing No.	Order No.	Description	Quantity
1	H4615	RETAINING CLIP	1
2	V3498	WS15 BRINE ELBOW ASY W/RFC ½	1
3	V3195-01	REFILL PORT PLUG ASY	1
4	V4430-04NPT	WS15P NPT DRAIN KIT	1
	V4430-04BSPT	WS15P BSPT DRAIN KIT	

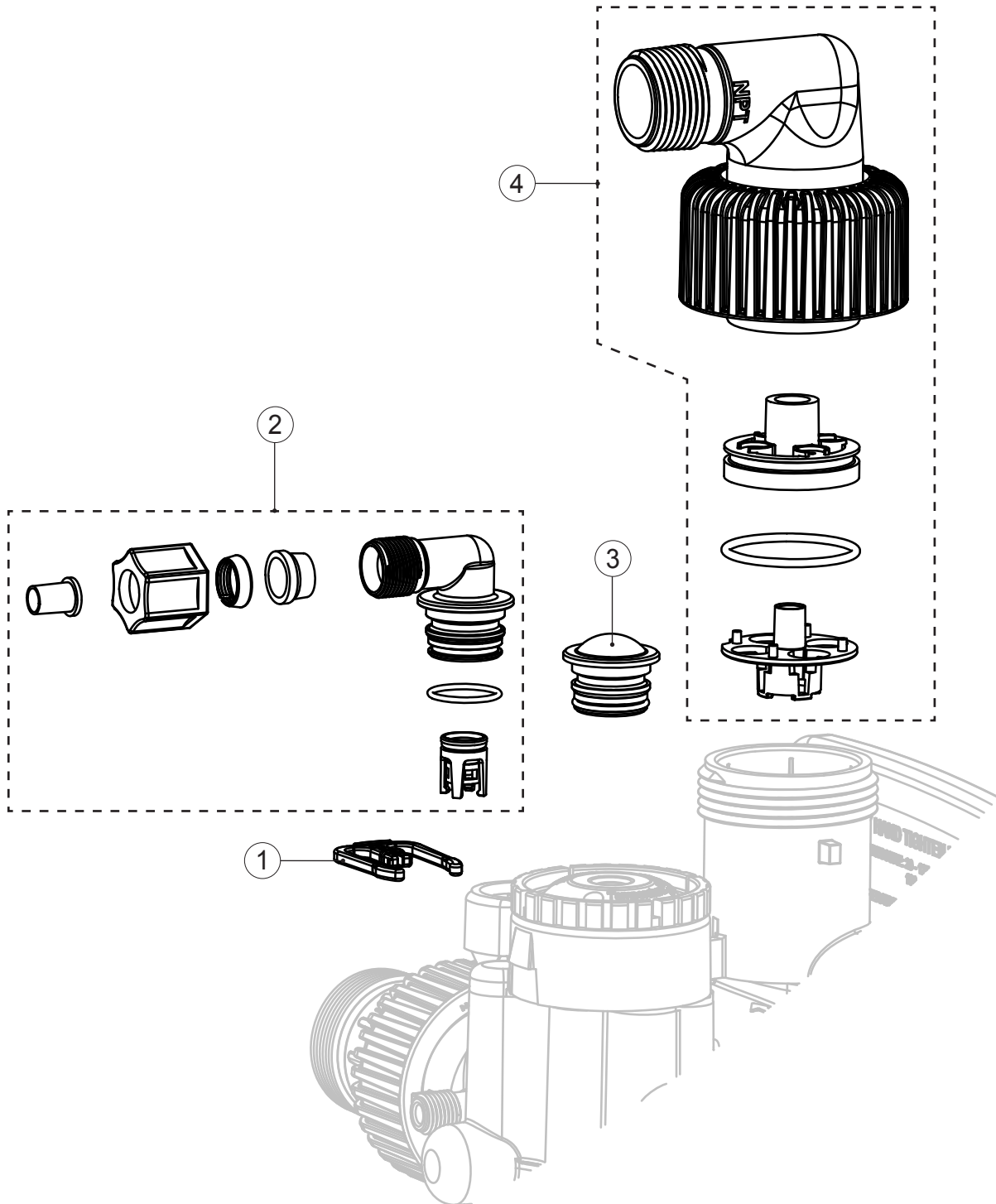

**WS 1.5” Injectors**

Drawing No.	Order No.	Description	Nozzle Color	Downflow Typical Tank Diameter <sup>1</sup>	Quantity
1	V3010-15B	WS1.5 Injector Asy B	Violet	12”	1
	V3010-15C	WS1.5 Injector Asy C	Red	13”	
	V3010-15D	WS1.5 Injector Asy D	White	14”	
	V3010-15E	WS1.5 Injector Asy E	Blue	16”	
	V3010-15F	WS1.5 Injector Asy F	Yellow	18”	
	V3010-15G	WS1.5 Injector Asy G	Green	21”	
	V3010-15H	WS1.5 Injector Asy H	Orange	24”	
2	V3010-15Z	WS1.5 Injector Plug		NA	

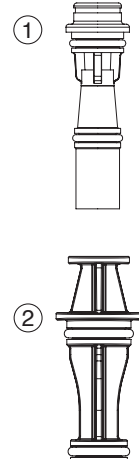

V3010-15B through V3010-15H injectors include one V3416 o-ring 012 (lower) and one V3171 o-ring 013 (upper).

For upflow brine applications, it is recommended that the injector be downsized two tank sizes minimum. Refer to the injector graphs for verifying proper selection.

**WS15P Regenerant Components**

Drawing No.	Order No.	Description	Quantity
1	V4349	WS15P INJECTOR CAP	1
2	V3152	O-RING 135	1
3	V4120	INJECTOR SCREEN	1
4	V4350-15Z	WS15P INJECTOR FEED PLUG	1
5	V3010-15Z	WS15 INJECTOR PLUG ASY	1 or 2
6	V3010-15X	WS15 INJECTOR ASY	1 or 0

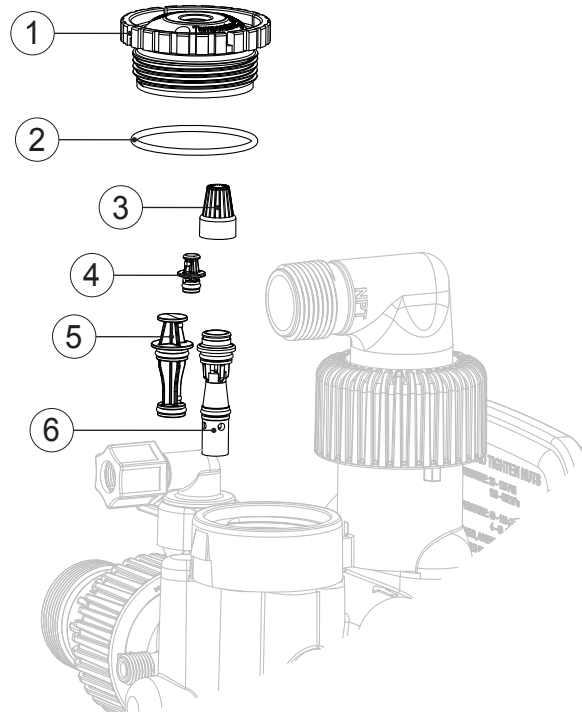

### WS 1.5" Injector Flow Graphs - U.S. Units

ORDER NO. V3010-15B  
VIOLET

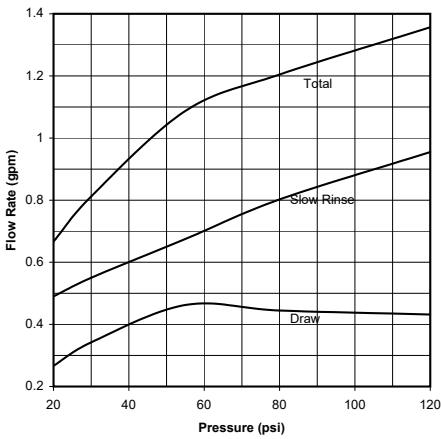

ORDER NO. V3010-15C  
RED

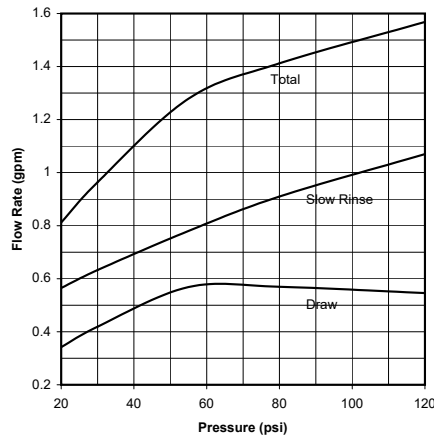

ORDER NO. V3010-15D  
WHITE

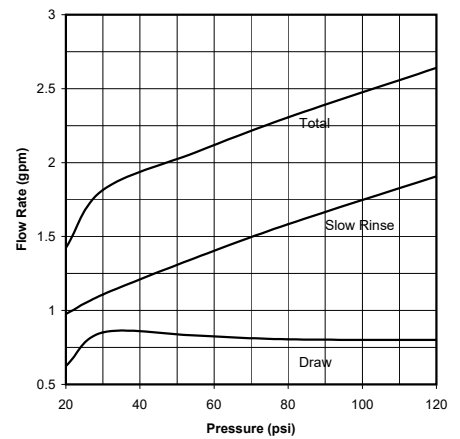

ORDER NO. V3010-15E  
BLUE

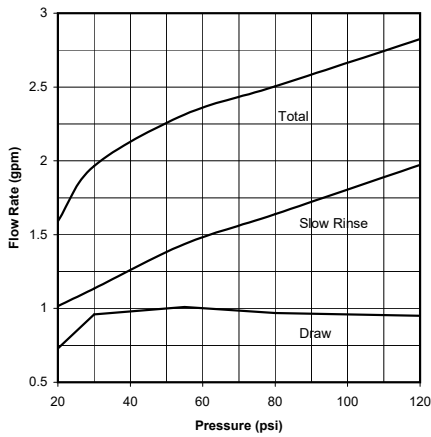

ORDER NO. V3010-15F  
YELLOW

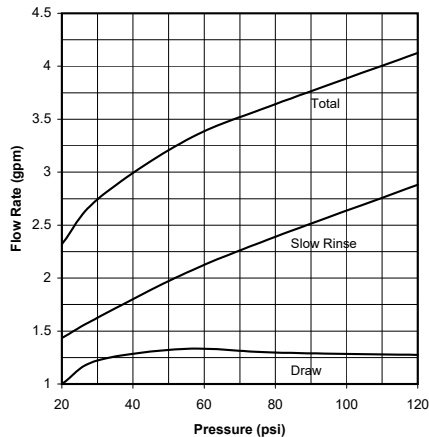

ORDER NO. V3010-15G  
GREEN

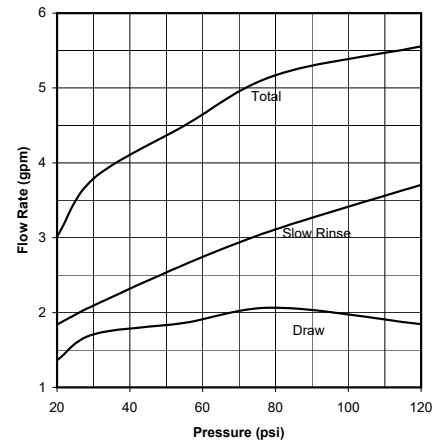

ORDER NO. V3010-15H  
ORANGE

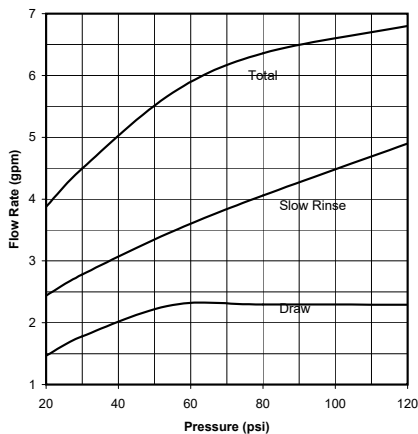

WS 1.5" Injector Flow Graphs - Metric Units

ORDER NO. V3010-15B  
VIOLET

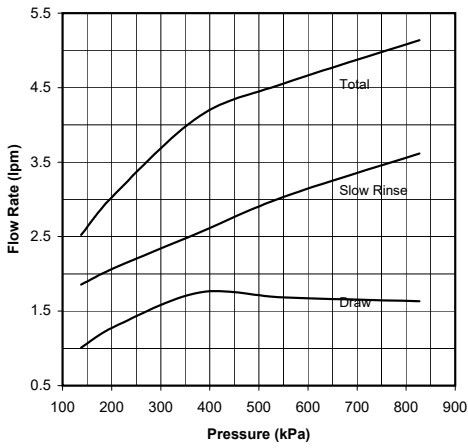

ORDER NO. V3010-15C  
RED

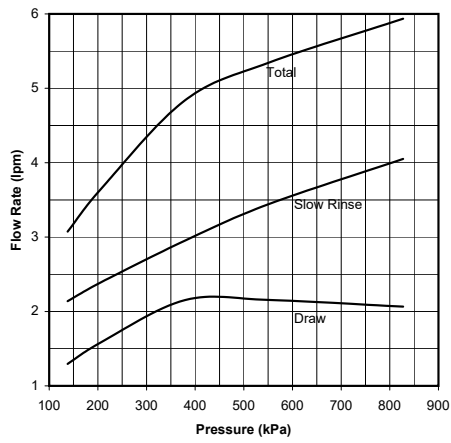

ORDER NO. V3010-15D  
WHITE

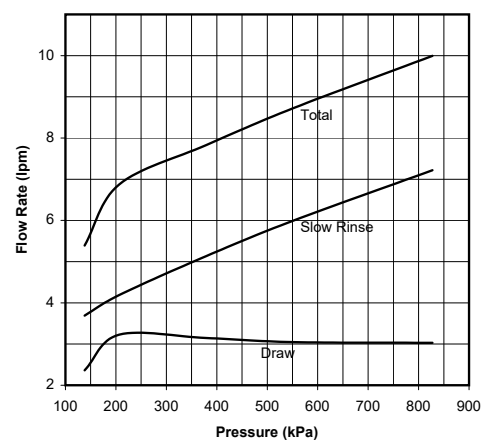

ORDER NO. V3010-15E  
BLUE

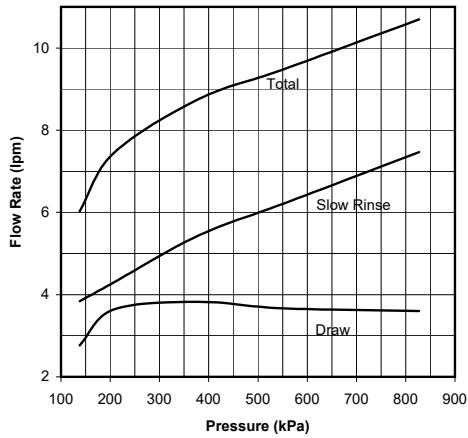

ORDER NO. V3010-15F  
YELLOW

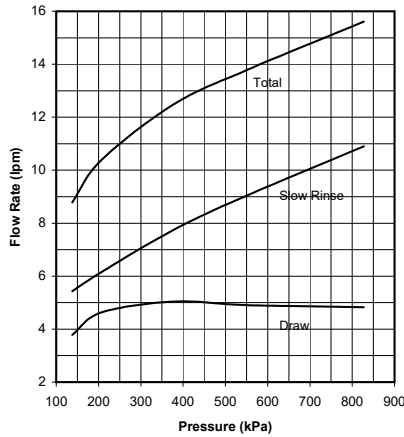

ORDER NO. V3010-15G  
GREEN

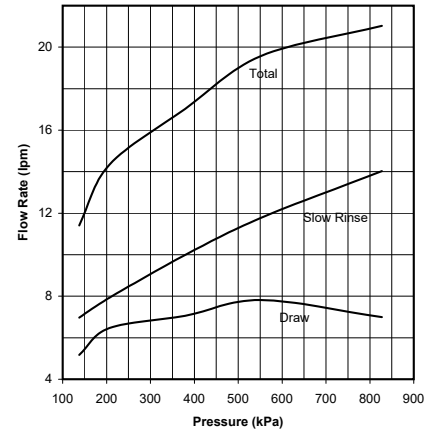

ORDER NO. V3010-15H  
ORANGE

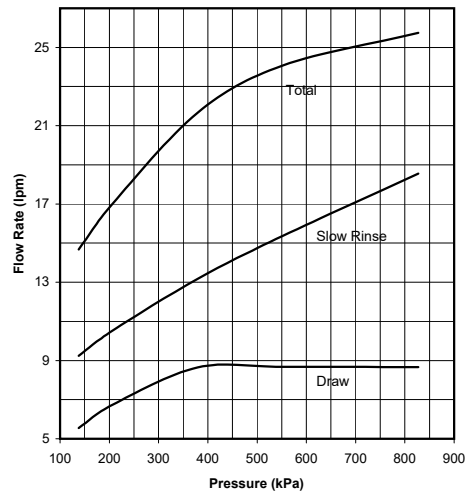

### Fitting Kits

HYDROCARBONS SUCH AS VASELINE®, PETROLEUM JELLY, KEROSENE, BENZENE, GASOLINE, ETC., WILL DAMAGE PRODUCTS THAT CONTAIN O-RINGS OR PLASTIC COMPONENTS. EXPOSURE TO SUCH HYDROCARBONS MAY CAUSE THE PRODUCTS TO LEAK. DO NOT USE CLACK CONTROL VALVE PRODUCT(S) ON WATER SUPPLIES THAT CONTAIN HYDROCARBONS SUCH AS KEROSENE, BENZENE, GASOLINE, ETC.

**Fitting Installation Instructions:**

- Installation fittings are designed to accommodate minor plumbing misalignments, but are not designed to support the weight of a system or the plumbing.
- Teflon tape must be used on the fitting threads.
- Slide nut on first, then the split ring and o-ring.
- Hand tighten the nut only.

**Clack Order No. V4430-01**  
Description: WS15P QC to NPT Fitting Kit

Drawing No.	Order No.	Description	Quantity
1	V4353	WS15P QC TO NPT FITTING	2
2	V4344	WS15P QC NUT	2
3	V4345	WS15P SPLIT RING	2
4	V4367	O-RING 222	2

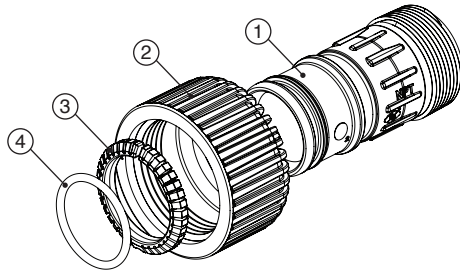

**Clack Order No. V4430-02**  
Description: WS15P QC to BSPT Fitting Kit

Drawing No.	Order No.	Description	Quantity
1	V4355	WS15P QC TO BSPT FITTING	2
2	V4344	WS15P QC NUT	2
3	V4345	WS15P SPLIT RING	2
4	V4367	O-RING 222	2

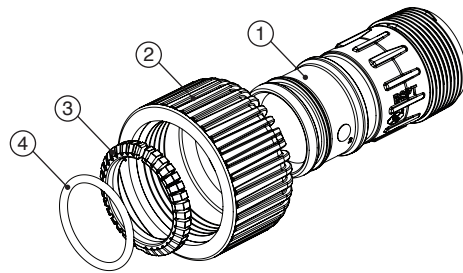

**Clack Order No. V4430-03**  
Description: WS15P QC to QC Fitting Kit

Drawing No.	Order No.	Description	Quantity
1	V4354	WS15P QC TO QC FITTING	1
2	V4344	WS15P QC NUT	2
3	V4345	WS15P SPLIT RING	2
4	V4367	O-RING 222	2

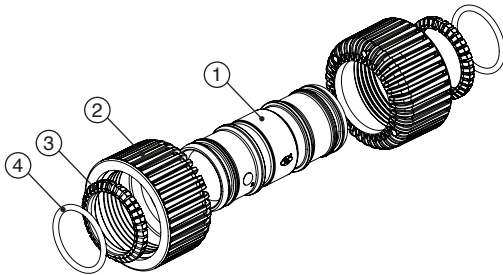

**Clack Order No. V4430-07**  
Description: WS1.5 PLASTIC ELBOW QC TO NPT

Drawing No.	Order No.	Description	Quantity
1	V4432NPT	1.5 PLASTIC QC TO NPT ELBOW	2
2	V4367	O-RING -222	2
3	V4345	1.5 SPLIT RING	2
4	V4344	QC NUT 1.5 PLASTIC	2

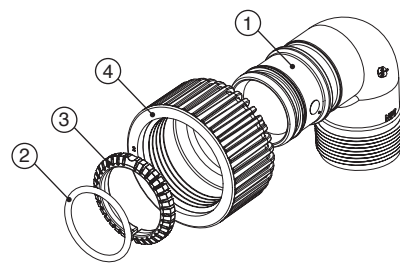

**Clack Order No. V4430-08**  
Description: WS1.5 PLASTIC ELBOW QC TO BSPT

Drawing No.	Order No.	Description	Quantity
1	V4432BSPT	1.5 PLASTIC QC TO BSPT ELBOW	2
2	V4344	QC NUT 1.5 PLASTIC	2
3	V4345	1.5 SPLIT RING	2
4	V4367	O-RING -222	2

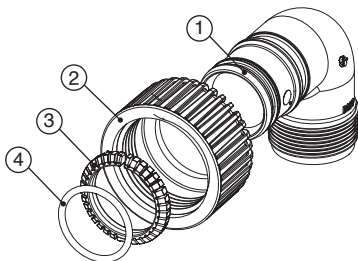

**Clack Order No. V4430-09**  
Description: WS1.5 PLASTIC ELBOW QC TO QC

Drawing No.	Order No.	Description	Quantity
1	V4432QC	1.5 PLASTIC QC TO QC ELBOW	1
2	V4345	1.5 SPLIT RING	2
3	V4344	QC NUT 1.5 PLASTIC	2
4	V4367	O-RING -222	2

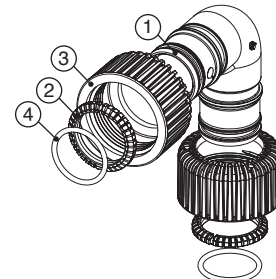

**Drain Line Flow Control Washers**

Order No.	Description
V3162-007	.7 GPM Drain line flow control
V3162-010	1.0 GPM Drain line flow control
V3162-013	1.3 GPM Drain line flow control
V3162-017	1.7 GPM Drain line flow control
V3162-022	2.2 GPM Drain line flow control
V3162-027	2.7 GPM Drain line flow control
V3162-032	3.2 GPM Drain line flow control
V3162-042	4.2 GPM Drain line flow control
V3162-053	5.3 GPM Drain line flow control
V3162-065	6.5 GPM Drain line flow control
V3162-075	7.5 GPM Drain line flow control
V3162-090	9.0 GPM Drain line flow control
V3162-100	10.0 GPM Drain line flow control

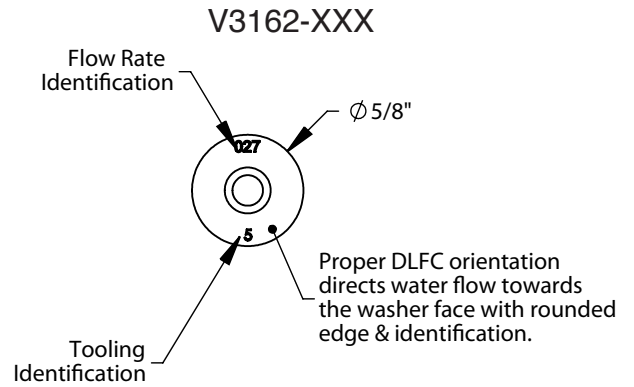

All DLFC housings ship without DLFC installed.  
 Up to 5 x V3162-XXX DLFC may be installed in V4430.  
 Select 1-5 flow controls from table for proper backwash flow,  
 based on media manufacturer's recommendations.

**Click Order No. V4430-04NPT OR V4430-04BSPT  
 Description: WS15P 1.5 Drain Elbow**

Drawing No.	Order No.	Description	Quantity
1A	V4358	WS15P DRAIN ELBOW 1" NPT	1
1B	V4359	WS15P DRAIN ELBOW 1" BSPT	1
2	V4345	WS15P SPLIT RING	1
3	V4344	QC NUT 1.5 PLASTIC	1
4	V4367	O-RING 222	1
5	V4351	FLOW CONTROL HOUSING	1
6	V4352	FLOW CONTROL RETAINER	1
7	V4364	O-RING 129	1

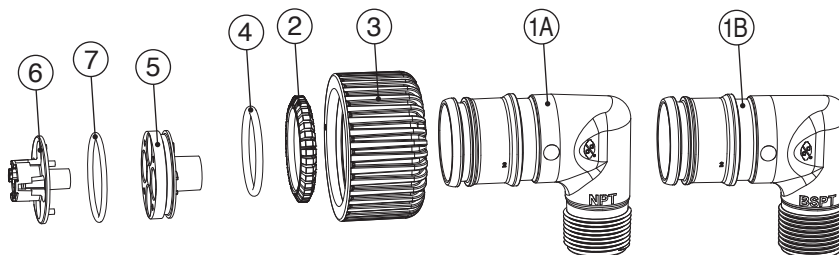

### Troubleshooting Procedures

Problem	Possible Cause	Solution
1. No Display on PC Board	a. No power at electric outlet	a. Repair outlet or use working outlet
	b. Control valve Power Adapter not plugged into outlet or power cord end not connected to PC board connection	b. Plug Power Adapter into outlet or connect power cord end to PC Board connection
	c. Improper power supply	c. Verify proper voltage is being delivered to PC Board
	d. Defective Power Adapter	d. Replace Power Adapter
	e. Defective PC Board	e. Replace PC Board
2. PC Board does not display correct time of day	a. Power Adapter plugged into electric outlet controlled by light switch	a. Use uninterrupted outlet
	b. Tripped breaker switch and/or tripped GFI	b. Reset breaker switch and/ or GFI switch
	c. Power outage	c. Reset time of day. If PC Board has battery back up present the battery may be depleted. See Front Cover and Drive Assembly drawing for instructions.
	d. Defective PC Board	d. Replace PC Board
3. Display does not indicate that water is flowing. Refer to user instructions for how the display indicates water is flowing	a. Bypass valve in bypass position	a. Turn bypass handles to place bypass in service position
	b. Meter is not connected to meter connection on PC Board	b. Connect meter to three pin connection labeled METER on PC Board
	c. Restricted/ stalled meter turbine	c. Remove meter and check for rotation or foreign material
	d. Meter wire not installed securely into three pin connector	d. Verify meter cable wires are installed securely into three pin connector labeled METER
	e. Defective meter	e. Replace meter
	f. Defective PC Board	f. Replace PC Board
4. Control valve regenerates at wrong time of day	a. Power outage	a. Reset time of day. If PC Board has battery back up present the battery may be depleted. See Front Cover and Drive Assembly drawing for instructions.
	b. Time of day not set correctly	b. Reset to correct time of day
	c. Time of regeneration set incorrectly	c. Reset regeneration time
	d. Control valve set at "on 0" (immediate regeneration)	d. Check programming setting and reset to NORMAL (for a delayed regen time)
	e. Control valve set at "NORMAL + on 0" (delayed and/ or immediate)	e. Check programming setting and reset to NORMAL (for a delayed regen time)
5. Time of day flashes on and off	a. Power outage	a. Reset time of day. If PC Board has battery back up present the battery may be depleted. See Front Cover and Drive Assembly drawing for instructions.
6. Control valve does not regenerate automatically when the REGEN button is depressed and held.	a. Broken drive gear or drive cap assembly	a. Replace drive gear or drive cap assembly
	b. Broken Piston Rod	b. Replace piston rod
	c. Defective PC Board	c. Defective PC Board
7. Control valve does not regenerate automatically but <b>does</b> when the REGEN button is depressed and held.	a. Bypass valve in bypass position	a. Turn bypass handles to place bypass in service position
	b. Meter is not connected to meter connection on PC Board	b. Connect meter to three pin connection labeled METER on PC Board
	c. Restricted/ stalled meter turbine	c. Remove meter and check for rotation or foreign material
	d. Incorrect programming	d. Check for programming error
	e. Meter wire not installed securely into three pin connector	e. Verify meter cable wires are installed securely into three pin connector labeled METER
	f. Defective meter	f. Replace meter
	g. Defective PC Board	g. Replace PC Board

Problem	Possible Cause	Solution
8. Hard or untreated water is being delivered	a. Bypass valve is open or faulty	a. Fully close bypass valve or replace
	b. Media is exhausted due to high water usage	b. Check program settings or diagnostics for abnormal water usage
	c. Meter not registering	c. Remove meter and check for rotation or foreign material
	d. Water quality fluctuation	d. Test water and adjust program values accordingly
	e. No regenerant or low level of regenerant in regenerant tank	e. Add proper regenerant to tank
	f. Control fails to draw in regenerant	f. Refer to Trouble Shooting Guide number 12
	g. Insufficient regenerant level in regenerant tank	g. Check refill setting in programming. Check refill flow control for restrictions or debris and clean or replace
	h. Damaged seal/stack assembly	h. Replace seal/stack assembly
	i. Control valve body type and piston type mix matched	i. Verify proper control valve body type and piston type match
	j. Fouled media bed	j. Replace media bed
9. Control valve uses too much regenerant	a. Improper refill setting	a. Check refill setting
	b. Improper program settings	b. Check program setting to make sure they are specific to the water quality and application needs
	c. Control valve regenerates frequently	c. Check for leaking fixtures that may be exhausting capacity or system is undersized
10. Residual regenerant being delivered to service	a. Low water pressure	a. Check incoming water pressure – water pressure must remain at minimum of 25 psi
	b. Incorrect injector size	b. Replace injector with correct size for the application
	c. Restricted drain line	c. Check drain line for restrictions or debris and clean
11. Excessive water in regenerant tank	a. Improper program settings	a. Check refill setting
	b. Plugged injector	b. Remove injector and clean or replace
	c. Drive cap assembly not tightened in properly	c. Re-tighten the drive cap assembly
	d. Damaged seal/ stack assembly	d. Replace seal/ stack
	e. Restricted or kinked drain line	e. Check drain line for restrictions or debris and or un-kink drain line
	f. Plugged backwash flow controller	f. Remove backwash flow controller and clean or replace
	g. Missing refill flow controller	g. Replace refill flow controller
12. Control valve fails to draw in regenerant	a. Injector is plugged	a. Remove injector and clean or replace
	b. Faulty regenerant piston	b. Replace regenerant piston
	c. Regenerant line connection leak	c. Inspect regenerant line for air leak
	d. Drain line restriction or debris cause excess back pressure	d. Inspect drain line and clean to correct restriction
	e. Drain line too long or too high	e. Shorten length and or height
	f. Low water pressure	f. Check incoming water pressure – water pressure must remain at minimum of 25 psi
13. Water running to drain	a. Power outage during regeneration	a. Upon power being restored control will finish the remaining regeneration time. Reset time of day.
	b. Damaged seal/ stack assembly	b. Replace seal/ stack assembly
	c. Piston assembly failure	c. Replace piston assembly
	d. Drive cap assembly not tightened in properly	d. Re-tighten the drive cap assembly

Problem	Possible Cause	Solution
14. E1, Err – 1001, Err – 101 = Control unable to sense motor movement	a. Motor not inserted full to engage pinion, motor wires broken or disconnected	a. Disconnect power, make sure motor is fully engaged, check for broken wires, make sure two pin connector on motor is connected to the two pin connection on the PC Board labeled MOTOR. Press NEXT and REGEN buttons for 3 seconds to resynchronize software with piston position or disconnect power supply from PC Board for 5 seconds and then reconnect.
	b. PC Board not properly snapped into drive bracket	b. Properly snap PC Board into drive bracket and then Press NEXT and REGEN buttons for 3 seconds to resynchronize software with piston position or disconnect power supply from PC Board for 5 seconds and then reconnect.
	c. Missing reduction gears	c. Replace missing gears
15. E2, Err – 1002, Err – 102 = Control valve motor ran too short and was unable to find the next cycle position and stalled	a. Foreign material is lodged in control valve	a. Open up control valve and pull out piston assembly and seal/ stack assembly for inspection. Press NEXT and REGEN buttons for 3 seconds to resynchronize software with piston position or disconnect power supply from PC Board for 5 seconds and then reconnect.
	b. Mechanical binding	b. Check piston and seal/ stack assembly, check reduction gears, check drive bracket and main drive gear interface. Press NEXT and REGEN buttons for 3 seconds to resynchronize software with piston position or disconnect power supply from PC Board for 5 seconds and then reconnect.
	c. Main drive gear too tight	c. Loosen main drive gear. Press NEXT and REGEN buttons for 3 seconds to resynchronize software with piston position or disconnect power supply from PC Board for 5 seconds and then reconnect.
	d. Improper voltage being delivered to PC Board	d. Verify that proper voltage is being supplied. Press NEXT and REGEN buttons for 3 seconds to resynchronize software with piston position or disconnect power supply from PC Board for 5 seconds and then reconnect.
16. E3, Err – 1003, Err – 103 = Control valve motor ran too long and was unable to find the next cycle position	a. Motor failure during a regeneration	a. Check motor connections then Press NEXT and REGEN buttons for 3 seconds to resynchronize software with piston position or disconnect power supply from PC Board for 5 seconds and then reconnect.
	b. Foreign matter built up on piston and stack assemblies creating friction and drag enough to time out motor	b. Replace piston and stack assemblies. Press NEXT and REGEN buttons for 3 seconds to resynchronize software with piston position or disconnect power supply from PC Board for 5 seconds and then reconnect.
	c. Drive bracket not snapped in properly and out enough that reduction gears and drive gear do not interface	c. Snap drive bracket in properly then Press NEXT and REGEN buttons for 3 seconds to resynchronize software with piston position or disconnect power supply from PC Board for 5 seconds and then reconnect.
17. Err – 1004, Err – 104 = Control valve motor ran too long and timed out trying to reach home position	a. Drive bracket not snapped in properly and out enough that reduction gears and drive gear do not interface	a. Snap drive bracket in properly then Press NEXT and REGEN buttons for 3 seconds to resynchronize software with piston position or disconnect power supply from PC Board for 5 seconds and then reconnect.

Problem	Possible Cause	Solution
<p>18. Err -1006, Err – 106, Err - 116 = MAV/ SEPS/ NHBP/ AUX MAV valve motor ran too long and unable to find the proper park position</p> <p>Motorized Alternating Valve = MAV</p> <p>Separate Source = SEPS</p> <p>No Hard Water Bypass = NHBP</p> <p>Auxiliary MAV = AUX MAV</p>	<p>a. Control valve programmed for ALT A or b, nHbP, SEPS, or AUX MAV with out having a MAV or NHBP valve attached to operate that function</p>	<p>a. Press NEXT and REGEN buttons for 3 seconds to resynchronize software with piston position or disconnect power supply from PC Board for 5 seconds and then reconnect. Then re-program valve to proper setting.</p>
	<p>b. MAV/ NHBP motor wire not connected to PC Board</p>	<p>b. Connect MAV/ NHBP motor to PC Board two pin connection labeled DRIVE. Press NEXT and REGEN buttons for 3 seconds to resynchronize software with piston position or disconnect power supply from PC Board for 5 seconds and then reconnect.</p>
	<p>c. MAV/ NHBP motor not fully engaged with reduction gears</p>	<p>c. Properly insert motor into casing, do not force into casing Press NEXT and REGEN buttons for 3 seconds to resynchronize software with piston position or disconnect power supply from PC Board for 5 seconds and then reconnect.</p>
	<p>d. Foreign matter built up on piston and stack assemblies creating friction and drag enough to time out motor</p>	<p>d. Replace piston and stack assemblies. Press NEXT and REGEN buttons for 3 seconds to resynchronize software with piston position or disconnect power supply from PC Board for 5 seconds and then reconnect.</p>
<p>19. Err – 1007, Err – 107, Err - 117 = MAV/ SEPS/ NHBP/ AUX MAV valve motor ran too short (stalled) while looking for proper park position</p> <p>Motorized Alternating Valve = MAV</p> <p>Separate Source = SEPS</p> <p>No Hard Water Bypass = NHBP</p> <p>Auxiliary MAV = AUX MAV</p>	<p>a. Foreign material is lodged in MAV/ NHBP valve</p>	<p>a. Open up MAV/ NHBP valve and check piston and seal/ stack assembly for foreign material. Press NEXT and REGEN buttons for 3 seconds to resynchronize software with piston position or disconnect power supply from PC Board for 5 seconds and then reconnect.</p>
	<p>b. Mechanical binding</p>	<p>b. Check piston and seal/ stack assembly, check reduction gears, drive gear interface, and check MAV/ NHBP black drive pinion on motor for being jammed into motor body. Press NEXT and REGEN buttons for 3 seconds to resynchronize software with piston position or disconnect power supply from PC Board for 5 seconds and then reconnect.</p>







## Revision History:

**2/26/2020**

**PAGE 11:**

1A	V4358	WS15P DRAIN ELBOW 1" NPT	1
1B	V4359	WS15P DRAIN ELBOW 1" BSPT	1

**3/16/2020**

**PAGE 11:**

Removed V3190 series of DLFC from table and V3190-XXX drawing.

**7/6/2020**

**PAGE 11:**

All DLFC housings ship without DLFC installed. Up to 5 x V3162-XXX DLFC may be installed in V4430. Select 1-5 flow controls from table for proper backwash flow, based on media manufacturer's recommendations.

**2/22/2021**

**PAGE 20:**

changed header to read "SOFTENER AND FILTER CONTROLS LIMITED WARRANTY"

**4/21/2022**

**PAGE 5:**

9	V4430-01**	WS15P FTG ASY QC TO NPT	1 set of 2
	V4430-02**	WS15P FTG ASY QC TO BSPT	

\*\* Inlet/Outlet fitting kits are sold separate, see page 10 for fitting selection.

**PAGE 10:**

Added V4430-07, V4430-08 and V4430-09 fittings.

**CLACK CORPORATION  
SOFTENER AND FILTER CONTROLS  
LIMITED WARRANTY**

Clack Corporation ("Clack") warrants to OEM that its Softener and Filter Control Valves will be free from defects in material and workmanship under normal use and service for a period of five years from the date of shipment of such Valves from Clack's plant in Windsor, Wisconsin when installed and operated within recommended parameters. No warranty is made with respect to defects not reported to Clack within the warranty period and/or defects or damages due to neglect, misuse, alterations, accident, misapplication, physical damage, or damage caused by fire, acts of God, freezing or hot water or similar causes. For outdoor installations where the Softener and Filter Control Valves are not under cover, the weather cover must be utilized for the warranty to be valid.

Clack's obligation to OEM under this Limited Warranty shall be limited, at its option, to replacement or repair of any Softener and Filter Control valve covered by this Limited Warranty. Prior to returning a Control Valve, OEM must obtain a return goods authorization number from Clack and return the Control Valve freight prepaid. If any Control Valve is covered under this Limited Warranty, Clack shall return the Control Valve repaired, or its replacement, prepaid to the original point of shipment.

**CLACK GIVES THIS WARRANTY TO OEM IN LIEU OF ALL OTHER WARRANTIES, EXPRESS OR IMPLIED, INCLUDING WITHOUT LIMITATION ANY IMPLIED WARRANTIES OF MERCHANTABILITY OR FITNESS FOR A PARTICULAR PURPOSE AND HEREBY EXPRESSLY DISCLAIMS ALL OTHER SUCH WARRANTIES. CLACK'S LIABILITY HEREUNDER SHALL NOT EXCEED THE COST OF THE PRODUCT. UNDER NO CIRCUMSTANCES WILL CLACK BE LIABLE FOR ANY INCIDENTAL OR CONSEQUENTIAL DAMAGES OR FOR ANY OTHER LOSS, DAMAGE OR EXPENSE OF ANY KIND, INCLUDING LOSS OF PROFITS, ARISING IN CONNECTION WITH THE INSTALLATION OR USE OR INABILITY TO USE THE CONTROL VALVES OR ANY WATER TREATMENT SYSTEM THE CONTROL VALVE IS INCORPORATED INTO.**

Charger Water Treatment Products  
8150 N. Lehigh Ave, Morton Grove, IL 60053  
[www.chargerwater.com/FAQ](http://www.chargerwater.com/FAQ)