



FLECK 9000/9100/9500

SERVICE MANUAL



TABLE OF CONTENTS

JOB SPECIFICATION SHEET.....	2
EQUIPMENT CONFIGURATION.....	2
INSTALLATION & START-UP.....	3
9000/9100/9500 (3200 SERIES) ELECTRO MECHANICAL TIMER ASSEMBLY.....	6
POWER HEAD ASSEMBLY.....	8
9000 CONTROL VALVE ASSEMBLY.....	10
9100 CONTROL VALVE ASSEMBLY.....	13
9500 CONTROL VALVE ASSEMBLY.....	16
1600 BRINE VALVE SYSTEM (FOR 9500).....	19
1700 BRINE VALVE SYSTEM (FOR 9500).....	20
1710 BRINE VALVE SYSTEM (FOR 9500).....	21
3/4-INCH METER ASSEMBLY.....	22
1-INCH METER ASSEMBLY.....	23
1-INCH METER ASSEMBLY.....	24
1-1/2 INCH METER ASSEMBLY.....	25
9000 SECOND TANK ASSEMBLY.....	26
9100 SECOND TANK ASSEMBLY.....	27
9500 SECOND TANK ASSEMBLY.....	28
2300 SAFETY BRINE VALVE.....	29
2310 SAFETY BRINE VALVE.....	30
2310 SAFETY BRINE VALVE.....	31
2350 SAFETY BRINE VALVE.....	32
BYPASS VALVE ASSEMBLY (METAL).....	33
BYPASS VALVE ASSEMBLY (PLASTIC).....	34
GENERAL SERVICE HINTS FOR METER CONTROL.....	35
TROUBLESHOOTING.....	36
9000/9100/9500 METER FLOW DATA.....	37
9000/9100/9500 INJECTOR FLOW DATA (1600 SERIES INJECTORS).....	38
9500 INJECTOR FLOW DATA (1600 & 1700 SERIES INJECTORS).....	39
9000 CONTROL DIMENSIONS.....	40
9100 CONTROL DIMENSIONS.....	41
9500 CONTROL DIMENSIONS.....	42
WATER CONDITIONER FLOW DIAGRAMS.....	43
9000/9500 WIRING DIGRAM.....	45
SERVICE ASSEMBLIES.....	46

CALIFORNIA PROPOSITION 65 WARNING

⚠ WARNING: This product contains chemicals known to the State of California to cause cancer or birth defects or other reproductive harm.

JOB SPECIFICATION SHEET

Job Number: _____
 Model Number: _____
 Water Test: _____
 Capacity Per Unit: _____
 Mineral Tank Size: _____ Diameter: _____ Height: _____
 Brine Tank Size and Salt Setting per Regeneration: _____
 9000/9100/9500 Control Valve Specifications:

- Type of Timer:
 - 82 minute available regeneration time, 1/15 RPM
 - 164 minute available regeneration time, 1/30 RPM
- Meter Size:
 - 3/4- inch Std Range (125 - 2,100 gallon setting)
 - 3/4-inch Ext Range (625 - 10,625 gallon setting)
 - 1-inch Std Range (310 - 5,270 gallon setting)
 - 1-inch Ext Range (1,150 - 26,350 gallon setting)
 - 1-1/2 inches Std Range (625 - 10,625 gallon setting)
 - 1-1/2 inches Ext Range (3,125 - 53,125 gallon setting)
- Timer Gallon Setting: _____ Gallons
- Regeneration Program Setting:
 - Backwash: _____ Minutes
 - Brine and Slow Rinse: _____ Minutes
 - Rapid Rinse: _____ Minutes
 - Brine Tank Refill: _____ Minutes
- Drain Line Flow Control: _____ gpm
- Brine Refill Rate: _____ gpm
- Injector Size: _____

EQUIPMENT CONFIGURATION

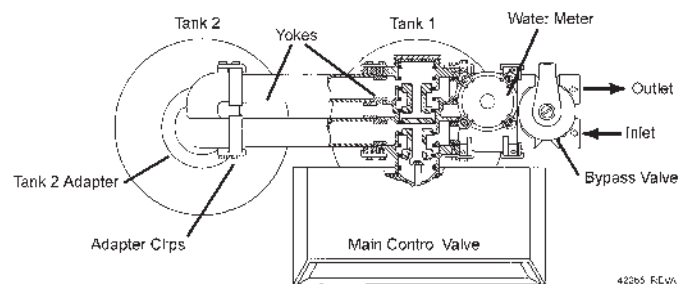

Figure 1 9000/9100 Equipment Configuration

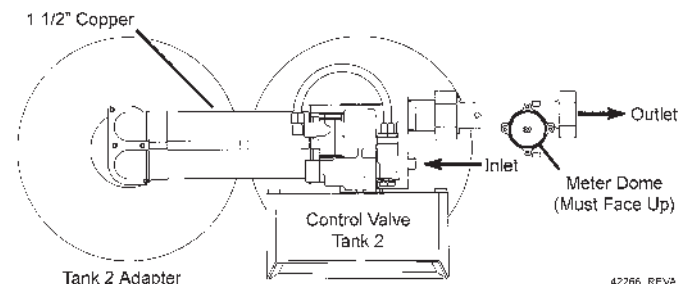

Figure 2 9500 Equipment Configuration

INSTALLATION & START-UP

Water Pressure

A minimum of 25 pounds (1.7 bar) of water pressure is required for regeneration valve to operate effectively.

Electrical Facilities

A continuous 115 volt, 60 Hertz current supply is required. Make certain the current supply is always hot and cannot be turned off with another switch.

Existing Plumbing

Condition of existing plumbing should be free from lime and iron buildup. Piping that is built up heavily with lime and/or iron should be replaced. If piping is clogged with iron, a separate iron filter unit should be installed ahead of the water softener.

Location Of Softener And Drain

The softener should be located close to a drain to prevent air breaks and back flow.

Bypass Valves

Always provide for the installation of a bypass valve.

CAUTION Water pressure is not to exceed 125 psi (8.6 bar), water temperature is not to exceed 110°F (43°C), and the unit cannot be subjected to freezing conditions.

Installation Instructions

1. Place the softener tank where you want to install the unit.

NOTE: Be sure the tank is level and on a firm base.

2. During cold weather, the installer should warm the valve to room temperature before operating.
3. Perform all plumbing according to local plumbing codes.
 - Use a 1/2-inch minimum pipe size for the drain.
 - Use a 3/4-inch drain line for backwash flow rates that exceed 7 gpm or length that exceeds 20 feet (6 m).
4. Both tanks must be the same height and diameter and filled with equal amounts of media.
5. The distributor tube must be flush with the top of each tank. Cut if necessary. Use only non-aerosol silicone lubricant.
6. Lubricate the distributor o-ring seal and tank o-ring seal. Place the main control valve on one tank and the tank adapter on the second tank.

NOTE: If required, solder copper tubing for tank interconnection before assembling on the main control valve and tank adapter. Maintain a minimum of 1 inch distance between tanks on final assembly.

7. **IMPORTANT:** For valves equipped with electromechanical timers and stainless steel meters, refer to the Meter Dome and Union Orientation section.
8. Solder joints near the drain must be done before connecting the Drain Line Flow Control fitting (DLFC). Leave at least 6 inches (152 mm) between the DLFC and solder joints when soldering pipes that are connected on the DLFC. Failure to do this could cause interior damage to DLFC.
9. Use only plumber tape on the drain fitting.
10. Be sure the floor under the salt storage tank is clean and level.

11. Place approximately 1 inch (25 mm) of water above the grid plate. If a grid is not utilized, fill to the top of the air check in the salt tank. Do not add salt to the brine tank at this time.
12. On units with a bypass, place in Bypass position.
13. Turn on the main water supply.
14. Open a cold soft water tap nearby and let water run a few minutes or until the system is free of foreign material (usually solder) resulting from the installation. Close the water tap when water runs clean.
15. Place the bypass In Service position and let water flow into the mineral tank. When water flow stops, slowly open a cold water tap nearby and let water run until air is purged from the unit. Then close tap.
16. Make all electrical connections according to codes. Plug the valve into an approved power source. Do not insert meter cable into the meter yet.
17. Tank one has control valve and tank two has adapter.
18. Look on the right side of the control valve, it has indicators showing which position the control valve is in during Regeneration and which tank is In Service.

NOTE: Make sure the meter cable is not inserted in the meter dome. Swing the timer out to expose the program wheel. To swing timer out, grab onto the lower right corner of timer face and pull outward.

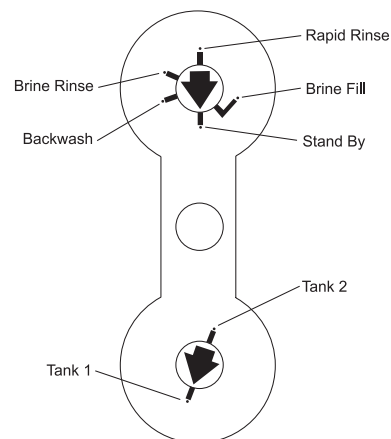
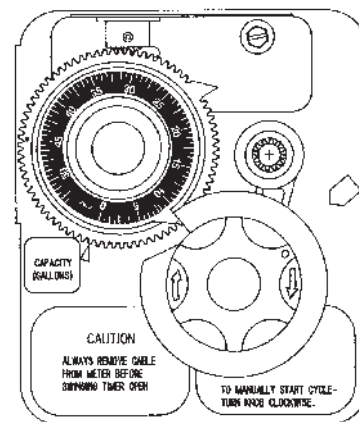

Figure 3 Control Valve Position Indicators



61591 Rev A

Figure 4 Timer

INSTALLATION & STARTUP *CONTINUED*

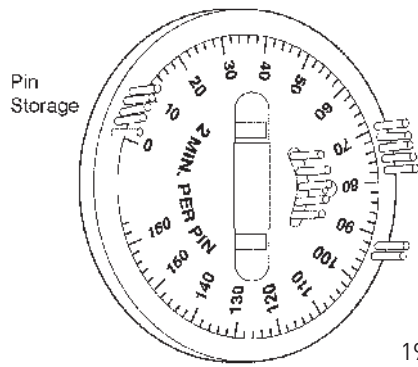

Figure 5 Program Wheel

- Cycle timer into backwash position. Turn manual knob so that the micro switch rides on the first set of pins. In this position the tanks switch (lower piston) and the control valve moves to the backwash position (upper piston). Wait until the positioning of upper and lower pistons stops before advancing the timer further. If advanced too fast the control will not home into the In Service position (it will not advance to any other position). To correct this, rotate the manual knob back to In Service and start again into backwash.

NOTE: Once valve positions itself into the backwash cycle, the homing circuit locks in.

- With all the air backwashed, slowly cycle the timer to the brine position; rapid rinse; and brine tank refill. Wait for the control drive motor to position itself in each cycle and stop, before advancing on to the next position.
- Once back in the In Service position, cycle the control valve again into the backwash position. The tanks switch again, and air head backwashes out of the other tank. Cycle the control back to the In Service position. Leave the timer in the open position. DO NOT insert meter cable yet.

NOTE: Two motors are available.
1/15 RPM has 82 minute regeneration time.
1/30 RPM has 164 minute regeneration time.

Valve To Tank Installation

- Spin the valve onto the tank, ensuring the threads are not cross-threaded.

NOTE: All Fleck® valves are right-hand threads, or clockwise, to install

- Rotate the valve freely without using force until it comes to a stop (this position is considered zero).
- Rotate the valve clockwise from zero, between 1/4-turn and 1/2-turn (see "Figure 6").

NOTE: If lubricant is required, a silicone compound is strongly recommended. Dow Corning® Silicone Compound (available from Pentair), is recommended for best possible results. Dow Corning® 7 Release Compound is used in the manufacture of Pentair control valves. The use of other types of lubricants may attack the control's plastic or rubber components. Petroleum-based lubricants can cause swelling in rubber parts, including o-rings and seals.

Part No.	Description
16174	Silicone, 2 oz Tube
16586-8	Silicone, Dow #7 8 lb

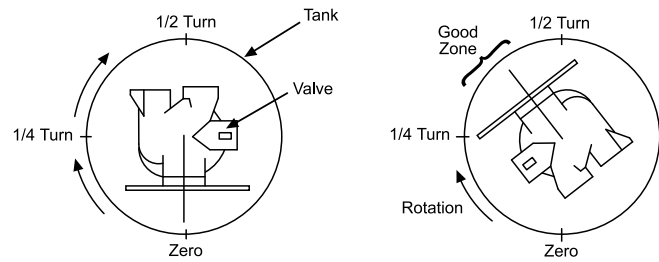

Figure 6

Setting the Regeneration Cycle Program

The Regeneration cycle program on the water conditioner is preset at the factory. However, portions of the cycle or program time may be lengthened or shortened for local conditions or system design.

- Expose cycle program wheel by grasping timer in lower right hand corner and pulling. This releases snap retainer and swings timer to the left

NOTE: Meter cable must be removed from meter dome before opening timer.

- Remove the program wheel by grasping program wheel and squeezing protruding lugs towards center. Lift program wheel off timer. Switch arms may require movement to facilitate removal.
- Return timer to closed position by engaging snap retainer in back plate. Make certain all electrical wires locate above snap retainer post.

Changing Length of the Backwash Time

Looking at the numbered side of the program wheel, the group of pins starting at zero determines the length of time the unit backwashes.

Example: If there are six pins in this section, the time of backwash is 12 minutes (2 minutes per pin). To change the length of backwash time, add or remove pins as required.

The number of pins multiplied by two equals minutes of backwash.

Changing Length of Brine and Rinse Time

The group of holes between the last pin in the backwash section and the second group of pins determines the length of time that a unit will brine and rinse (2 minutes per hole).

To change the length of brine and rinse time, add or remove pins in the rapid rinse group of pins to increase or decrease the number of holes in the brine and rinse section.

The number of holes multiplied by two equals minutes of brine and rinse.

Changing Length Of Rapid Rinse

The second group of pins on the program wheel determines the length of time the water conditioner rapid rinses (2 minutes per pin). To change the length of rapid rinse time, add or remove pins at the higher numbered end of this section as required.

The number of pins multiplied by two equals minutes of rapid rinse.

NOTE: Program wheels with 0-82 minute cycle times, use one minute per pin or hole to set Regeneration times. The layout of pins and holes on the program wheel follow the same procedure as on this page.

INSTALLATION & STARTUP *CONTINUED*

Changing Length of Brine Tank Refill Time

The second group of holes on the program wheel determines the length of time the water conditioner refills the brine tank (2 minutes per hole).

To change the length of refill time, move the two pins at the end of the second group of holes as required.

The Regeneration cycle is complete when the two pin set at end of the brine tank refill section trips the outer micro-switch. The program wheel, however, continues to rotate until the inner micro-switch drops into the notch on the program wheel.

Programming

1. The control valve is set at the factory for backwash; brine and slow rinse; rapid rinse and brine tank fill times. Change any of these times by repositioning the pins and holes or adding more pins.

NOTE: Two timer motors are available.

1/15 RPM has 82 minute Regeneration Time and each pin or hole equals one minute.

1/30 RPM has 164 minute Regeneration Time and each pin or hole equals two minutes.

2. The control valve has a separate brine tank fill cycle. Calculate the desired salt setting using the brine line flow control rate of refill (in gpm) multiplied by the timer setting. Then, using one gallon of fresh water dissolving approximately 3 lbs salt, calculate the refill time.

Example: A desired 30 lbs salt setting:

The unit has a 1.0 gpm refill rate so a 10 gallon fill is required.

$$10 \text{ gallons} \times 3 \text{ lbs/gals} = 30 \text{ lbs salt}$$

Set the timer refill section at 10 minutes.

$$10 \text{ minutes} \times 1.0 \text{ gpm} = 10 \text{ gallon fill}$$

NOTE: There must always be two pins at the end of a refill time to stop the fill cycle. With the Regeneration times set, place timer back to its original position, making sure the lower right hand corner snaps back into the backplate and the meter cable slides through the backplate and does not bind.

3. Setting the gallon wheel. Knowing the amount of resin in each tank and the salt setting per Regeneration, calculate the gallons available, using the following capacities as a guide:

$$\frac{(\text{capacity per ft}^3 \times \text{ft}^3 \text{ of resin per tank})}{\text{compensated hardness of H}_2\text{O}} = \text{gallons available}$$

NOTE: Based on tank size: More resin increases capacity, less resin decreases capacity. More salt increases capacity, less salt decreases capacity.

Example:

Tank Diameter	=	16 inches
Compensated Hardness	=	35 grains per gallon (tested sample)
ft ³ Resin (based on flow rate)	=	4
lbs of Salt per ft ³	=	8
Capacity per ft ³	=	24,000
$\frac{[24,000 \times 4 \text{ ft}^3 \text{ of resin per tank}]}{35 \text{ grains}}$	=	2,740 gallons available before regeneration

Complete step 4 before setting gallons on the meter wheel.

4. Because the control valve regenerates with soft water from the other tank, subtract the water used for regeneration. Take each regeneration cycle and calculate the water used.

Example: Unit is set for a 16-inch diameter tank with 4 ft³ of resin and salted at 8 lbs. per ft³, 7 gpm backwash, #3 injector, 1.0 gpm brine refill, and 60 psi and timer set for 10 min. backwash, 60 min. brine and rinse, 10 min. rapid rinse, 10 min. brine tank fill.

$$\text{Backwash} \quad 10 \text{ min} \times 7.0 \text{ gpm} = 70.0 \text{ gal}$$

$$\text{Brine and Rinse} \quad 60 \text{ min} \times 1.0 \text{ gpm} = 60.0 \text{ gal}$$

$$\text{Rapid Rinse} \quad 10 \text{ min} \times 7.0 \text{ gpm} = 70.0 \text{ gal}$$

$$\text{Brine Tank Fill} \quad 10 \text{ min} \times 1.0 \text{ gpm} = 10.0 \text{ gal}$$

$$\text{Total Regeneration Water} \quad = 210.0 \text{ gal}$$

With the 2740 gallons available calculated in Step 3, subtract the Regeneration water used from the total water available.

$$2740 \text{ gallons available} - 210 \text{ gallons used} = 2530 \text{ gallons (in Regeneration, Step 4)}$$

5. Set meter wheel at approximately 2530 gallons. Lift the inner dial of the meter program wheel so that you can rotate it freely. Position the white dot opposite the 2530 gallon setting.

NOTE: There is a slight delay between the time the meter zeros out and the cycle starts. Units using the: 1/15 RPM motor, 82 minute Regeneration Time has a 9 minute delay 1/30 RPM motor, 180 minute Regeneration Time has an 18 minute delay.

NOTE: This delay period is not critical on residential equipment. However, take this factor into consideration for commercial applications by subtracting continuous flows for 9 minutes or 18 minutes from water available.

6. Insert meter cable into meter.
7. Check bypass.
8. Plug in unit.

INSTALLATION *CONTINUED*

Meter Dome and Union Orientation

Control valves outfitted with an electromechanical timer and stainless steel water meter include a special male x female threaded stainless steel union to insure proper installation and operation of the water meter.

⚠ WARNING: The location of this union in relation to the control valve and water meter is critical for proper operation. DO NOT omit or substitute this special union; it positions the meter dome at the correct distance from the control valve and allows re-positioning the water meter dome for proper operation.

1. Apply a suitable thread sealant to the male threads of the union and meter body.
2. Thread the union into the OUTLET port of the control valve, then thread the meter into the union. See illustrations below.
3. Rotate the water meter body so the meter dome is at the 12 o'clock position. Loosen the nut on the union to facilitate this if required. Once in position, tighten the union nut.
4. Connect the meter cable to the open port in the center of the meter dome.
5. Continue with the installation of the control valve.

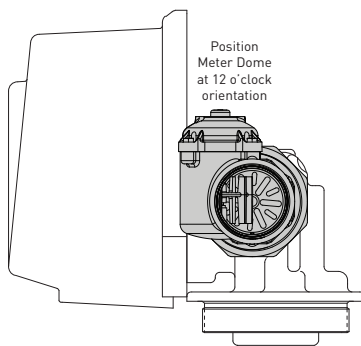
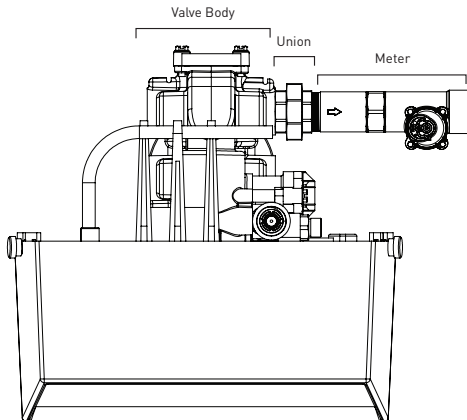

9000/9100/9500 (3200 SERIES) ELECTRO MECHANICAL TIMER ASSEMBLY

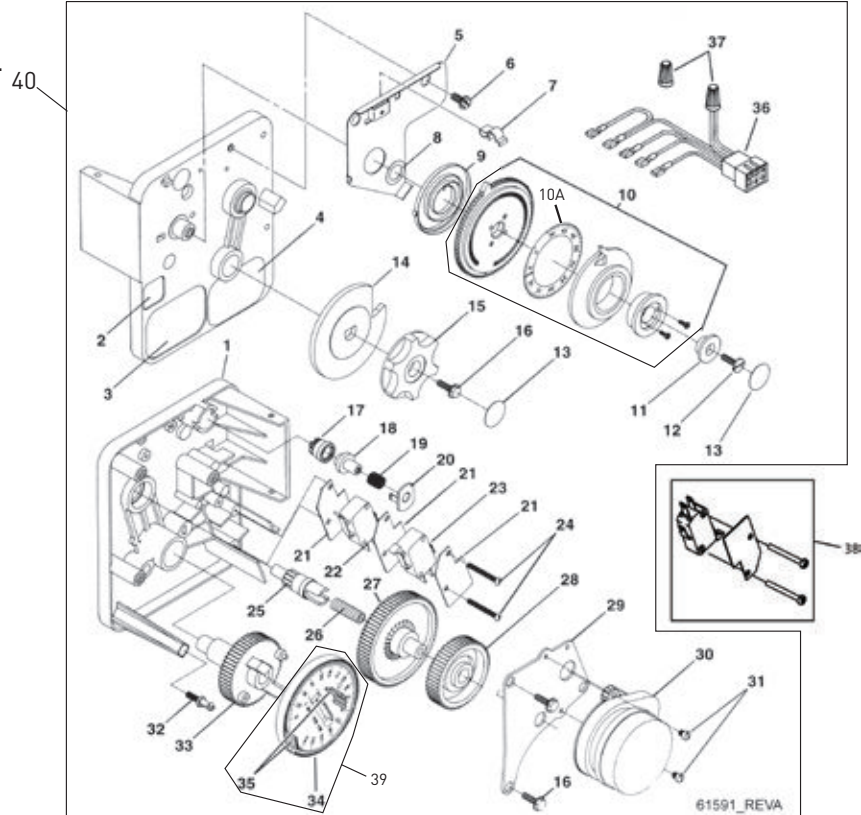

9000/9100/9500 (3200 SERIES) ELECTRO MECHANICAL TIMER ASSEMBLY *CONTINUED*

Item No.	QTY	Part No.	Description	Item No.	QTY	Part No.	Description
1	1	13870-03	Housing, Timer, 9000	21	3	14087	Insulator
2	1	17870	Label, Indicator, 9000 Timer	22	1	15314	Switch, Micro, Modified
3	1	15465	Label, Caution	23	1	15320	Switch, Micro, Timer
4	1	16930	Label, Instruction	24	2	11413	Screw, Pan Hd Mach, 4-40 x 1 1/8
5	1	15227	Plate, Clutch, Actuator	25	1	13018	Pinion, Idler
6	1	10300	Screw, Slot Hex Washer, 18-8 x 3/8	26	1	18563	Spring, Idler Shaft
7	1	17513	Clip, Spring	27	1	13017	Gear, Idler
8	1	15407	Washer, Plain, #4	28	1	13164	Gear, Drive
9	1	15228	Spring, Return	29	1	13887	Plate, Motor Mounting
10	1	16270-10	Program Wheel Assy, 9000/9100, 3/4-inch STD, 0-2, 100	30	1	18743-1	Motor, 120V, 60 Hz 1/30 RPM, 5600
		16270-30	Program Wheel Assy, 9000/9100, 1-inch STD, 0-5, 100			18824-1	Motor, 230V, 50 Hz 1/30 RPM
		16270-40	Program Wheel Assy, 9000/9100, 1-inch EXT, 0-25, 500			19170	Motor, 120V 60 Hz 1/15 RPM
		16270-50	Program Wheel Assy, 9000/9100/9500, 3/4-inch EXT, 1.5-inch STD, 0-10, 500			18825	Motor, 230V, 50 Hz 1/15 RPM Mallory
		16270-60	Program Wheel Assy, 9500, 1.5-inch EXT, 0-50, 000	31	2	13278	Screw, Phil Hd Mach, 6-32 x 1/8 Steel Zinc
10A		24673	Volume Label, Metric, 9000/9100, 3/4-inch STD, 0-8m ³	32	1	14265	Clip, Spring
		24672	Volume Label, Metric, 9000/9100, 1-inch STD, 0-20m ³	33	1	15055	Timer, Main Drive Gear
		24676	Volume Label, Metric, 9000/9100, 1-inch EXT, 0-100m ³	34	1	19210-02	Program Wheel Assy, 9000 1/15
		24675	Volume Label, Metric, 9000/9100/9500, 3/4-inch EXT, 1.5-inch STD 0-40m ³			19210-05	Program Wheel Assy, 9000/3230
		25027	Volume Label, Metric, 9500, 1.5-inch EXT, 1.5-inch EXT 0-200m ³	35	23	15493	Pin, Spring, 1/16 x 5/8 SS
11	1	13806	Retainer, Program Wheel	36	1	15203	Harness, 9000/9500, Timer
12	1	13748	Screw, Flt Hd St, 6-20 x 1/2	37	2	40422	Nut, Wire, Tan
13	2	11999	Label, Button	38	1	60320-02	Switch Kit, 3200/9000 Timer Auxiliary
14	1	15223	Actuator, Cycle	39		61420-69	Program Wheel & Gear Assy, 5-30-5-10-2, 2 Min Per Pin
15	1	13886	Know, 3200			61420-80	Program Wheel & Gear Assy, 5-40-5-7-2, 2 Min Per Pin
16	4	13296	Screw, Hex Washer, 6-20 x 1/2	40	1	*	Complete 9000 Meter Immediate Timer Assembly
17	1	17724	Program Wheel, Pinion Drive	*Call your distributor for Part Number			
18	1	17723	Clutch, Drive Pinion				
19	1	14276	Spring, Meter Clutch				
20	1	14253	Retainer, Clutch Spring				

POWER HEAD ASSEMBLY

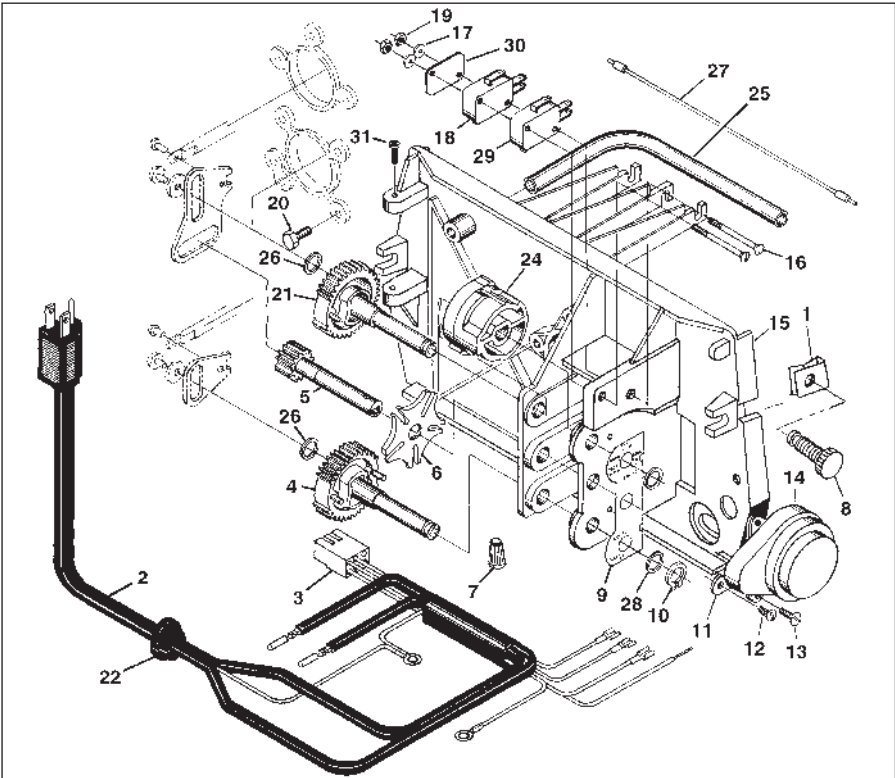

POWER HEAD ASSEMBLY *CONTINUED*

Item No.	QTY	Part No.	Description	Item No.	QTY	Part No.	Description
1	2	18728	Nut, Tinnerman, U Type, 8-32	17	2	10340	Washer, Lock #4, Zinc
2	1	11838	Power Cord, 6' Fleck	18	2	16433	Switch, Miniature
		11839	Power Cord, 12' Fleck	19	1	10339	Nut, Hex, 4-40 Zinc Plated
		40084-12	Power Cord, 12' U.S., Round, 120V Sys 5, 6, 7 & 2900/3150/3900 #4	20	1	15331	Screw, Hex Washer Mach, 10-24 x 3/4 410 S.S.
		19885-01	Power Cord Assy, Japanese	21	1	15133	Gear Assy, Drive, 3/4-inch Stroke
		11545-01	Power Cord Assy, 4' Black, Euro w/Terminals	22	1	13547	Strain Relief, Flat Cord Heyco #30-1
		14678	Power Cord, U.S., 220/60		1	13547-01	Strain Relief, Round Cord
		19303-01	Power Cord Assy, Australian w/Terminals	23	1	15810	Ring, Retaining
		40085-12	Power Cord, 12' US, Round, 240V	24	1	17331	Cam, 9000, 9100, 9500
		44147	Transformer, US, 24V, 9.6VA, Lvl6			17765	Cam Assy, Aux Switch, 9000, 9100, 9500
		41475	Transformer, 24V, 9.6VA, European	25	1	15368	Tube, Cable Guide, 2-Tank, 9000/9100
3	1	15202	Harness, 9000/9500, Drive			17337	Tube, Cable Guide, 9500
		14822	Harness, 2900	26	2	15372	Washer, Thrust, 3/8
4	1	15134	Gear Assy, Drive, 1/2-inch Stroke 9000/9500	27	1	15425	Meter Cable Assy, 13.25 inches 9000/9100 3/4-inch STD & EXT
5	1	15135	Gear, Drive, 9000			15216	Meter Cable Assy, 15.25 inches 9000/9100 1-inch STD & EXT
6	1	14896	Wheel, Geneva			17744	Meter Cable Assy, 20.75 inches 9500 1.5-inch STD & EXT
7	2	40422	Nut, Wire, Tan	28	2	15692	Washer, Plain, 3/8-inch
8	2	19367	Screw, Designer Cover, Thumb 8-32 Blank UV Stable Material	30	1	10302	Insulator, Limit Switch
9	1	15175	Label, Shaft Position	31	2	15173	Screw, Slot Rd Hd Mach, 5-20 x 3/8
10	2	14917	Ring, Retaining	32		*	Complete 9000/9100/9500 Powerhead Assy
11	1	42296	Plate, Ground, 9000/9500	Not Shown			
12	1	14430	Screw, Hex Washer St, 6 x 1/4 Type "B"	1		60232-110	Cover, Designer, 1 Pc Black
13	2	19160	Screw, Phil Pan, Thread 6-32 x 3/8 Type 23 Zinc	1		60232-112	Cover, Designer, 1 Pc Black w/Left Window, Electric
14	1	18737	Motor, 24V, 50/60 Hz, 1 RPM	1		60320-10	Switch Assy, Drive Cam, 9000, 9100, 9500
		18738	Motor, 120V, 50/60 Hz 1 RPM	*Call your distributor for Part Number			
		18739	Motor, 220V, 50/60 Hz 1 RPM				
15	1	15131	Backplate, 9000, Mechanical, SXT				
		17784-05	Panel, Control, 9000/9500 XT				
		17784-02	Panel, Control, 9000, 9500 w/Terminal Block				
16	2	15172	Screw, Flt Hd Mach, 4-40 x 1 3/8 Steel Zinc Plate				

9000 CONTROL VALVE ASSEMBLY

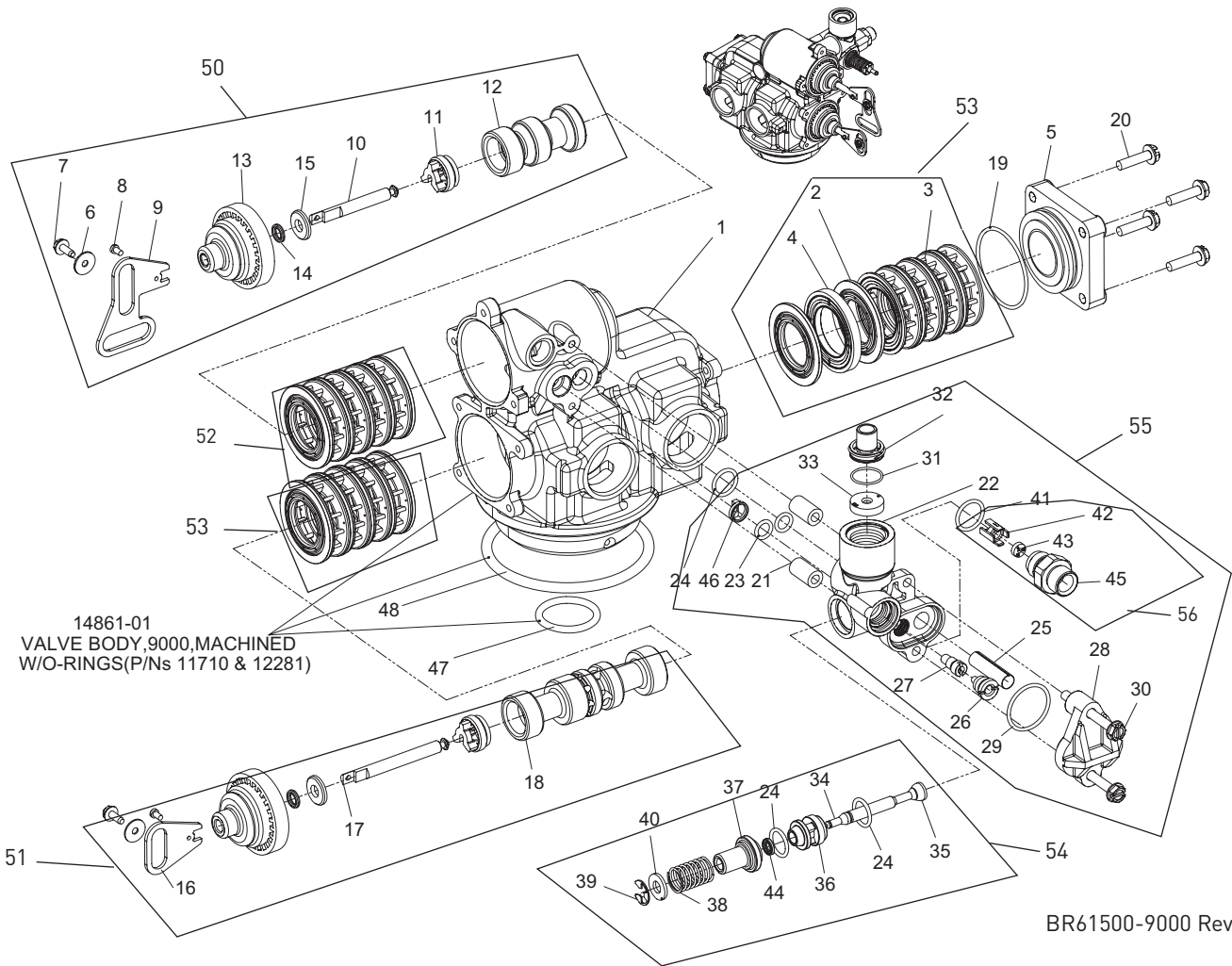

9000 CONTROL VALVE ASSEMBLY *CONTINUED*

Item No.	QTY	Part No.	Description	Item No.	QTY	Part No.	Description
1	1	14861	Valve Body, 9000	33	1	19153	Washer, Flow, 0.6 GPM
2	16	13242-02	Seal, 5600,9000, 9100			19152	Washer, Flow, 0.8 GPM
3	12	14241	Spacer, 5600,9000, 9100			12097	Washer, Flow, 1.0 GPM
4	1	16595	Spacer, 9000, 9100			12085	Washer, Flow, 1.2 GPM
5	1	43458	End Cap, Plastic, 9000/9100			19150	Washer, Flow, 1.3 GPM
6	2	13363	Washer, Plain			12086	Washer, Flow, 1.5 GPM
7	2	17020	Screw, STL. Hex Washer, 6-20 x 3/8			19149	Washer, Flow, 1.7 GPM
8	2	11335	Screw, #4-40			12087	Washer, Flow, 2.0 GPM
9	1	14921	Link, Piston Rod			12088	Washer, Flow, 2.4 GPM
10	1	14919	Piston, Rod, Upper			12089	Washer, Flow, 3.0 GPM
11	2	14309	Retainer, Piston Rod			12090	Washer, Flow, 3.5 GPM
12	1	14914	Piston, 9000, 9100 Upper			12091	Washer, Flow, 4.0 GPM
13	2	13243	Plug, End, 5600, 9000, 9100			19147	Washer, Flow, 4.5 GPM
14	2	10209	Quad Ring, -010			12092	Washer, Flow, 5.0 GPM
15	2	13008	Retainer, End Plug Seal			17814	Washer, Flow, 6.0 GPM
16	1	15019	Link, Piston Rod, 9000/9500, 9100	34	1	14925	Brine Valve Stem, 9000, 9100
17	1	14920	Rod, Piston, Lower, 9000, 9100	35	1	12626	Seat, Brine Valve
18	1	14905	Piston, 9000, 9100 Lower	36	1	13167	Spacer, Brine Valve
19	1	40952	O-ring, -030	37	1	13165	Cap, Brine Valve
20	4	15331	Screw, Hex Washer Head	38	1	11973	Spring, Brine Valve
21	2	13361	Spacer, 4600, 9000, 9100	39	1	11981-01	Ring, Retaining, SS
22	1	15215	Body, Injector, 9000, 9100	40	1	16098	Washer, Nylon Brine
23	2	13301	O-ring, -011	41	1	12977	O-ring, -015
24	3	13302	O-ring, -014	42	1	13245	Retainer, BLFC
25	1	10227	Screen, Injector	43	1	17307	Washer, Flow, 0.125 GPM
26	1	10913-000	Nozzle, Injector, #000, Brown			12094	Washer, Flow, 0.25 GPM
		10913-00	Nozzle, Injector, #00, Violet			12095	Washer, Flow, 0.50 GPM
		10913-0	Nozzle, Injector, #0, Red			12097	Washer, Flow, 1.0 GPM
		10913-1	Nozzle, Injector, #1, White	44	1	12550	Quad Ring, -009
		10913-2	Nozzle, Injector, #2, Blue	45	1	13244	Adapter, BLFC
		10913-3	Nozzle, Injector, #3, Yellow	46	1	13497	Air Disperser, Injector
		10913-4	Nozzle, Injector, #4, Green	47	1	11710	O-ring, -215
27	1	10914-000	Throat, Injector, #000, Brown	48	1	12281	O-ring, -338
		10914-00	Throat, Injector, #00, Violet	50		60400	Piston Assy, 9000, 9100 Upper
		10914-0	Throat, Injector, #0, Red			60400-01	Piston Assy, 9000 Upper, HW
		10914-1	Throat, Injector, #1, White			60400-001	Piston Assy, 9000, 9100 Upper, 560CD
		10914-2	Throat, Injector, #2, Blue	51		60401	Piston Assy, 9000, 9100 Lower
		10914-3	Throat, Injector, #3, Yellow			60401-01	Piston Assy, 9000 Lower, HW
		10914-4	Throat, Injector, #4, Green			60401-001	Piston Assy, 9000, 9100 Lower, 560CD
28	1	13166	Cap, Injector, 5600, 9000, 9100	52		60125	Seal & Spacer Kit, 5600/9000/9100 Upper
29	1	13303	O-ring, -021			60125-15	Seal & Spacer Kit, 5600/9000/9100 Upper Blue
30	2	13387	Screw, Hex Washer Head			60125HW	Seal & Spacer Kit, 9000 Upper
31	1	15348	O-ring, -563				
32	1	13173	Retainer, DLFC Button				

9000 CONTROL VALVE ASSEMBLY *CONTINUED*

Item No.	QTY	Part No.	Description	Item No.	QTY	Part No.	Description
53		60421	Seal & Spacer Kit, 9000/9100 Lower			60385-0382	Injector Drain, 9000, 9100, 0.50 BLFC #3 INJ, 5.0 DLFC
		60421HW	Seal & Spacer Kit, 9000 Lower			60385-0482	Injector Drain, 9000, 9100, 0.50 BLFC #4 INJ, 5.0 DLFC
		60421-50	Seal & Spacer Kit, 9000/9100 Lower, 559PE			60385-0133	Injector Drain, 9000, 9100, 1.0 BLFC #1 INJ, 2.0 DLFC
54		60350	Brine Valve Assy, 9000, 9100			60385-0143	Injector Drain, 9000, 9100, 1.0 BLFC #1 INJ, 2.4 DLFC
		60350-01	Brine Valve Assy, 9000, 560CD, Hot Water			60385-0163	Injector Drain, 9000, 9100, 1.0 BLFC #1 INJ, 3.5 DLFC
55		60385-0011	Injector Drain, 9000, 9100, 0.25 BLFC #0 INJ, 1.2 DLFC			60385-0233	Injector Drain, 9000, 9100, 1.0 BLFC #2 INJ, 2.0 DLFC
		60385-0111	Injector Drain, 9000, 9100, 0.25 BLFC #1 INJ, 1.2 DLFC			60385-0243	Injector Drain, 9000, 9100, 1.0 BLFC #2 INJ, 2.4 DLFC
		60385-0121	Injector Drain, 9000, 9100, 0.25 BLFC #1 INJ, 1.5 DLFC			60385-0253	Injector Drain, 9000, 9100, 1.0 BLFC #2 INJ, 3.0 DLFC
		60385-0131	Injector Drain, 9000, 9100, 0.25 BLFC #1 INJ, 2.0 DLFC			60385-0263	Injector Drain, 9000, 9100, 1.0 BLFC #2 INJ, 3.5 DLFC
		60385-0141	Injector Drain, 9000, 9100, 0.25 BLFC #1 INJ, 2.4 DLFC			60385-0273	Injector Drain, 9000, 9100, 1.0 BLFC #2 INJ, 4.0 DLFC
		60385-0012	Injector Drain, 9000, 9100, 0.50 BLFC #0 INJ, 1.2 DLFC			60385-0353	Injector Drain, 9000, 9100, 1.0 BLFC #3 INJ, 3.0 DLFC
		60385-0112	Injector Drain, 9000, 9100, 0.50 BLFC #1 INJ, 1.2 DLFC			60385-0373	Injector Drain, 9000, 9100, 1.0 BLFC #3 INJ, 4.0 DLFC
		60385-0122	Injector Drain, 9000, 9100, 0.50 BLFC #1 INJ, 1.5 DLFC			60385-0383	Injector Drain, 9000, 9100, 1.0 BLFC #3 INJ, 5.0 DLFC
		60385-0132	Injector Drain, 9000, 9100, 0.50 BLFC #1 INJ, 2.0 DLFC			60385-0393	Injector Drain, 9000, 9100, 1.0 BLFC #3 INJ, 7.0 DLFC
		60385-0142	Injector Drain, 9000, 9100, 0.50 BLFC #1 INJ, 2.4 DLFC	56		60022-12	BLFC, 0.125 GPM, 5000/5600/9000/9100
		60385-0182	Injector Drain, 9000, 9100, 0.50 BLFC #1 INJ, 5.0 DLFC			60022-25	BLFC, 0.25 GPM, 5000/5600/9000/9100
		60385-0222	Injector Drain, 9000, 9100, 0.50 BLFC #2 INJ, 1.5 DLFC			60022-50	BLFC, 0.50 GPM, 5000/5600/9000/9100
		60385-0242	Injector Drain, 9000, 9100, 0.50 BLFC #2 INJ, 2.4 DLFC			60022-100	BLFC, 1.0 GPM, 5000/5600/9000/9100
		60385-0252	Injector Drain, 9000, 9100, 0.50 BLFC #2 INJ, 3.0 DLFC	Not Shown			
		60385-0262	Injector Drain, 9000, 9100, 0.50 BLFC #2 INJ, 3.5 DLFC	1		12128	Label, 0.25 GPM BLFC
		60385-0272	Injector Drain, 9000, 9100, 0.50 BLFC #2 INJ, 4.0 DLFC	1		13333	Label, Injector
		60385-0282	Injector Drain, 9000, 9100, 0.50 BLFC #2 INJ, 5.0 DLFC	1		10760	Label, 1 GPM, 3 lbs salt/min
		60385-02A2	Injector Drain, 9000, 9100, 0.50 BLFC #2 INJ, 6.0 DLFC			10759	Label, 0.5 GPM, 1.5 lbs Salt
		60385-0202	Injector Drain, 9000, 9100, 0.50 BLFC #2 INJ, Blank DLFC			19654	Label, 0.125 GPM Brine Refill Flow
		60385-0372	Injector Drain, 9000, 9100, 0.50 BLFC #3 INJ, 4.0 DLFC				

9100 CONTROL VALVE ASSEMBLY

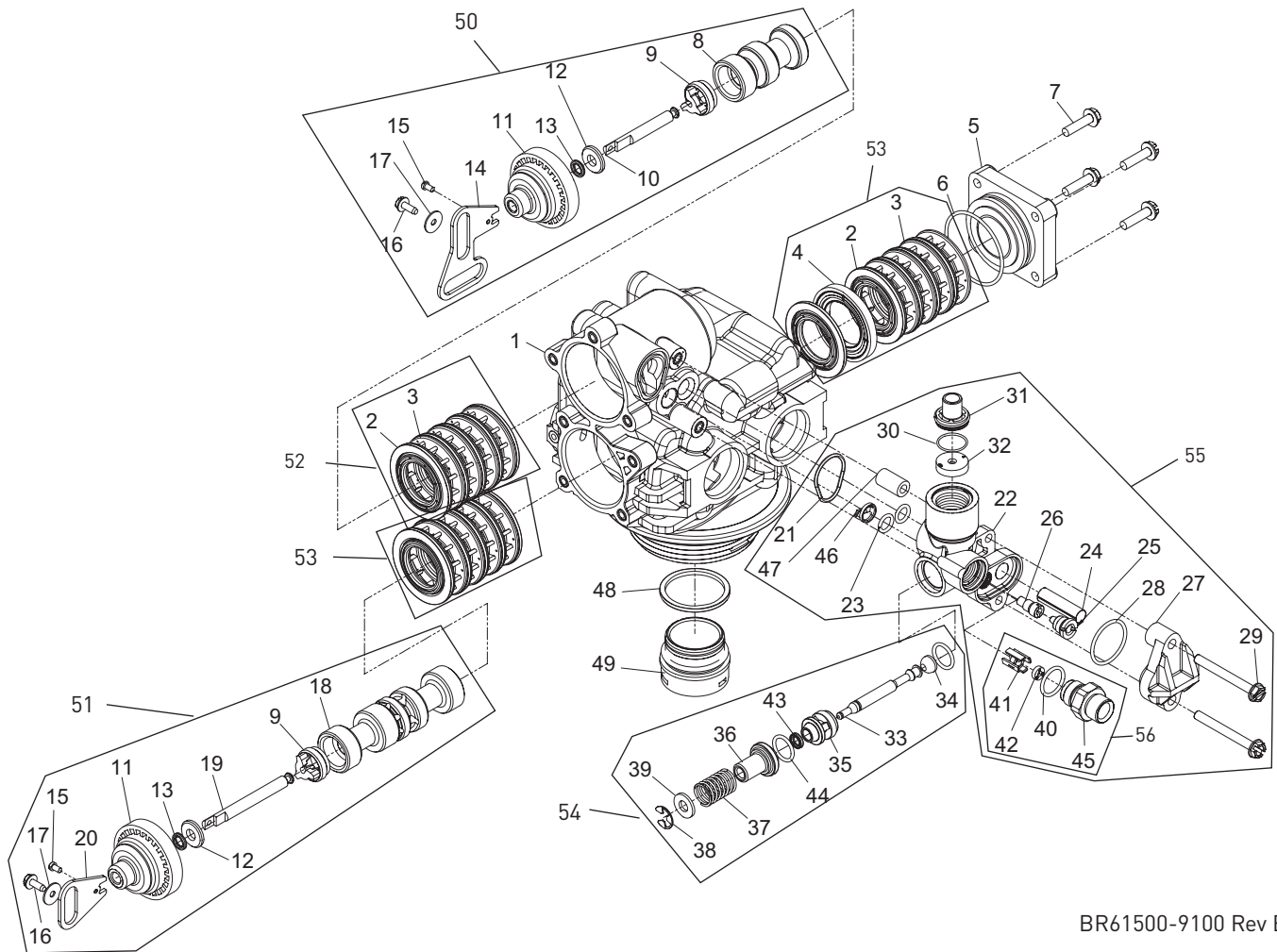

BR61500-9100 Rev E

Item No.	QTY	Part No.	Description
1	1	40688	Valve Body Assy, 9100
2	16	13242-02	Seal, 5600,9000, 9100
3	12	14241	Spacer, 5600,9000, 9100
4	1	16595	Spacer, 9000, 9100
5	1	43458	End Cap, Plastic, 9000/9100
6	1	40952	O-ring, -030
7	4	15331	Screw, Hex Washer Head
8	1	14914	Piston, 9000, 9100 Upper
9	2	14309	Retainer, Piston Rod
10	1	14919	Piston, Rod, Upper
11	2	13243	Plug, End, 5600, 9000, 9100
12	2	13008	Retainer, End Plug Seal
13	2	10209	Quad Ring, -010
14	1	14921	Link, Piston Rod
15	2	11335	Screw, #4-40
16	2	17020	Screw, STL. Hex Washer, 6-20 x 3/8

Item No.	QTY	Part No.	Description
17	2	13363	Washer, Hague Drive
18	1	14905	Piston, 9000, 9100 Lower
19	1	14920	Rod, Piston, Lower, 9000, 9100
20	1	15019	Link, Piston, Rod, 9000/9500
21	1	41500	O-ring, 9100 Drain
22	1	15215	Body, Injector, 9000, 9100
23	2	13301	O-ring, -011
24	1	10227	Screen, Injector
25	1	10913-000	Nozzle, Injector, #000, Brown
		10913-00	Nozzle, Injector, #00, Violet
		10913-0	Nozzle, Injector, #0, Red
		10913-1	Nozzle, Injector, #1, White
		10913-2	Nozzle, Injector, #2, Blue
		10913-3	Nozzle, Injector, #3, Yellow
		10913-4	Nozzle, Injector, #4, Green

9100 CONTROL VALVE ASSEMBLY *CONTINUED*

Item No.	QTY	Part No.	Description	Item No.	QTY	Part No.	Description
26	1	10914-000	Throat, Injector, #000, Brown	47	1	13361	Spacer, 4600, 9100
		10914-00	Throat, Injector, #00, Violet	48	1	40538	Retainer, 32 mm, O-ring DIST, 7000
		10914-0	Throat, Injector, #0, Red	49	1	61419	Kit, 1.05-inch Distributor Adapter
		10914-1	Throat, Injector, #1, White	50		60400	Piston Assy, 9000, 9100 Upper
		10914-2	Throat, Injector, #2, Blue			60400-001	Piston Assy, 9000, 9100 Upper, 560CD
		10914-3	Throat, Injector, #3, Yellow	51		60401	Piston Assy, 9000, 9100 Lower
		10914-4	Throat, Injector, #4, Green			60401-01	Piston Assy, 9000 Lower, HW
27	1	13166	Cap, Injector, 5600, 9000, 9100			60401-001	Piston Assy, 9000, 9100 Lower, 560CD
28	1	13303	O-ring, -021	52		60125	Seal & Spacer Kit, 5600/9000/9100 Upper
29	2	13387	Screw, Hex Washer Head			60125-15	Seal & Spacer Kit, 5600/9000/9100 Upper Blue Silicone
30	1	15348	O-ring, -563	53		60421	Seal & Spacer Kit, 9000/9100 Lower
31	1	13173	Retainer, DLFC Button			60421-50	Seal & Spacer Kit, 9000/9100 Lower, 559PE
32	1	19153	Washer, Flow, 0.6 GPM	54		60350	Brine Valve Assy, 9000, 9100
		19152	Washer, Flow, 0.8 GPM	55		60385-0011	Injector Drain, 9000, 9100, 0.25 BLFC #0 INJ, 1.2 DLFC
		12097	Washer, Flow, 1.0 GPM			60385-0111	Injector Drain, 9000, 9100, 0.25 BLFC #1 INJ, 1.2 DLFC
		12085	Washer, Flow, 1.2 GPM			60385-0121	Injector Drain, 9000, 9100, 0.25 BLFC #1 INJ, 1.5 DLFC
		19150	Washer, Flow, 1.3 GPM			60385-0131	Injector Drain, 9000, 9100, 0.25 BLFC #1 INJ, 2.0 DLFC
		12086	Washer, Flow, 1.5 GPM			60385-0141	Injector Drain, 9000, 9100, 0.25 BLFC #1 INJ, 2.4 DLFC
		19149	Washer, Flow, 1.7 GPM			60385-0012	Injector Drain, 9000, 9100, 0.50 BLFC #0 INJ, 1.2 DLFC
		12087	Washer, Flow, 2.0 GPM			60385-0112	Injector Drain, 9000, 9100, 0.50 BLFC #1 INJ, 1.2 DLFC
		12088	Washer, Flow, 2.4 GPM			60385-0122	Injector Drain, 9000, 9100, 0.50 BLFC #1 INJ, 1.5 DLFC
		12089	Washer, Flow, 3.0 GPM			60385-0132	Injector Drain, 9000, 9100, 0.50 BLFC #1 INJ, 2.0 DLFC
		12090	Washer, Flow, 3.5 GPM			60385-0142	Injector Drain, 9000, 9100, 0.50 BLFC #1 INJ, 2.4 DLFC
		12091	Washer, Flow, 4.0 GPM			60385-0182	Injector Drain, 9000, 9100, 0.50 BLFC #1 INJ, 5.0 DLFC
		19147	Washer, Flow, 4.5 GPM			60385-0222	Injector Drain, 9000, 9100, 0.50 BLFC #2 INJ, 1.5 DLFC
		12092	Washer, Flow, 5.0 GPM			60385-0242	Injector Drain, 9000, 9100, 0.50 BLFC #2 INJ, 2.4 DLFC
		17814	Washer, Flow, 6.0 GPM			60385-0252	Injector Drain, 9000, 9100, 0.50 BLFC #2 INJ, 3.0 DLFC
		12408	Washer, Flow, 7.0 GPM			60385-0262	Injector Drain, 9000, 9100,
33	1	14925	Brine Valve Stem, 9000, 9100				
34	1	12626	Seat, Brine Valve				
35	1	13167	Spacer, Brine Valve				
36	1	13165	Cap, Brine Valve				
37	1	11973	Spring, Brine Valve				
38	1	11981-01	Ring, Retaining, SS				
39	1	16098	Washer, Nylon Brine				
40	1	12977	O-ring, -015				
41	1	13245	Retainer, BLFC				
42	1	17307	Washer, Flow, 0.125 GPM				
		12094	Washer, Flow, 0.25 GPM				
		12095	Washer, Flow, 0.50 GPM				
		12097	Washer, Flow, 1.0 GPM				
43	1	12550	Quad Ring, -009				
44	2	13302	O-ring, -014				
45	1	13244	Adapter, BLFC				
46	1	13497	Air Dispenser, Injector				

9100 CONTROL VALVE ASSEMBLY *CONTINUED*

Item No.	QTY	Part No.	Description	Item No.	QTY	Part No.	Description
			0.50 BLFC #2 INJ, 3.5 DLFC			60022-50	BLFC, 0.50 GPM, 5000/5600/9000/9100
		60385-0272	Injector Drain, 9000, 9100, 0.50 BLFC #2 INJ, 4.0 DLFC			60022-100	BLFC, 1.0 GPM, 5000/5600/9000/9100
		60385-0282	Injector Drain, 9000, 9100, 0.50 BLFC #2 INJ, 5.0 DLFC	Not Shown			
		60385-02A2	Injector Drain, 9000, 9100, 0.50 BLFC #2 INJ, 6.0 DLFC	1		13333	Label, Injector
		60385-0202	Injector Drain, 9000, 9100, 0.50 BLFC #2 INJ, Blank DLFC	1		10759	Label, 0.5 GPM, 1.5 lbs salt/ min
		60385-0372	Injector Drain, 9000, 9100, 0.50 BLFC #3 INJ, 4.0 DLFC			18569	Retainer, Tank Seal
		60385-0382	Injector Drain, 9000, 9100, 0.50 BLFC #3 INJ, 5.0 DLFC			18303	O-ring, -336, Top of Tank
		60385-0482	Injector Drain, 9000, 9100, 0.50 BLFC #4 INJ, 5.0 DLFC			12128	Label, 0.25 GPM BLFC
		60385-0133	Injector Drain, 9000, 9100, 1.0 BLFC #1 INJ, 2.0 DLFC			10760	Label 1 GPM, 3 lbs Salt
		60385-0143	Injector Drain, 9000, 9100, 1.0 BLFC #1 INJ, 2.4 DLFC			19654	Label, 0.125 GPM Brine Refill Flow
		60385-0163	Injector Drain, 9000, 9100, 1.0 BLFC #1 INJ, 3.5 DLFC				
		60385-0233	Injector Drain, 9000, 9100, 1.0 BLFC #2 INJ, 2.0 DLFC				
		60385-0243	Injector Drain, 9000, 9100, 1.0 BLFC #2 INJ, 2.4 DLFC				
		60385-0253	Injector Drain, 9000, 9100, 1.0 BLFC #2 INJ, 3.0 DLFC				
		60385-0263	Injector Drain, 9000, 9100, 1.0 BLFC #2 INJ, 3.5 DLFC				
		60385-0273	Injector Drain, 9000, 9100, 1.0 BLFC #2 INJ, 4.0 DLFC				
		60385-0353	Injector Drain, 9000, 9100, 1.0 BLFC #3 INJ, 3.0 DLFC				
		60385-0373	Injector Drain, 9000, 9100, 1.0 BLFC #3 INJ, 4.0 DLFC				
		60385-0383	Injector Drain, 9000, 9100, 1.0 BLFC #3 INJ, 5.0 DLFC				
		60385-0393	Injector Drain, 9000, 9100, 1.0 BLFC #3 INJ, 7.0 DLFC				
		60385-0120	Injector Drain, 9000, 9100, Blank BLFC #1 INJ, 1.5 DLFC				
56		60022-12	BLFC, 0.125 GPM, 5000/5600/9000/9100				
		60022-25	BLFC, 0.25 GPM, 5000/5600/9000/9100				

9500 CONTROL VALVE ASSEMBLY

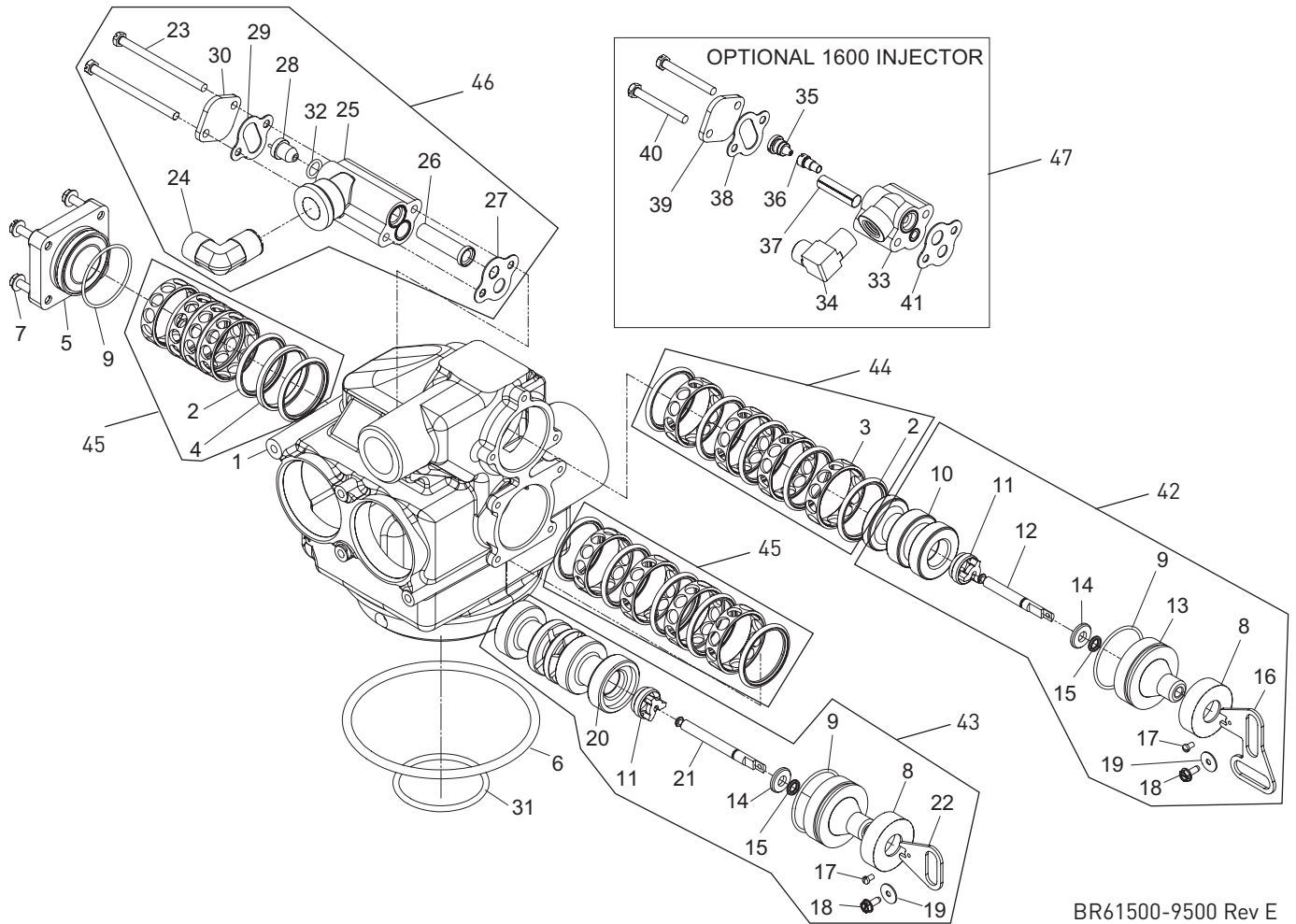

BR61500-9500 Rev E

Item No.	QTY	Part No.	Description
1	1	16919-01	Valve Body, 9500, Machining
2	16	16101	Seal, 2850, 4500
		41113	Seal, 2850, 559PE
3	12	16638	Spacer, 9500/2850, Cold & Hot Water
		16638-02	Spacer, 9500/2850, MS1050, Plastic
4	1	17092	Spacer, Disc, 9500
5	1	43458-01	End Cap, Plastic, 9500
6	1	16455	O-ring, -347
7	4	15331	Screw, Hex Washer Head
8	2	17558	Disc, Spacer, End Plug
9	3	16394	O-ring, -029
10	1	17110	Piston, 9500, Upper
11	2	14309	Retainer, Piston Rod
12	1	16957	Rod, Piston, 9500
13	2	16954	Plug, End, 9500
14	2	13008	Retainer, End Plug Seal
15	2	10209	Quad Ring, -010

Item No.	QTY	Part No.	Description
16	1	14921	Link, Piston Rod
17	2	11335	Screw, #4-40
18	2	17020	Screw, STL. Hex Washer, 6-20 x 3/8
19	2	13363	Washer, Plain, .145 ID S.S.
20	1	17111	Piston, 9500, Lower
21	1	16956	Rod, Piston, Lower, 9500
22	1	15019	Link, Piston Rod, 9000/9500, 9100
23	2	14804	Screw, Slotted Hex Head
24	1	15413	Fitting, Elbow, Male, 1/2 TX 3/8 NPT
25	1	17777-03	Body, Injector, 1700
26	1	14802-03C	Throat, Injector, #3C, Yellow
		14802-04C	Throat, Injector, #4C, Green
		14802-05C	Throat Injector, #5C, White
		14802-06C	Throat Injector, #6C, Red
27	1	14805	Gasket, Injector Body
28	1	14801-03C	Nozzle, Injector, 3C, Yellow
		14801-04C	Nozzle, Injector, 4C, Green

9500 CONTROL VALVE ASSEMBLY *CONTINUED*

Item No.	QTY	Part No.	Description	Item No.	QTY	Part No.	Description
	 14801-05CNozzle, Injector, 5C, White 60481-21Injector Assy, 1600, #1, S.S. Brass, HW	
	 14801-06CNozzle, Injector, 6C, Red 60481-22Injector Assy, 1600, #2, S.S. Brass, HW	
29 1 10229Gasket, Injector Body 60481-23Injector Assy, 1600, #3, S.S. Brass, HW	
30 1 11893Cap, Injector 60080-11Injector Assy, 1600, #1, PVC	
31 1 13577O-ring, -226 60080-12Injector Assy, 1600, #2, PVC	
32 1 13771O-ring, -012 60080-14Injector Assy, 1600, #4, PVC	
Optional (1600) Injector Part Number				Not Shown			
33 17776Body, Injector, 1600 60366-00DLFC, 1 inch F x 3/4 inch F, NPT, No Button	
34 10328Fitting, Elbow, 90 Deg. 60366-06DLFC, 1 inch F x 3/4 inch F, NPT, 0.6 GPM	
35 10913-1Nozzle, Injector, #1, Natural 60366-08DLFC, 1 inch F x 3/4 inch F, NPT, 0.8 GPM	
36 10914Throat, Injector 60366-10DLFC, 1 inch F x 3/4 inch F, NPT, 1.0 GPM	
37 10227Screen, Injector 60366-12DLFC, 1 inch F x 3/4 inch F, NPT, 1.2 GPM	
38 10229Gasket, Injector Body 60366-13DLFC, 1 inch F x 3/4 inch F, NPT, 1.3 GPM	
39 11893Cap, Injector 60366-15DLFC, 1 inch F x 3/4 inch F, NPT, 1.5 GPM	
40 10692Screw, Slot, Indented Hex Head 60366-17DLFC, 1 inch F x 3/4 inch F, NPT, 1.7 GPM	
41 14805Gasket, Injector Body 60366-20DLFC, 1 inch F x 3/4 inch F, NPT, 2.0 GPM	
42 60108Piston Assy, 9500, Upper 60366-24DLFC, 1 inch F x 3/4 inch F, NPT, 2.4 GPM	
	 60108-01Piston Assy, 9500, Upper, HW 60366-30DLFC, 1 inch F x 3/4 inch F, NPT, 3.0 GPM	
	 60108-02Piston Assy, 9500, Upper, 560CD 60366-35DLFC, 1 inch F x 3/4 inch F, NPT, 3.5 GPM	
43 60109Piston Assy, 9500, Lower 60366-40DLFC, 1 inch F x 3/4 inch F, NPT, 4.0 GPM	
	 60109-01Piston Assy, 9500, HW, Lower 60366-45DLFC, 1 inch F x 3/4 inch F, NPT, 4.5 GPM	
	 60109-02Piston Assy, 9500, Lower, 560CD 60366-50DLFC, 1 inch F x 3/4 inch F, NPT, 5.0 GPM	
44 60134Seal & Spacer Kit, 9500, Upper, Hot & Cold 60366-60DLFC, 1 inch F x 3/4 inch F, NPT, 6.0 GPM	
	 60134-20Seal & Spacer Kit, 9500, Upper, Plastic Spacers, Chemical Resistent Seals 60366-70DLFC, 1 inch F x 3/4 inch F, NPT, 7.0 GPM	
45 60133-01Seal & Spacer Kit, 9500, Lower, Hot & Cold 60708-00DLFC, 1 inch F x 3/4 inch F, NPT, No Button	
	 60133-20Seal & Spacer Kit, 9500, Lower, Plastic Spacers, Chemical Resistent Seals 60708-8.0DLFC, 1 inch F x 3/4 inch F, NPT, 8.0 GPM	
46 60381-03Injector Assy, 1700, #3C 60708-9.0DLFC, 1 inch F x 3/4 inch F, NPT, 9.0 GPM	
	 60381-04Injector Assy, 1700, #4C 60708-10DLFC, 1 inch F x 3/4 inch F, NPT, 10.0 GPM	
	 60381-05Injector Assy, 1700, #5C				
	 60381-06Injector Assy, 1700, #6C				
47 60480-00Injector Assy, 1600, #0, Plastic				
	 60480-01Injector Assy, 1600, #1, Plastic				
	 60480-02Injector Assy, 1600, #2, Plastic				
	 60480-03Injector Assy, 1600, #3, Plastic				
	 60480-04Injector Assy, 1600, #4, Plastic				

9500 CONTROL VALVE ASSEMBLY *CONTINUED*

Item No.	QTY	Part No.	Description	Item No.	QTY	Part No.	Description
.....		60708-12.....	DLFC, 1 inch F x 3/4 inch F, NPT, 12.0 GPM		60721-70.....	DLFC, 1 inch F x 1 inch F, NPTF, 7.0 GPM
.....		60708-15.....	DLFC, 1 inch F x 3/4 inch F, NPT, 15.0 GPM		60702-00.....	DLFC, 1 inch M x 1 inch F, NPT, Brass, No Button
.....		60721-00.....	DLFC, 1 inch F x 1 inch F, NPT, No Button		60702-8.0.....	DLFC, 1 inch M x 1 inch F, NPT, 8.0 GPM
.....		60721-06.....	DLFC, 1 inch F x 1 inch F, NPT, 0.06 GPM		60702-9.0.....	DLFC, 1 inch M x 1 inch F, NPT, 9.0 GPM
.....		60721-08.....	DLFC, 1 inch F x 1 inch F, NPT, 0.08 GPM		60702-10.....	DLFC, 1 inch M x 1 inch F, NPT, 10 GPM
.....		60721-10.....	DLFC, 1 inch F x 1 inch F, NPT, 1.0 GPM		60702-12.....	DLFC, 1 inch M x 1 inch F, NPT, 12 GPM
.....		60721-12.....	DLFC, 1 inch F x 1 inch F, NPT, 1.2 GPM		60702-15.....	DLFC, 1 inch M x 1 inch F, NPT, 15 GPM
.....		60721-13.....	DLFC, 1 inch F x 1 inch F, NPT, 1.3 GPM				
.....		60721-15.....	DLFC, 1 inch F x 1 inch F, NPT, 1.5 GPM				
.....		60721-00.....	DLFC, 1 inch F x 1 inch F, NPTF, No Button				
.....		60721-17.....	DLFC, 1 inch F x 1 inch F, NPTF, 1.7 GPM				
.....		60721-20.....	DLFC, 1 inch F x 1 inch F, NPTF, 2.0 GPM				
.....		60721-24.....	DLFC, 1 inch F x 1 inch F, NPTF, 2.4 GPM				
.....		60721-30.....	DLFC, 1 inch F x 1 inch F, NPTF, 3.0 GPM				
.....		60721-35.....	DLFC, 1 inch F x 1 inch F, NPTF, 3.5 GPM				
.....		60721-40.....	DLFC, 1 inch F x 1 inch F, NPTF, 4.0 GPM				
.....		60721-45.....	DLFC, 1 inch F x 1 inch F, NPTF, 4.5 GPM				
.....		60721-50.....	DLFC, 1 inch F x 1 inch F, NPTF, 5.0 GPM				
.....		60721-60.....	DLFC, 1 inch F x 1 inch F, NPTF, 6.0 GPM				

1600 BRINE VALVE SYSTEM (FOR 9500)

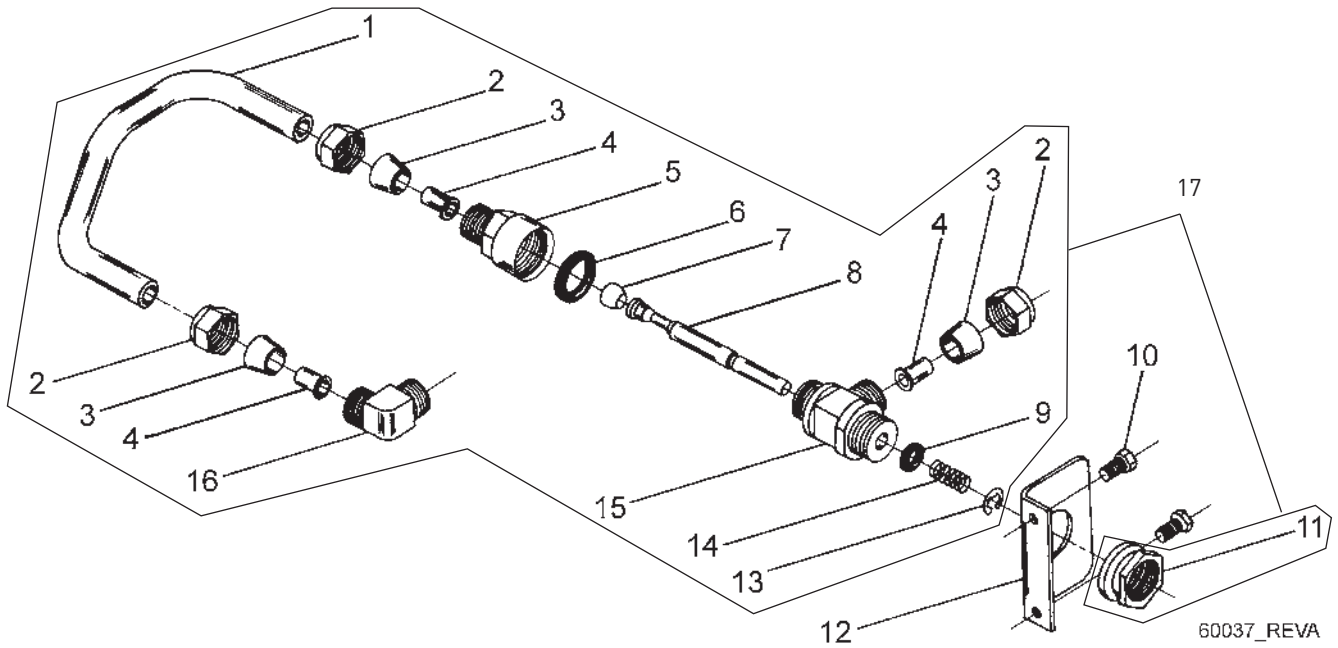

60037_REVA

Item No.	QTY	Part No.	Description
1	1	16960	Tube, Brine Valve
	1	16960	Tube, Brine Valve, HW
2	1	10329	Fitting, Tube, 3/8 Nut, Brass
		18698	Nut, 3/8-inch Tube, W/ Sleeve, HW
3	1	10330	Fitting, Sleeve, 3/8 Celcon
4	1	10332	Fitting, Insert, 3/8
5	1	12747	Fitting, Flow Control
		60020-25	BLFC, 0.25 GPM, 1600
		60020-50	BLFC, 0.50 GPM, 1600
		60020-100	BLFC, 1.0 GPM, 1600
6	1	12550-01	Quad Ring, -009, 560CD
7	1	12626-01	Seat, Brine Valve, 560CD
8	1	16958	Brine Valve Stem, 1600 Coated
9	1	11982-01	O-ring, -016, 560CD
10	3	15137	Screw, Hex Washer Mach, 10-24 x 3/8
11	3	10269	Nut, Jam, 3/84 - 16
12	3	16922	Bracket, Brine Valve Mounting
13	1	10250	Ring, Retaining
14	1	10249	Spring, Brine Valve
15	1	12748-01	Brine Valve Body, 1600
16	2	10328	Fitting, Elbow, 90 Deg.
17		60037-610	Brine Valve Assy. 9500/1600 0.25 GPM
		60037-620	Brine Valve Assy. 9500/1600 0.50 GPM
		60037-630	Brine Valve Assy. 9500/1600 1.0 GPM
		60037HW	Brine Valve Assy. 9500/1600 Hot Water

1700 BRINE VALVE SYSTEM (FOR 9500)

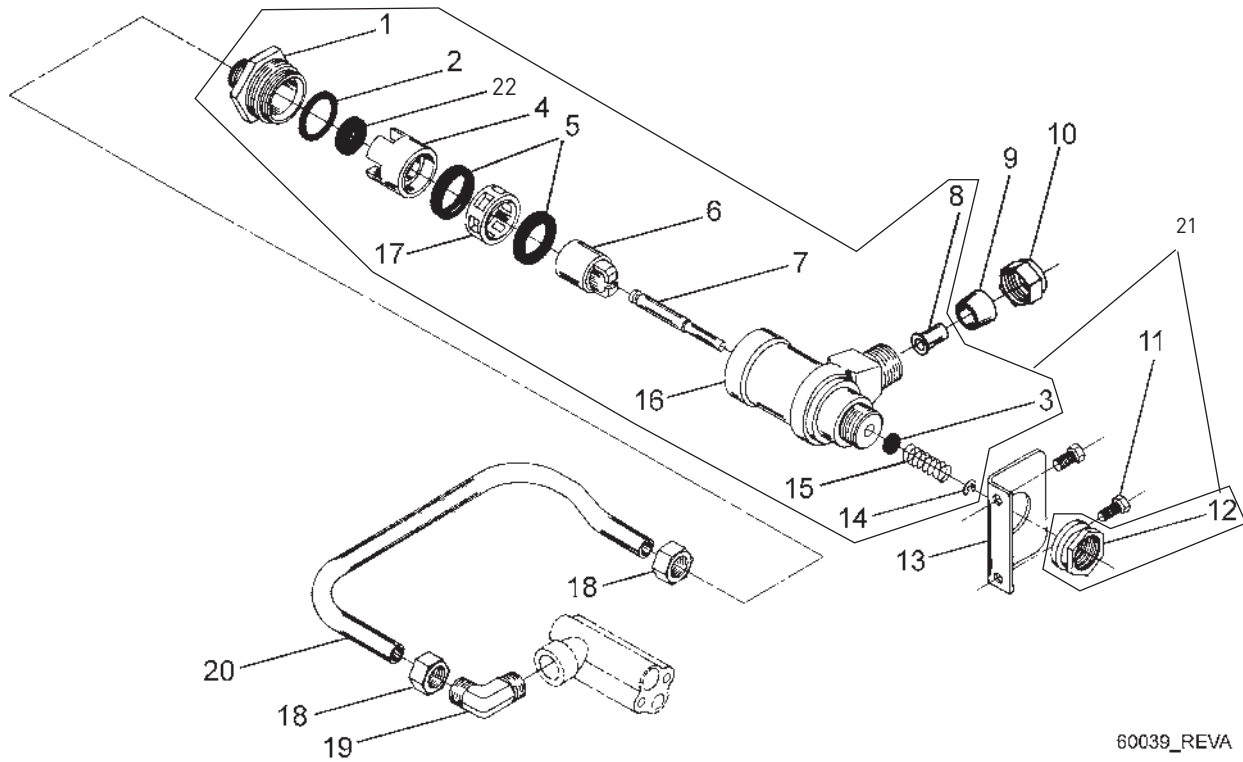

60039_REVA

Item No.	QTY	Part No.	Description	Item No.	QTY	Part No.	Description
1	1	14792	Plug, End, Brine Valve	21	1	60039-10	Brine Valve Assy. 9500/1700 1.0 GPM
2	1	13201	Quad Ring, -020			60039-12	Brine Valve Assy. 9500/1700 1.2 GPM
		13201-01	Quad Ring, -20, 560CD			60039-15	Brine Valve Assy. 9500/1700 1.5 GPM
3	1	12550	Quad Ring, -009			60039-20	Brine Valve Assy. 9500/1700 2.0 GPM
		12550-01	Quad Ring, -009, 560CD			60039-24	Brine Valve Assy. 9500/1700 2.4 GPM
4	1	14785-01	Retainer, Flow Control			60039-30	Brine Valve Assy. 9500/1700 3.0 GPM
5	2	14811	O-ring, -210, 560CD, Brine			60039-50	Brine Valve Assy. 9500/1700 5.0 GPM
6	1	14795	Piston, Brine Valve			60039-00	Brine Valve Assy. 9500/1700 Blank
7	1	16929	Brine Valve Stem, Coated	22	1	12097	Washer, Flow, 1.0 GPM
8	1	15415	Fitting, Insert, 1/2-inch Tube			12085	Washer, Flow, 1.2 GPM
9	1	16124	Fitting, Sleeve, Delrin			19150	Washer, Flow, 1.3 GPM
10	1	16123	Nut, Brass			12086	Washer, Flow, 1.5 GPM
11	1	15137	Screw, Hex Washer Mach, 10-24 x 3/8			19149	Washer, Flow, 1.7 GPM
12	1	10269	Nut, Jam, 3/4 - 16			12087	Washer, Flow, 2.0 GPM
13	1	16922	Bracket, Brine Valve Mounting			12088	Washer, Flow, 2.4 GPM
14	2	10250	Ring, Retaining			12089	Washer, Flow, 3.0 GPM
15	1	15310	Spring, Brine Valve			12090	Washer, Flow, 3.5 GPM
16	2	14790	Brine Valve Body			12091	Washer, Flow, 4.0 GPM
17	1	14798	Spacer, 1700, Brine			19147	Washer, Flow, 4.5 GPM
18	1	15414	Nut, 2900, w/Sleeve			12092	Washer, Flow, 5.0 GPM
19	1	15413	Fitting, Elbow, Male, 1/2T x 3/8 NPT			17814	Washer, Flow, 6.0 GPM
20	1	16959	Tube, Brine 9500/1710, 10.6 inches			12408	Washer, Flow, 7.0 GPM
		16959-01	Tube, Brine Valve 9500/1710, CPVC, Hot Water				

1710 BRINE VALVE SYSTEM (FOR 9500)

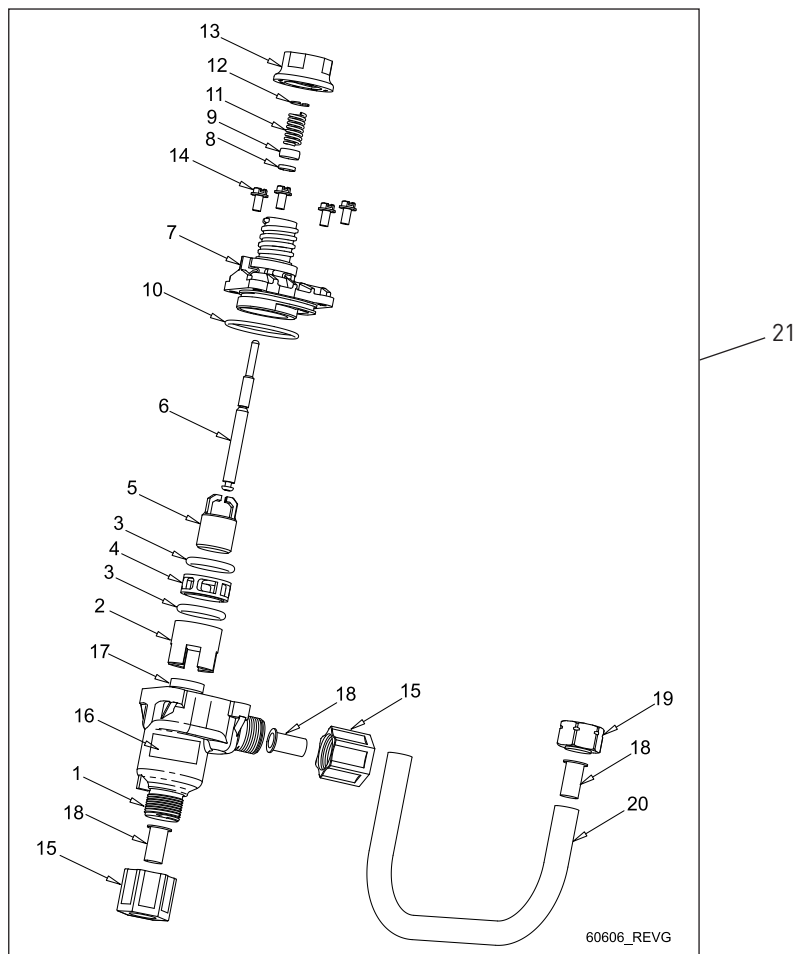

Item No.	QTY	Part No.	Description	Item No.	QTY	Part No.	Description
1	1	41202	Brine Valve, 1700, Plastic, Top	17	1		Washer, Flow (Specify GPM)
2	1	14785-01	Retainer, Flow Control	18	3	15415	Fitting, Insert, 1/2-inch, Tube
3	2	14811	O-ring, -210, 560CD, Brine	19	1	15414	Nut, 2900, w/Sleeve
4	1	14798	Spacer, 1700, Brine	20	1	16959	Tube, Brine 9500/1700, 10.6 inches
5	1	14795	Piston, Brine Valve	21		60606-10	Brine Valve Assy. 9500/1710 1.0 GPM
6	1	41429	Stem, Brine, 1710, Plastic, 9500			60606-12	Brine Valve Assy. 9500/1710 1.2 GPM
7	1	41201	Brine Valve, 1700, Plastic, Bottm			60606-15	Brine Valve Assy. 9500/1710 1.5 GPM
8	1	12550	Ring, Quad, -009			60606-20	Brine Valve Assy. 9500/1710 2.0 GPM
9	1	17908	Sleeve, Brine Valve Stem			60606-24	Brine Valve Assy. 9500/1710 2.4 GPM
10	1	41547	O-ring, 2mm x 35mm			60606-30	Brine Valve Assy. 9500/1710 3.0 GPM
11	1	15310	Spring, Brine Valve			60606-40	Brine Valve Assy. 9500/1710 4.0 GPM
12	1	10250	Ring, Retaining			60606-50	Brine Valve Assy. 9500/1710 5.0 GPM
13	1	17906-01	Guide, Brine Valve Stem			60606-00	Brine Valve Assy. 9500/1710 Blank
14	4	14202-01	Screw, Hex Washer, Mach, 8-32 x 5/16				
15	2	41056	Nut Assy, 1/2-inch Plastic				
16	1	41493-XX	Label, BLFC, 1710 (Specify GPM)				

3/4-INCH METER ASSEMBLY

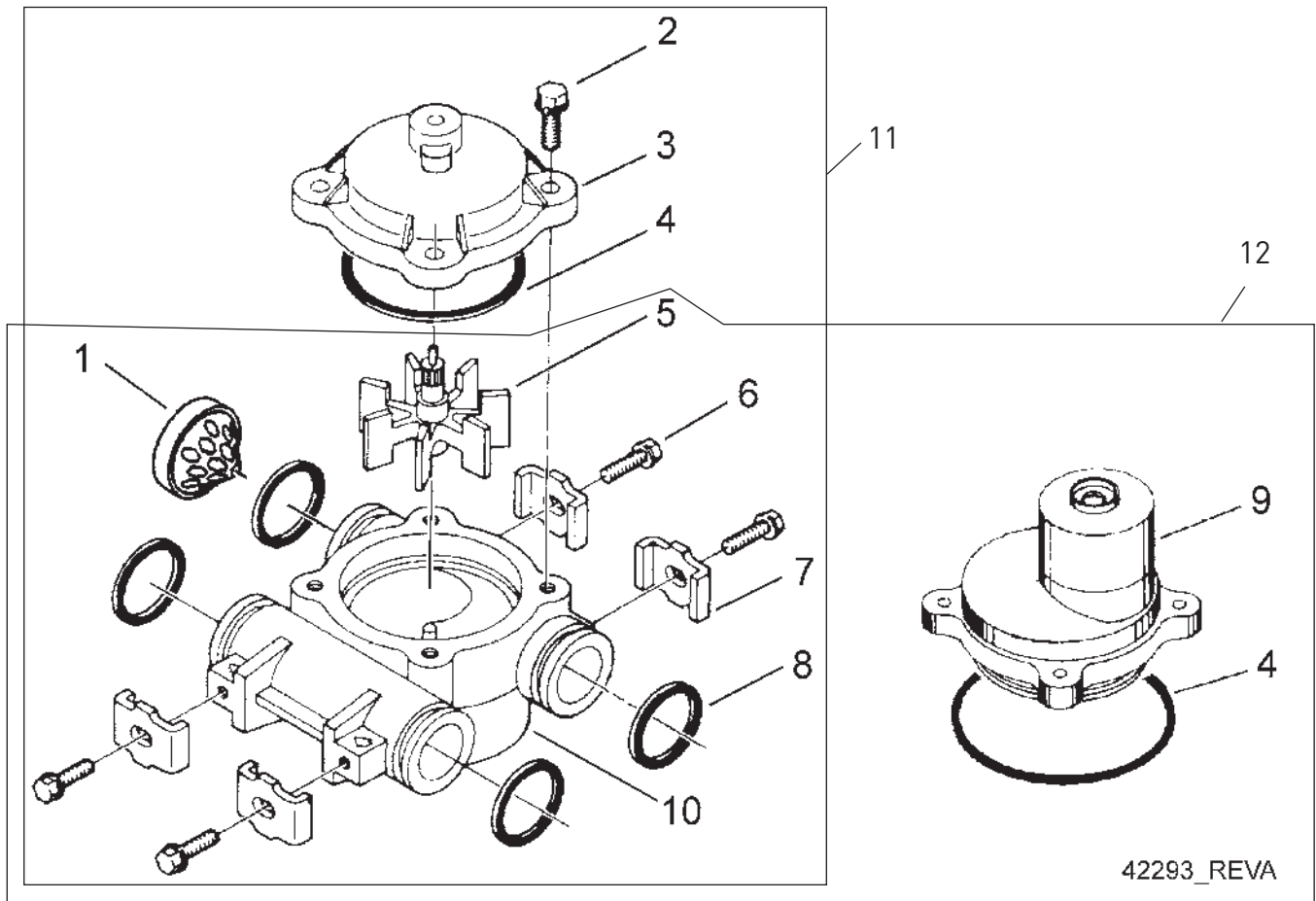

42293_REVA

Item No.	QTY	Part No.	Description
1	1	14613	Flow Straightener
2	4	12473	Screw, Hex Washer, 10-24 x 5/8
3	1	14038	Meter Cap Assy, STD, Plastic
4	1	13847	O-ring, -137, Std/560CD, Meter
5	1	13509	Impeller, Meter
6	4	13314	Screw, Slot Ind Hex, 8-18 x .60
7	4	13255	Clip, Mounting
8	4	13305	O-ring, -119
9	1	15150	Meter Cap Assy, EXT, Plastic Paddle
10	1	13821	Body, Meter, 5600
11	1	60086	Meter Assy, 3/4-inch Dual Port, Slip, STD, Plastic, Paddlewheel, w/Clips
12	1	60087	Meter Assy, 3/4-inch Dual Port, Slip, EXT, Plastic, Paddlewheel, w/Clips

1-INCH METER ASSEMBLY

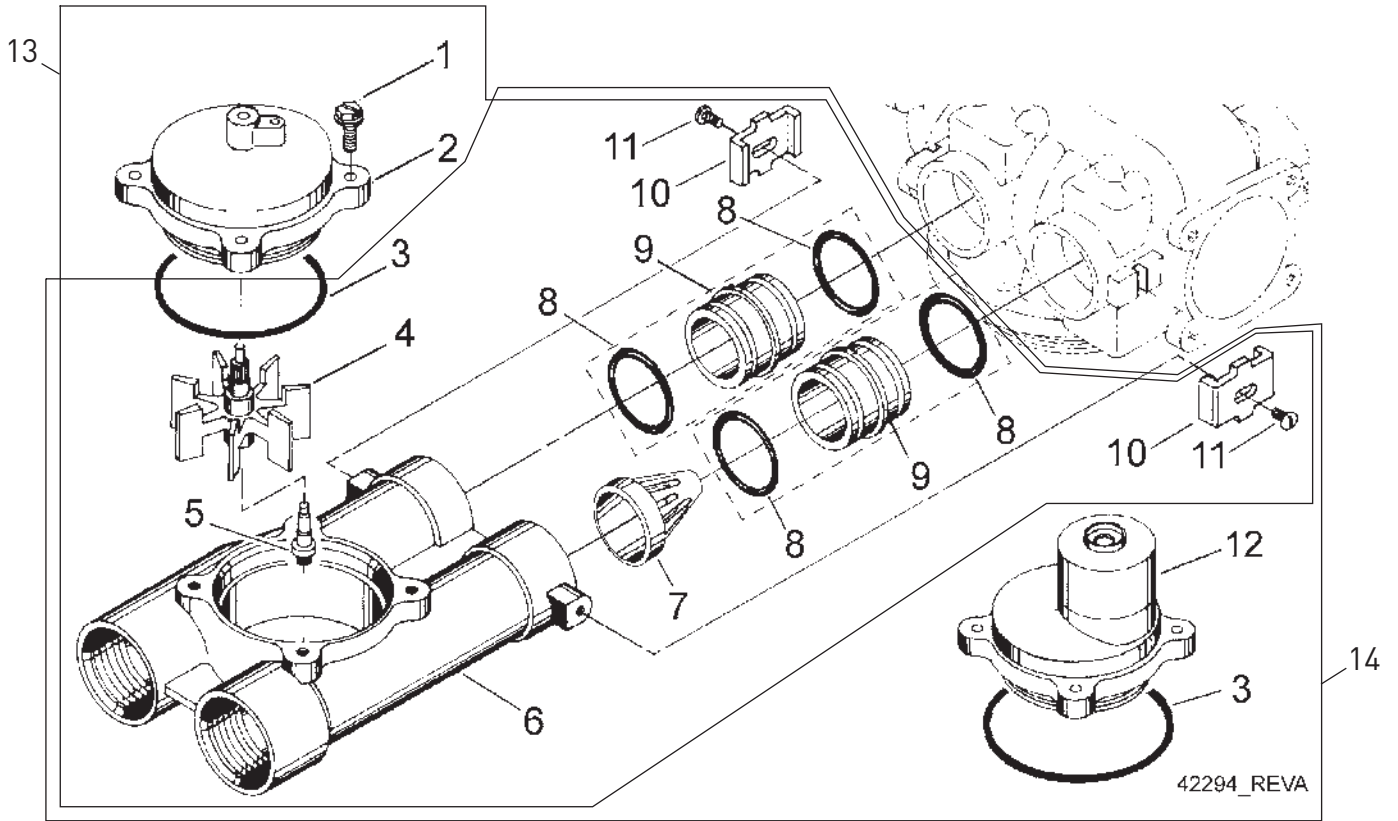

1-INCH METER ASSEMBLY

Item No.	QTY	Part No.	Description	Item No.	QTY	Part No.	Description
1	4	12112	Screw, Hex Hd Mach 10-24 x 1/2	60389-001NP	Meter Assy, 1-inch Dual Port, NPT, STD, BRS BDY, 560CD, PDL, W/CLPS
2	1	15218	Meter Cap Assy, Brass, Standard	60389NP	Meter Assy, 1-inch Dual Port, NPT, STD, BRS BDY, NP, PDL, W/CLPS
		14038	Meter Cap Assy, Standard	60612	Meter Assy, 1-inch Dual Port, NPT, STD, BRS, HW, PDL
3	1	13847	O-ring, -137, STD/560CD, Meter	60612NP	Meter Assy, 1-inch Dual Port, NPT, STD, BRS, HW, NP, PDL
4	1	13509	Impeller, Meter	61575	Meter Assy, 1-inch Dual Port, NPT, STD, BRS BDY, PDL, W/O CLP & SCW
		13509-01	Impeller, Celcon	60389-20	Meter Assy, 1-inch Dual Port, BSP/Metric, STD, BRS BDY, PDL, W/CLPS
5	1	13882	Post, Meter Impeller	60390-20	Meter Assy, 1-inch Dual Port, BSP/Metric, EXT, BRS BDY, PDL, W/CLPS
6	1	15043	Body, Meter, 9000 1-inch	60632-20	Meter Assy, 1-inch Dual Port, BSP/Metric, EXT, BRS, HW, PDL
7	1	14960	Flow Straightener, 1-inch	60612-20	Meter Assy, 1-inch Dual Port, BSP/Metric, STD, BRS, HW, PDL
8	4	13305	O-ring, -119	60389	Meter Assy, 1-inch Dual Port, NPT, STD, BRS BDY, PDL, W/CLPS
9	2	15078	Adapter, 1-inch Coupling	60389-001	Meter Assy, 1-inch Dual Port, NPT, EXT, BRS BDY, 560CD, PDL, W/CLPS
10	2	13255	Clip, Mounting	60390NP	Meter Assy, 1-inch Dual Port, NPT, EXT, BRS BDY, NP, PDL, W/CLPS
11	2	14202-01	Screw, Hex Washer Mach, 8-32 x 5/16	60632	Meter Assy, 1-inch Dual Port, NPT, EXT, BRS, HW, PDL
12	1	15150	Meter Cap Assy, Ext, Plastic Paddle	60632NP	Meter Assy, 1-inch Dual Port, NPT, EXT, BRS, HW, NP, PDL
		15237	Meter Cap Assy, Ext, Brass Paddle	60389	Meter Assy, 1-inch Dual Port, NPT, STD, BRS BDY, PDL, W/CLPS
13		60390	Meter Assy, 1-inch Dual Port, NPT, EXT, BRS BDY, PDL, W/CLPS	60389-001	Meter Assy, 1-inch Dual Port, NPT, STD, BRS BDY, 560CD, PDL, W/CLPS
		60390-001	Meter Assy, 1-inch Dual Port, NPT, EXT, BRS BDY, 560CD, PDL, W/CLPS				
		60390NP	Meter Assy, 1-inch Dual Port, NPT, EXT, BRS BDY, NP, PDL, W/CLPS				
		60632	Meter Assy, 1-inch Dual Port, NPT, EXT, BRS, HW, PDL				
		60632NP	Meter Assy, 1-inch Dual Port, NPT, EXT, BRS, HW, NP, PDL				
		60389	Meter Assy, 1-inch Dual Port, NPT, STD, BRS BDY, PDL, W/CLPS				
		60389-001	Meter Assy, 1-inch Dual Port, NPT, STD, BRS BDY, 560CD, PDL, W/CLPS				

1-1/2 INCH BRASS METER ASSEMBLY

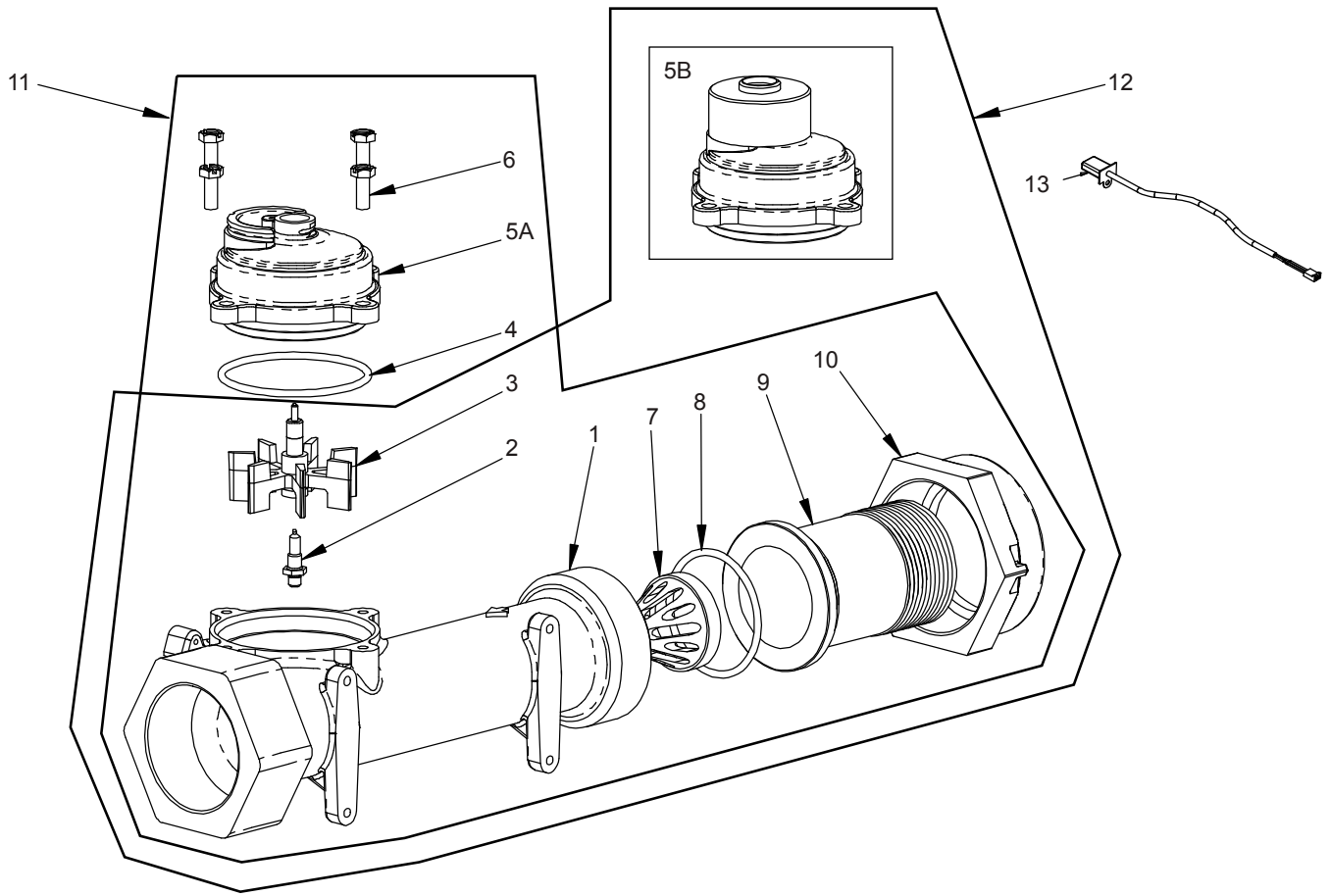

Item No.	QTY	Part No.	Description
1	1	17569	Body, Meter, 2850/9500
2	1	13882	Post, Meter Impeller
3	1	13509	Impeller, Meter
	1	13509-01	Impeller, Celcon, Hot Water
4	1	13847	O-Ring, -137, Std/560CD, Meter
5A	1	14038	Meter Cap Assy, STD Range, Plastic
5B	1	15150	Meter Cap Assy, Ext Range, Plastic
6	4	12112	Screw, Hex Hd Mach, 10-24 x 1/2 18-8 Stainless Steel
7	1	17542	Flow Straightener, 1-1/2 inches
8	1	12733	O-Ring, -132
9	1	17544	Fitting, 1-1/2 inch Quick Connector
10	1	17543	Nut, 1-1/2-inch, Q/C
11		60610-01	Meter Assy, 1-1/2 inch, NPT, STD, Brass, Paddlewheel
		60610-21	Meter Assy, 1-1/2 inch, BSP, STD, Brass, Paddlewheel

Item No.	QTY	Part No.	Description
12		60610-02	Meter Assy, 1-1/2 inch, NPT, STD, Brass Paddlewheel
		60610-22	Meter Assy, 1-1/2 inch, BSP, EXT, Brass Paddlewheel
13	1	19121	Meter Cable Assembly,
		19121-08	Meter Cable Assembly, 35 inch long with connector
		19121-09	Meter Cable Assembly, 100 inch long with connector
		19121-10	Meter Cable Assembly 304 inch long with connector

Not Shown

1	17790	Sleeve, Meter, 1-1/2 inch x 1 inch
1	15218	Meter Cap Assy, STD Range, Brass, Hot Water
1	15237	Meter Cap Assy, EXT Range, Brass, Hot Water
		Sleeve, Meter, 1.5 inch x 1 inch

1-1/2 INCH STAINLESS STEEL METER ASSEMBLY

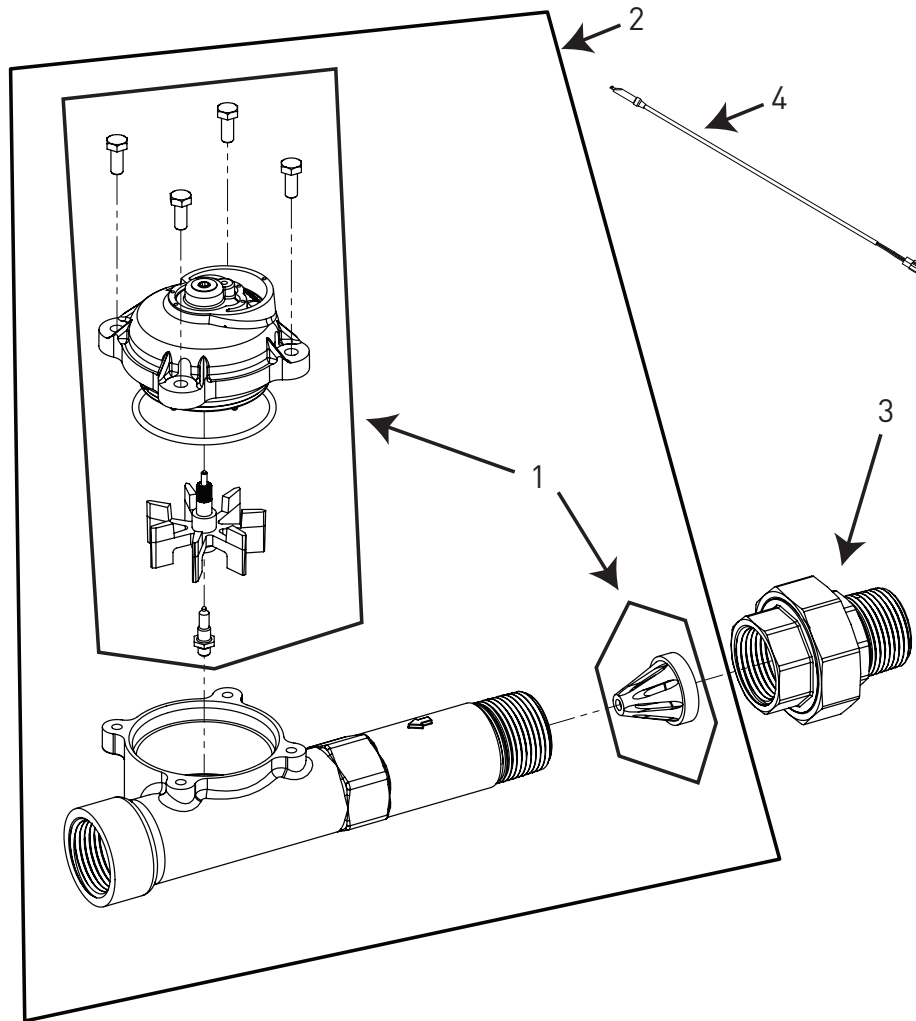

⚠ IMPORTANT: For valves equipped with electromechanical timers and stainless steel meters, refer to the Meter Dome and Union Orientation section.

Item No.	QTY	Part No.	Description
1	1	62049-01	Service Kit, 1 inch & 1-1/2 inch Meter, Standard Range
1	1	62049-02	Service Kit, 1 inch & 1-1/2 inch Meter, Extended Range
2	1	61933-10	Meter Assy, 1-1/2 inch, Inline, Stainless Steel, NPT, Standard Range
1	1	61933-11	Meter Assy, 1-1/2 inch, Inline, Stainless Steel, NPT, Extended Range
1	1	61933-20	Meter Assy, 1-1/2 inch, Inline, Stainless Steel, BSP, Standard Range
1	1	61933-21	Meter Assy, 1-1/2 inch, Inline, Stainless Steel, BSP, Extended Range

Item No.	QTY	Part No.	Description
3	1	44024	Union, 1-1/2 inch, NPT (Optional on models with electronic controls)
1	1	44025	Union, 1-1/2 inch, BSP (Optional on models with electronic controls)
4	1	19121	Meter Cable Assembly, 35 inch long with connector
		19121-08	Meter Cable Assembly, 35 inch long with connector
		19121-09	Meter Cable Assembly, 100 inch long with connector
		19121-10	Meter Cable Assembly, 304 inch long with connector

Not Shown (optional)

1	1	44061	Meter Sleeve, 1-1/2 inch to 1 inch (optional)
---	---	-------	---

9000 SECOND TANK ASSEMBLY

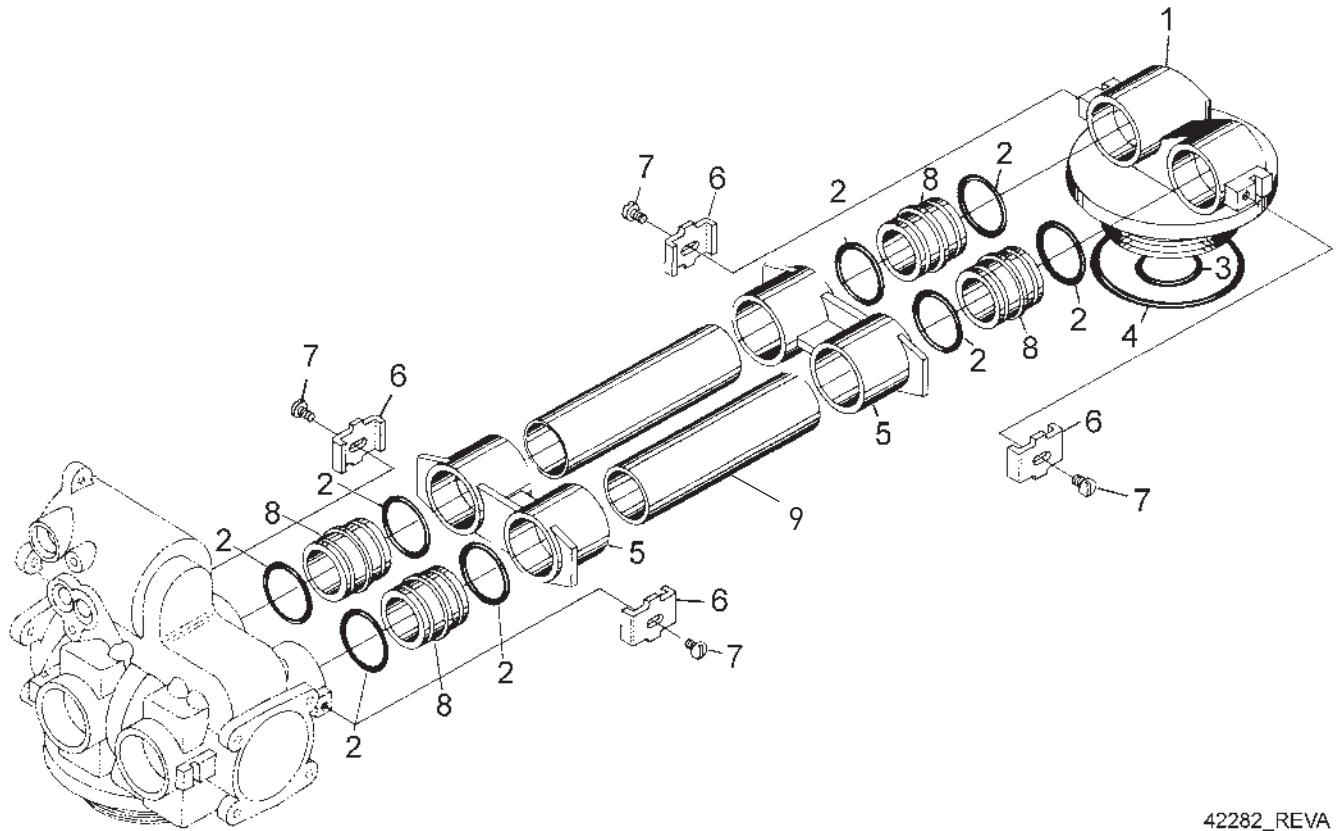

42282_REVA

Item No.	QTY	Part No.	Description
1	1	14864-01	Adapter, 9000, 2nd Tank, Machd w/O-rings
2	8	13305	O-ring, -119
3	1	11710	O-ring, -215
4	1	12281	O-ring, -338
5	2	13708-40	Yoke, 1-inch Sweat
	1	15823-XX	Yoke Assy. Specify Tank Size
6	4	13255	Clip, Mounting
7	4	14202-01	Screw, Hex Washer Mach, 8-32 x 5/16
8	4	15078	Adapter, 1-inch Coupling
9		15823-06	9000 Tube Assy, 6-inch Dia. Tank Only (Overall Length 7.25)
		15823-06NP	9000 Tube Assy, 6-inch Dia. Tank Only (Overall Length 7.25)
		15823-12	9000 Tube Assy, 6-inch to 12-inch Dia. Tank (Overall Length 9.75)

Item No.	QTY	Part No.	Description
		15823-12NP	9000 Tube Assy, 6-inch to 12-inch Dia. Tank (Overall Length 9.75)
		15823-14	9000 Tube Assy, 14-inch Dia. Tank (Overall Length 11.75)
		15823-14NP	9000 Tube Assy, 14-inch Dia. Tank (Overall Length 11.75)
		15823-16	9000 Tube Assy, 16-inch Dia. Tank (Overall Length 13.75)
		15823-16NP	9000 Tube Assy, 16-inch Dia. Tank (Overall Length 13.75)

9100 SECOND TANK ASSEMBLY

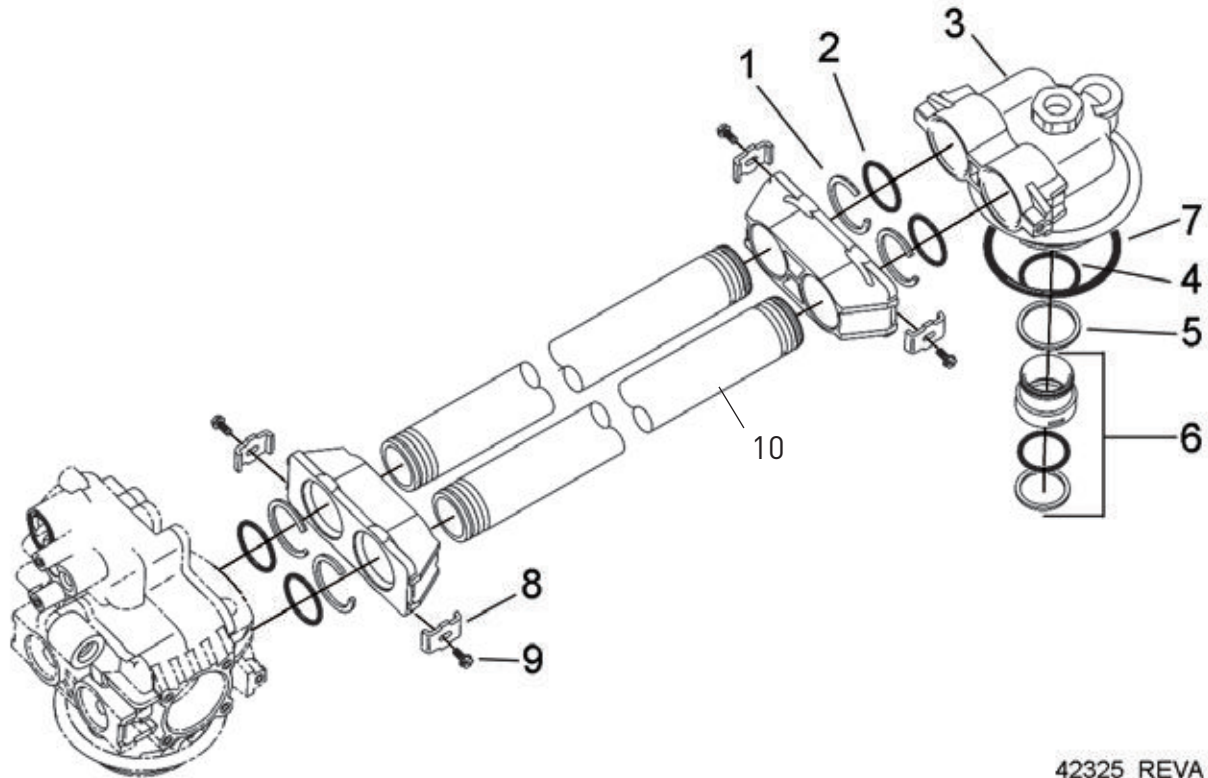

42325_REVA

Item No.	QTY	Part No.	Description
1	4	40678	Ring, 9100, Yoke Retainer
2	4	13287	O-ring, -123
3	1	14865	Adapter Assy, 2nd Tank, 9100
4	1	19054	O-ring, -124
5	1	40538	Retainer, 32mm, O-ring Dist, 7000
6	1	61419	Kit, 1.05-inch Distributor, Adapter
7	1	18303	O-ring, -336
8	4	13255	Clip, Mounting
9	4	14202-01	Screw, Hex Washer Mach, 8-32 x 5/16
10		60425-9	Tube Assy, 9100 8-9-inch Tank
		60425-12	Tube Assy, 9100 6-12-inch Tank
		60425-16	Tube Assy, 9100 13-16-inch Tank

9500 SECOND TANK ASSEMBLY

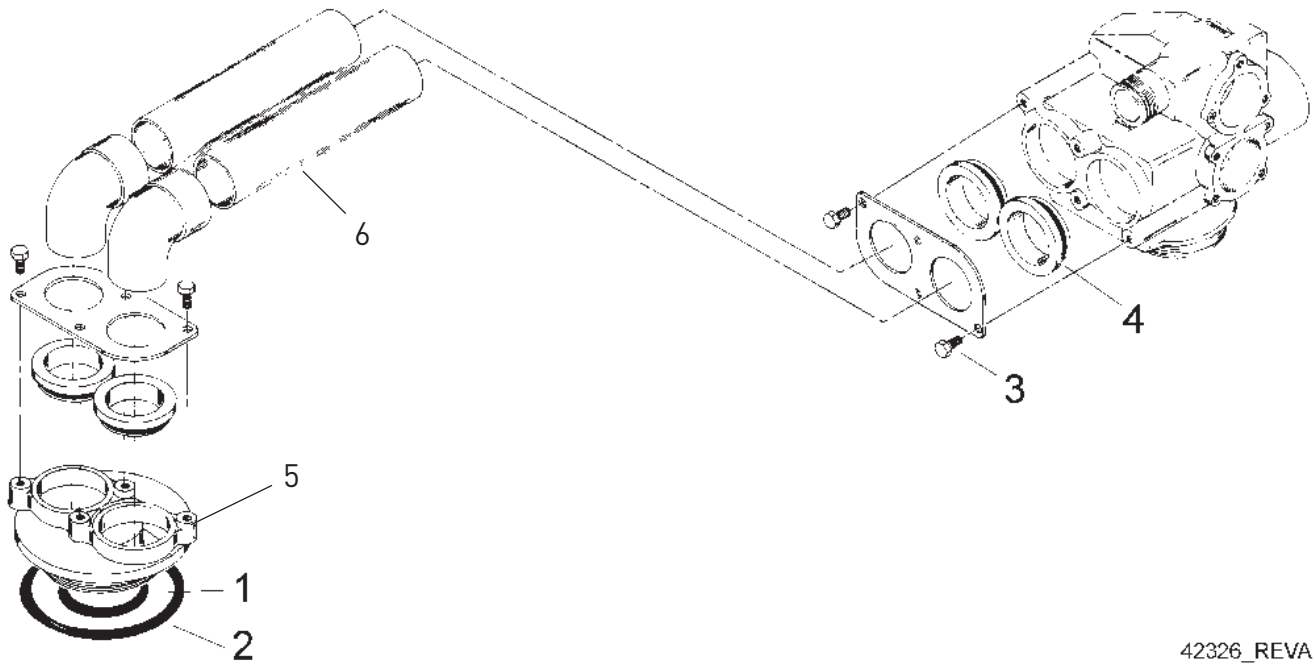

42326_REVA

Item No.	QTY	Part No.	Description
1	1	13577	O-ring, -226
2	1	16455	O-ring, -347
3	8	10231	Screw, Slot Hex, 1/4 - 20 x 1/2
4	4	17224	O-ring, -224
5	1	16916-01	Adapter, 9500, 2nd Tank, NPT
		16916-21	Adapter, 9500, 2nd Tank, Metric
		16916-01NP	Adapter, 9500, 2nd Tank, NPT, Nickel Plated
6		17465-16	Tube Assy, 2nd Tank, 16-inch 9500
		17465-16NP	Tube Assy, 2nd Tank, 16-inch 9500 Nickel Plated
		17465-20	Tube Assy, 2nd Tank, 20-inch 9500
		17465-24	Tube Assy, 2nd Tank, 24-inch 9500
		17465-24NP	Tube Assy, 2nd Tank, 24-inch 9500 Nickel Plated

2300 SAFETY BRINE VALVE

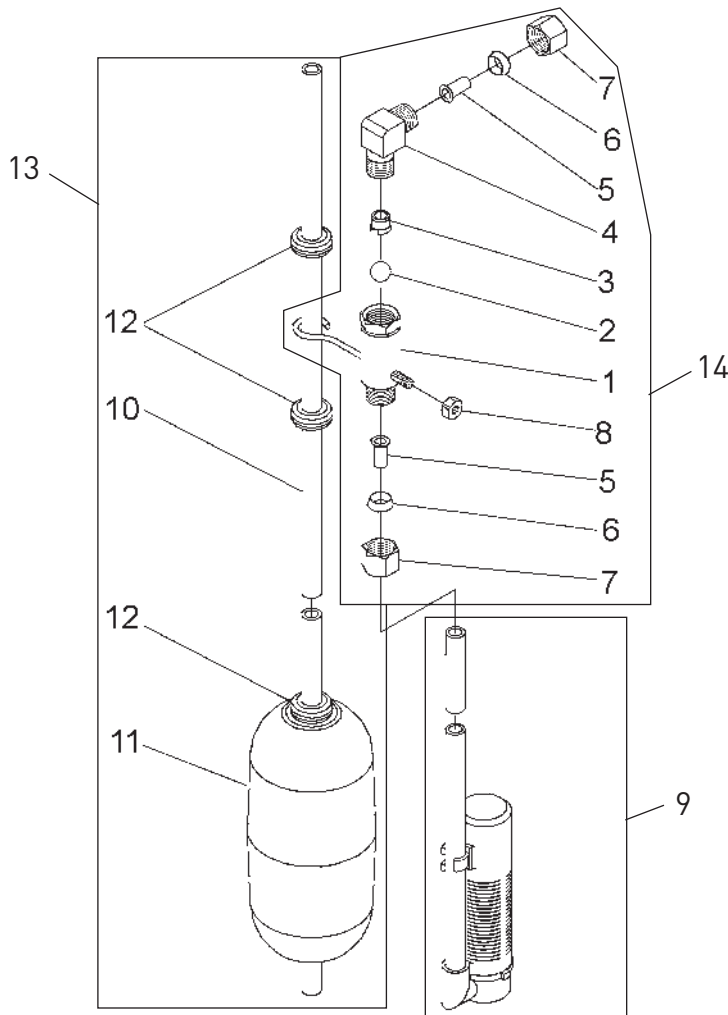

60027 Rev D

Item No.	QTY	Part No.	Description	Item No.	QTY	Part No.	Description
1	1	60027-00	Safety Brine Valve, 2300, Less Elbow	1	60002-34	Air Check, #500, 34 inches Long
2	1	10138	Ball, 3/8-inch, Brass	1	60002-36	Air Check, #500, 36 inches Long
3	1	11566	Ball Stop, Slow Fill	1	60002-48	Air Check, #500, 48 inches Long
4	1	10328	Fitting, Elbow, 90 Deg. 1/4 NPT x 3/8 Tube	1	60002-26.25	Air Check, #500, 26.25 inches Long
5	1	10332	Fitting, Insert, 3/8	1	60002-33.25	Air Check, #500, 33.25 inches Long
6	1	10330	Fitting, Sleeve, 3/8 Celcon	10	1	10149	Rod, Float, 30 inches
7	1	10329	Fitting, Tube, 3/8 Nut, Brass	11	1	10700	Float Assy, White
8	1	10186	Nut, Hex, 10-32	12	3	10150	Grommet, .30 Dia
9	1	60002-10	Air Check, #500, American Hydro	13	1	60028-30	Float Assy, 2300, 30 inches White
		60002-11.38	Air Check, #500, 11.38 inches Long	14	1	60027-FFA	Safety Brine Valve, 2300, Fitting Facing Arm
		60002-24	Air Check, #500, 24 inches Long	1	1	60027-FFS	Safety Brine Valve, 2300 Fitting Facing Stud
		60002-27	Air Check, #500, 27 inches Long				
		60002-32	Air Check, #500, 32 inches Long				

2310 SAFETY BRINE VALVE

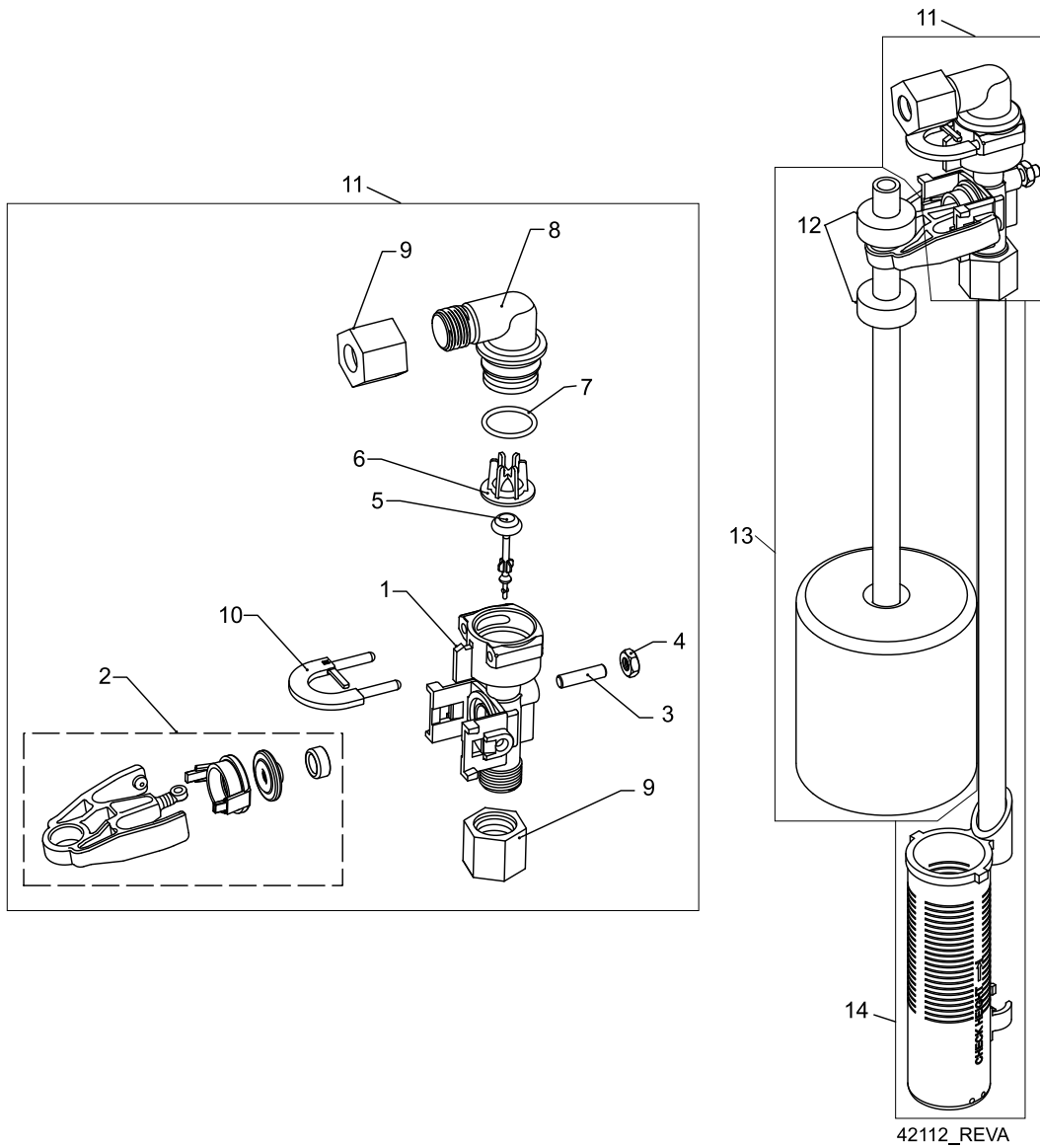

2310 SAFETY BRINE VALVE

Item No.	QTY	Part No.	Description
1	1	19645	Body, Safety Brine Valve, 2310
2	1	19803	Safety Brine Valve Assy
3	1	19804	Screw, Sckt Hd, Set, 10-24 x .75
4	1	19805	Nut, Hex, 10-24, Nylon Black
5	1	19652-01	Poppet Assy, SBV w/O-ring
6	1	19649	Flow Dispenser
7	1	11183	O-ring, -017
8	1	19647	Elbow, Safety Brine Valve
9	2	19625	Nut Assy, 3/8-inch Plastic
10	1	18312	Retainer, Drain
11	1	60014	Safety Brine Valve Assy, 2310
12	2	10150	Grommet, .30 Dia
13	1	60068-8.06	Float Assy, 2310, w/8.06-inch Rod
		60068-10.5	Float Assy, 2310, w/10.5-inch Rod
		60068-11.5	Float Assy, 2310, w/11.5-inch Rod
		60068-20	Float Assy, 2310, w/20-inch Rod
		60068-30	Float Assy, 2310, w/30-inch Rod

Item No.	QTY	Part No.	Description
14	1	60002-10	Air Check, #500, American Hydro
		60002-11.38	Air Check, #500, 11.38 inches Long
		60002-24	Air Check, #500, 24 inches Long
		60002-27	Air Check, #500, 27 inches Long
		60002-32	Air Check, #500, 32 inches Long
		60002-34	Air Check, #500, 34 inches Long
		60002-36	Air Check, #500, 36 inches Long
		60002-48	Air Check, #500, 48 inches Long
		60002-26.25	Air Check, #500, 26.25 inches Long
		60002-33.25	Air Check, #500, 33.25 inches Long

2350 SAFETY BRINE VALVE

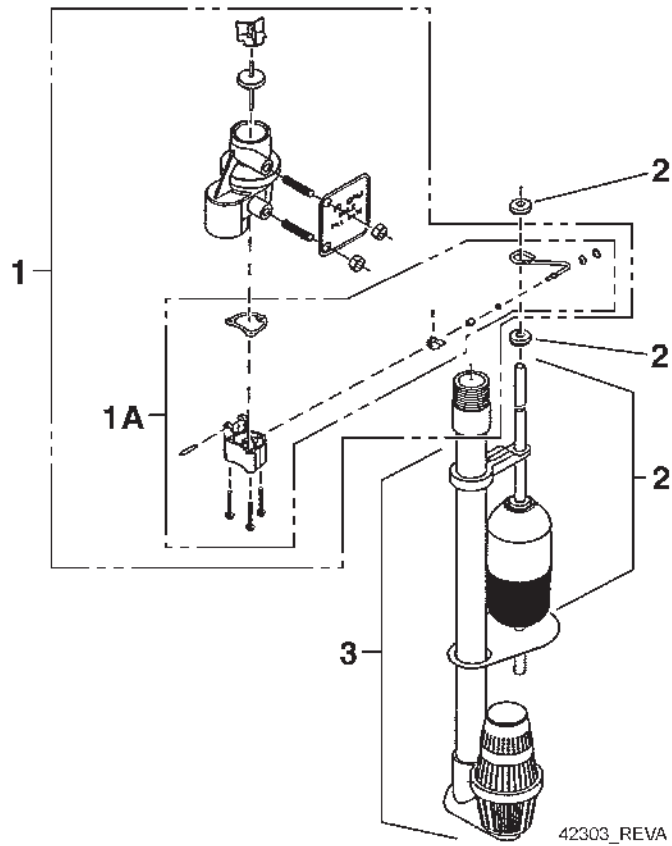

Item No.	QTY	Part No.	Description
1	1	60038	Safety Brine Valve, 2350
1A	1	61024	Actuator Assy, 2350 Brine
2	1	60028-30	Float Assy, 2350, 30-inch Wht
	1	60026-30SAN	Float Assy, 2350, 30-inch Hot Water
3	1	60009-00	Air Check, #900, Commercial Less Fittings
	1	60009-01	Air Check, #900, Commercial, Hot Water Less Fittings

Not Shown

.....	1	18603	Fitting Assy, 900 Air Check 2350
.....	1	18602	Fitting Assy, 900 Air Check

BYPASS VALVE ASSEMBLY (METAL)

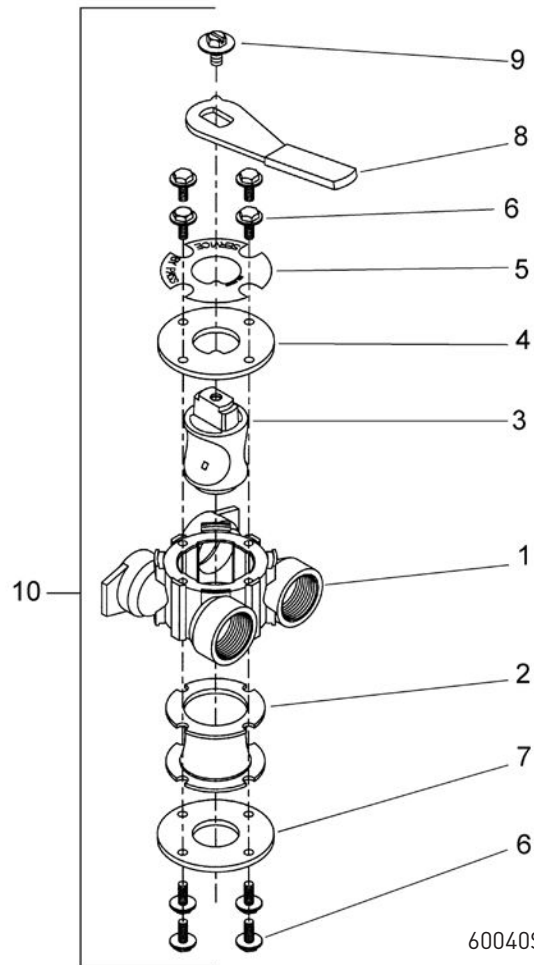

60040SS Rev T
60041SS Rev U

Item No.	QTY	Part No.	Description
1	1	40614	Bypass Body, 3/4-inch
		40634	Bypass Body, 1-inch, SS
2	1	14105	Seal, Bypass, 560CD
3	1	11972	Plug, Bypass
4	1	11978	Side Cover
5	1	13604-01	Label
6	8	15727	Screw, 10-24 x 0.5
7	1	11986	Side Cover
8	1	11979	Lever, Bypass
9	1	11989	Screw, Hex Head, 1/4-14 x 1.5-inch
10	1	60040SS	Bypass Valve, 5600, 3/4-inch NPT Blk Grip Lever, SS
		60041SS	Bypass Valve, 5600, 1-inch NPT Blk Grip Lever, SS
*	2	19228-01	Adapter Assy, Coupling, w/O-rings

*Not Shown

BYPASS VALVE ASSEMBLY (PLASTIC)

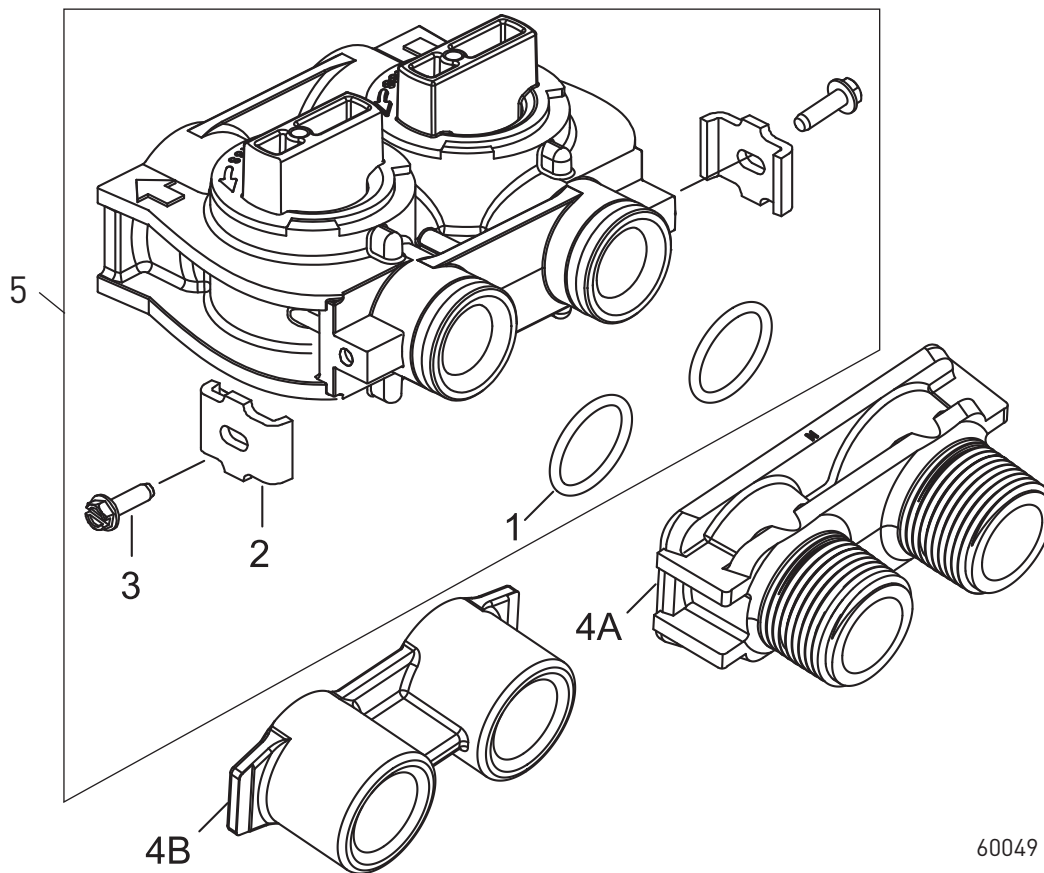

60049 Rev G

Item No.	QTY	Part No.	Description	Item No.	QTY	Part No.	Description
1	2	13305	O-ring, -119	41026-02	1	41026-02	Yoke, 1-inch, BSP, Cast, MACHD, SS
2	2	13255	Clip, Mounting	18706-10	1	18706-10	Yoke, 1-inch, BSP, Plastic
3	2	13314	Screw, Slot Ind Hex, 8-18 x .60	41027-02	1	41027-02	Yoke, 3/4-inch, BSP, Cast, MACHD
4A	1	18706	Yoke, 1-inch, NPT, Plastic	18706-12	1	18706-12	Yoke, 3/4-inch, BSP, Plastic
		18706-02	Yoke, 3/4-inch, NPT, Plastic	19620-01	1	19620-01	Yoke Assy, 3/4-inch, R/Angle, 90 Deg
4B	1	13708-40	Yoke, 1-inch, Sweat	5	1	60049	Bypass Plastic
		13708-45	Yoke, 3/4-inch, Sweat	*	2	19228-01	Adapter Assy, Coupling, w/O-rings
		19275	Yoke, Angle 90 Deg, 3/4-inch, NPT				
		19275-45	Yoke, Angle 90 Deg, 3/4-inch Sweat				
		19620-01	Yoke Assy, 3/4-inch, R/Angle, 90 Deg w/O-rings, Clips & Screws				
		40636	Yoke, 1-1/4 inch, NPT				
		40636-49	Yoke, 1-1/4 inch, Sweat				
		41027-01	Yoke, 3/4-inch, NPT, Cast, Machined				
		41026-01	Yoke, 1-inch, NPT, Cast, Machined, SS				

*Not Shown

GENERAL SERVICE HINTS FOR METER CONTROL

Problem: Softener delivers hard water

Reason: Reserve capacity has been exceeded.

Correction: Check salt dosage requirements and reset program wheel to provide additional reserve.

Reason: Program wheel is not rotating with meter output.

Correction: Pull cable out of meter cover and rotate manually. Program wheel must move without binding and clutch must give positive clicks when program wheel strikes regeneration stop. If it does not, replace timer.

Reason: Meter is not measuring flow.

Correction: Check meter with meter checker.

TROUBLESHOOTING

Problem	Cause	Correction
Water conditioner fails to regenerate.	Electrical service to unit has been interrupted	Assure permanent electrical service (check fuse, plug, pull chain, or switch)
	Timer is defective.	Replace timer.
	Power failure.	Reset time of day.
Hard water.	By-pass valve is open.	Close by-pass valve.
	No salt is in brine tank.	Add salt to brine tank and maintain salt level above water level.
	Injector screen plugged.	Clean injector screen.
	Insufficient water flowing into brine tank.	Check brine tank fill time and clean brine line flow control if plugged.
	Hot water tank hardness.	Repeated flushings of the hot water tank is required.
	Leak at distributor tube.	Make sure distributor tube is not cracked. Check O-ring and tube pilot.
	Internal valve leak.	Replace seals and spacers and/or piston.
Unit used too much salt.	Improper salt setting.	Check salt usage and salt setting.
	Excessive water in brine tank.	See "Excessive water in brine tank".
Loss of water pressure.	Iron buildup in line to water conditioner.	Clean line to water conditioner.
	Iron buildup in water conditioner.	Clean control and add mineral cleaner to mineral bed. Increase frequency of regeneration.
	Inlet of control plugged due to foreign material broken loose from pipes by recent work done on plumbing system.	Remove piston and clean control.
Loss of mineral through drain line.	Air in water system.	Assure that well system has proper air eliminator control. Check for dry well condition.
	Improperly sized drain line flow control.	Check for proper drain rate.
Iron in conditioned water.	Fouled mineral bed.	Check backwash, brine draw, and brine tank fill. Increase frequency of regeneration. Increase backwash time.
Excessive water in brine tank.	Plugged drain line flow control.	Clean flow control.
	Plugged injector system.	Clean injector and screen.
	Timer not cycling.	Replace timer.
	Foreign material in brine valve.	Replace brine valve seat and clean valve.
	Foreign material in brine line flow control.	Clean brine line flow control.
Softener fails to draw brine.	Drain line flow control is plugged.	Clean drain line flow control.
	Injector is plugged.	Clean injector
	Injector screen plugged.	Clean screen.
	Line pressure is too low.	Increase line pressure to 20 psi
	Internal control leak	Change seals, spacers, and piston assembly.
	Service adapter did not cycle.	Check drive motor and switches.
Control cycles continuously.	Misadjusted, broken, or shorted switch.	Determine if switch or timer is faulty and replace it, or replace complete power head.
Drain flows continuously.	Valve is not programming correctly.	Check timer program and positioning of control. Replace power head assembly if not positioning properly.
	Foreign material in control.	Remove power head assembly and inspect bore. Remove foreign material and check control in various regeneration positions.
	Internal control leak.	Replace seals and piston assembly.

9000/9100/9500 METER FLOW DATA

9000 Meter Flow Data

3/4" Mechanical Meter

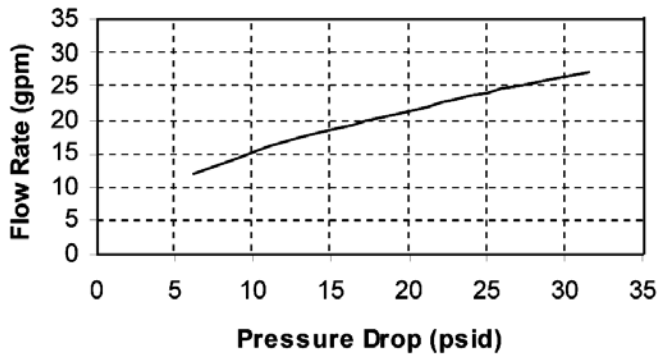

1" Brass Meter

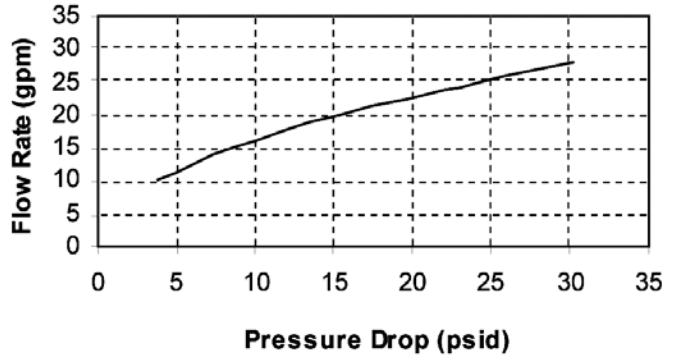

TR: 18467
41092

9100 Meter Flow Data

3/4" Mechanical Meter

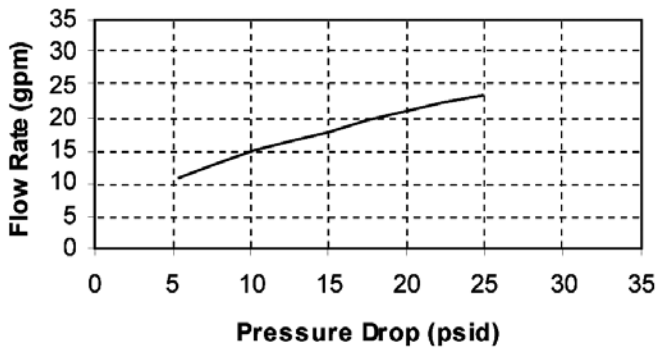

1" Brass Meter

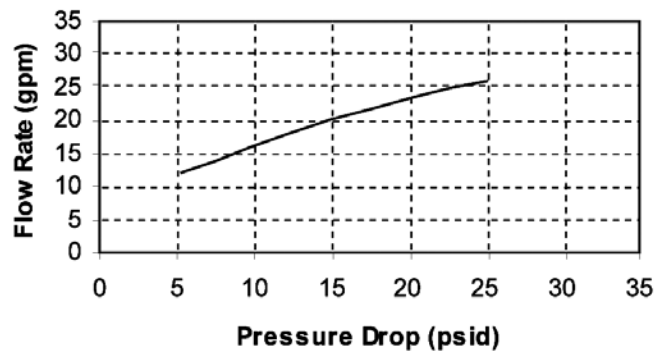

TR: 18467
41092

9500 Meter Flow Data

1 1/2" Meter

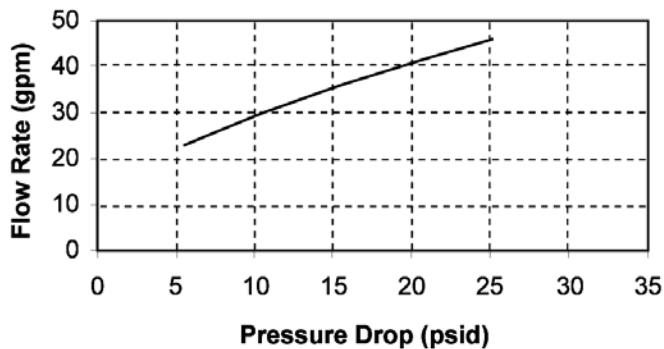

1 1/2" Meter Sleeved

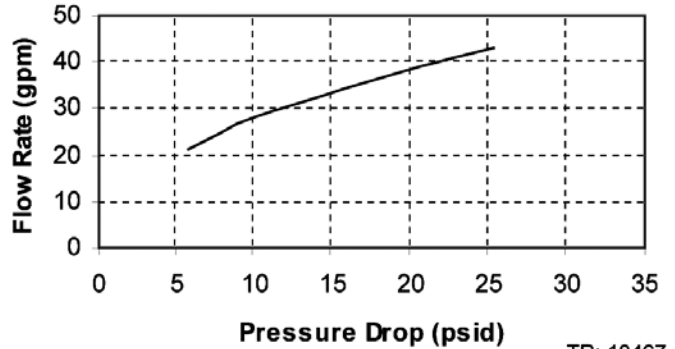

TR: 18467
41092

**9000/9100/9500 INJECTOR FLOW DATA
(1600 SERIES INJECTORS)**

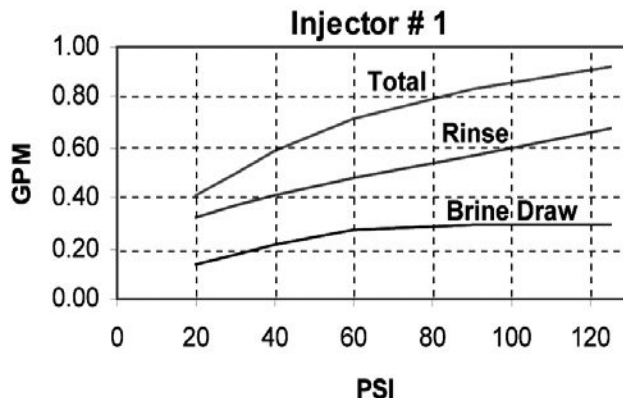
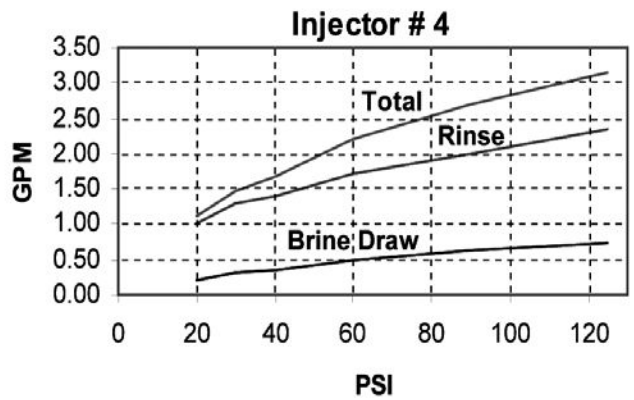
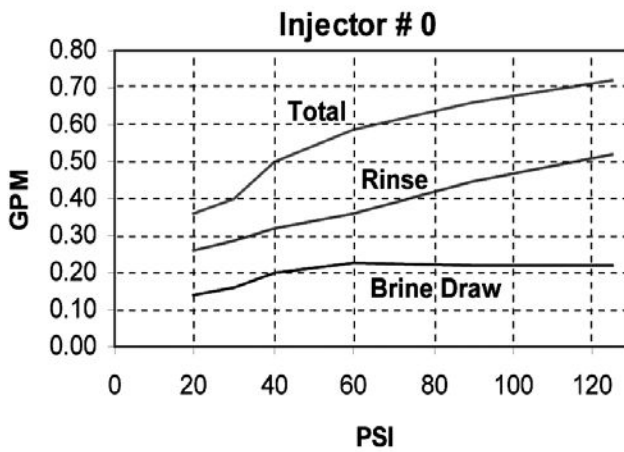
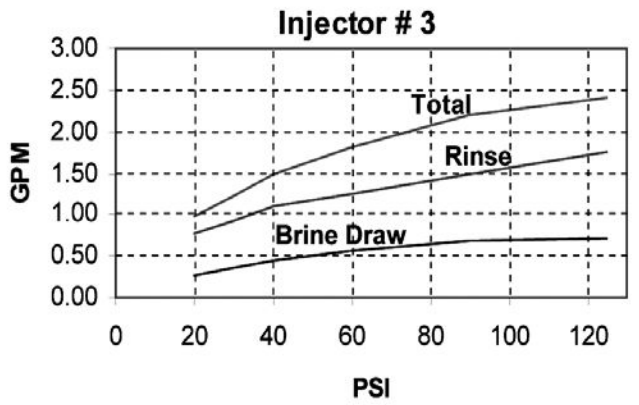
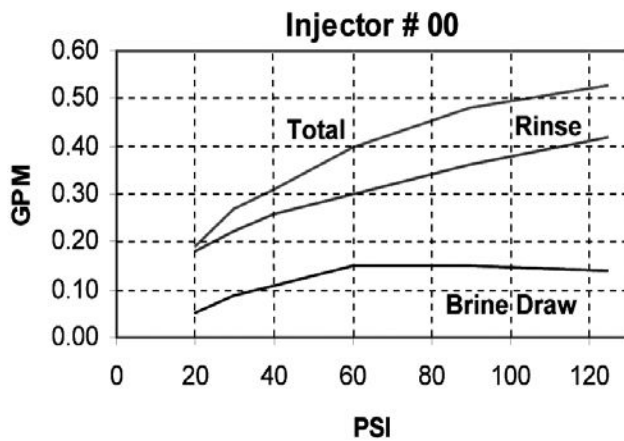
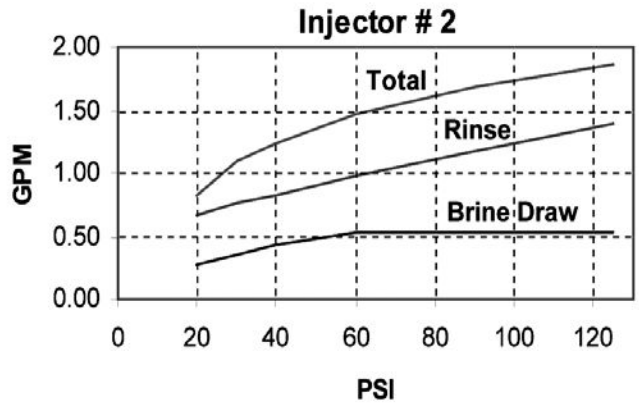
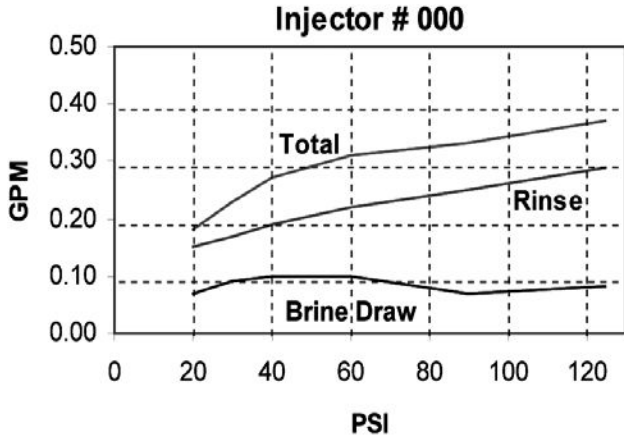

9500 INJECTOR FLOW DATA (1600 & 1700 SERIES INJECTORS)

1600 Series Injectors

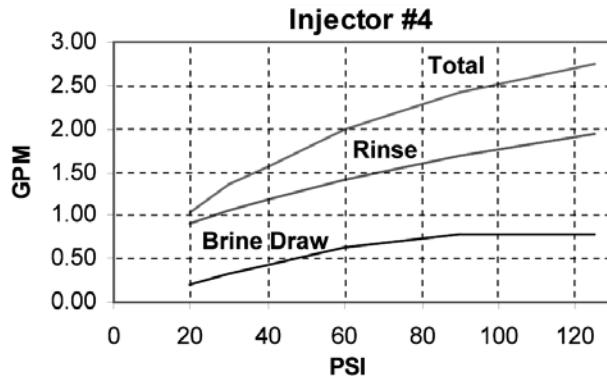
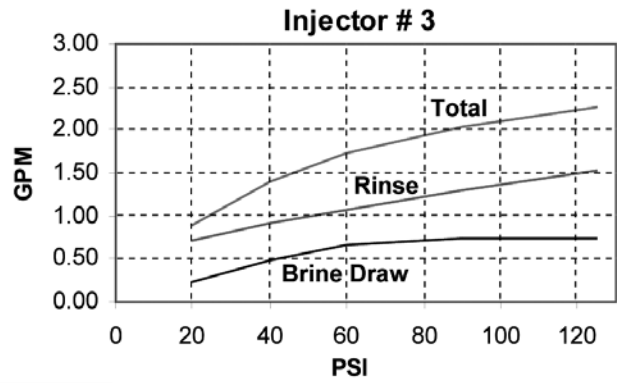
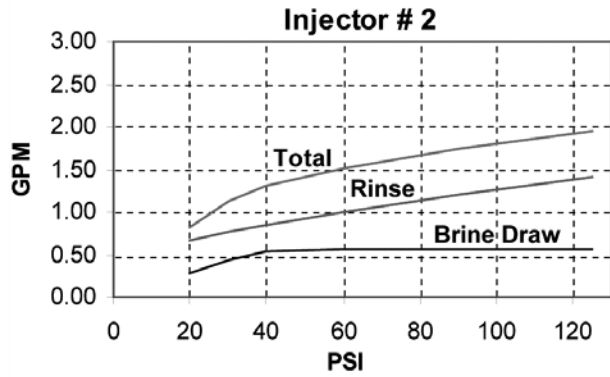

TR: 18467
41092

1700 Series Injectors

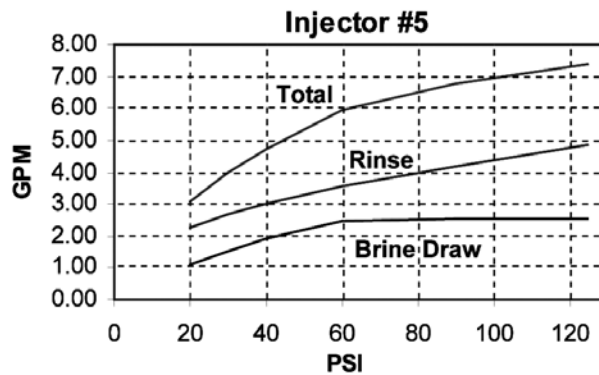
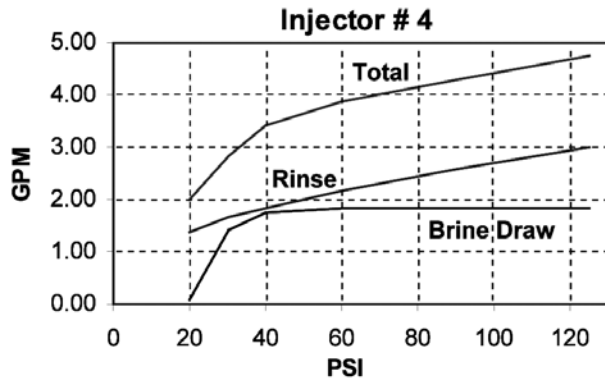
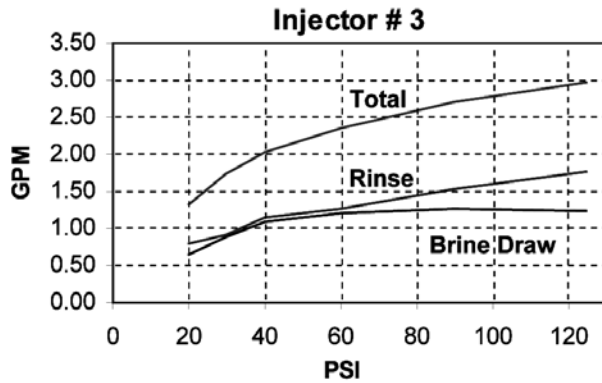

TR: 18467
41092

9000 CONTROL DIMENSIONS

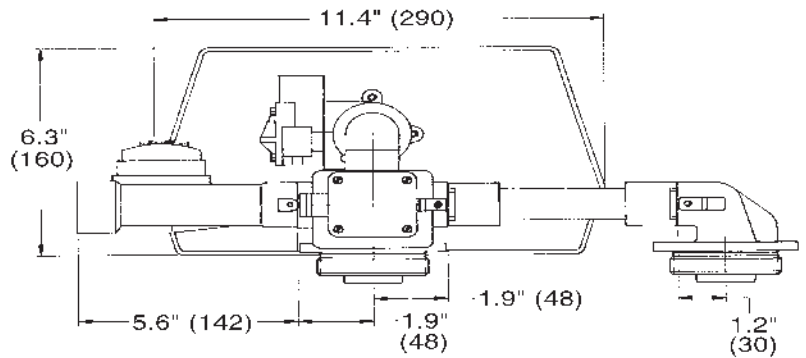
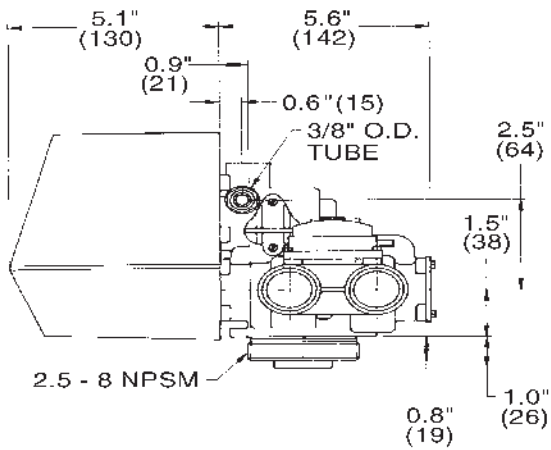
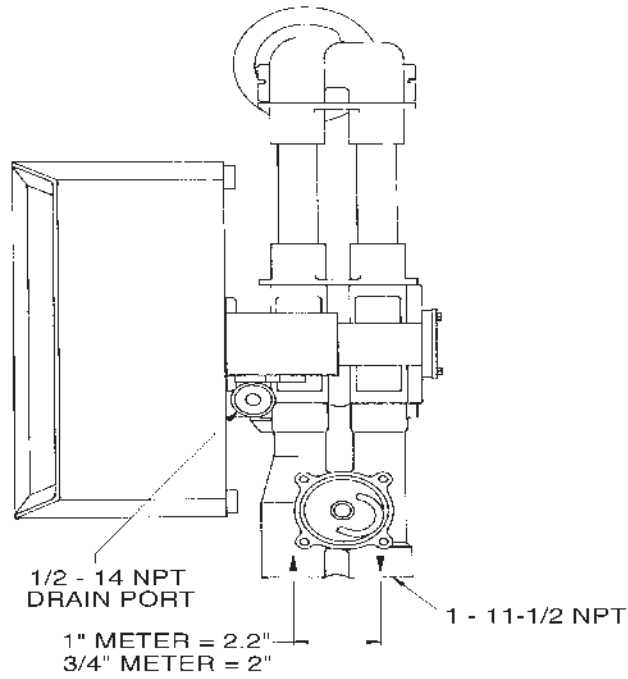

61500-9000LNE_REVA

9100 CONTROL DIMENSIONS

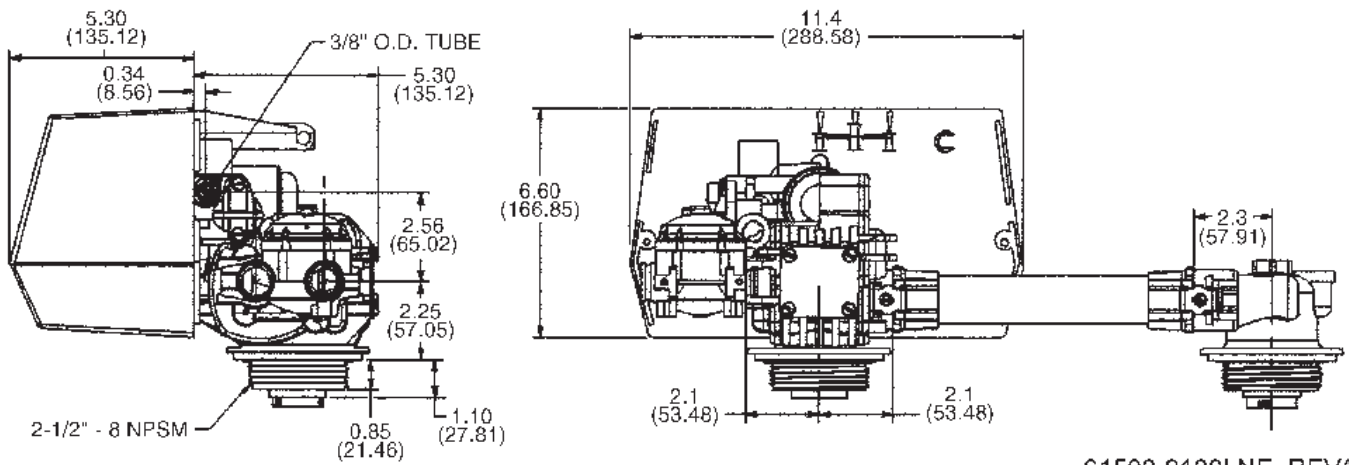
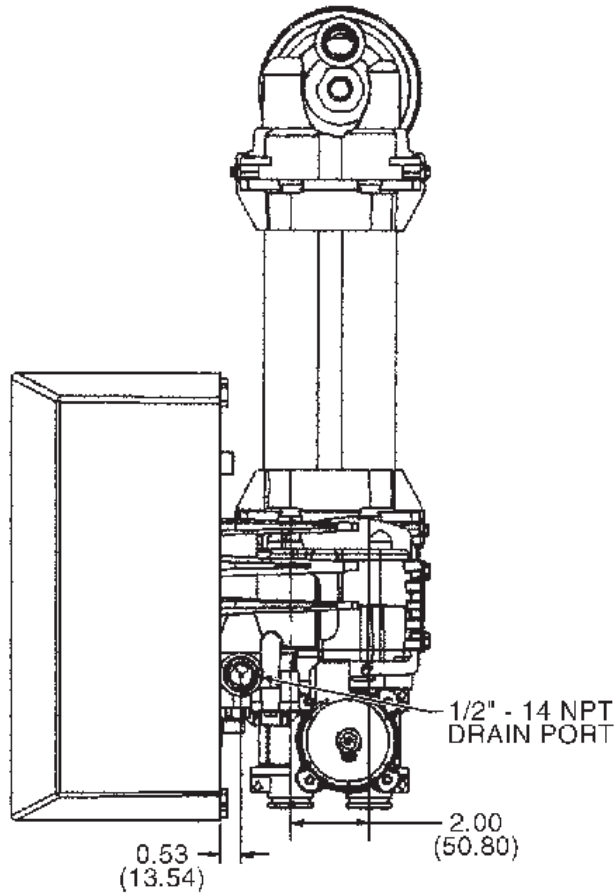

61500-9100LNE_REVA

9500 CONTROL DIMENSIONS

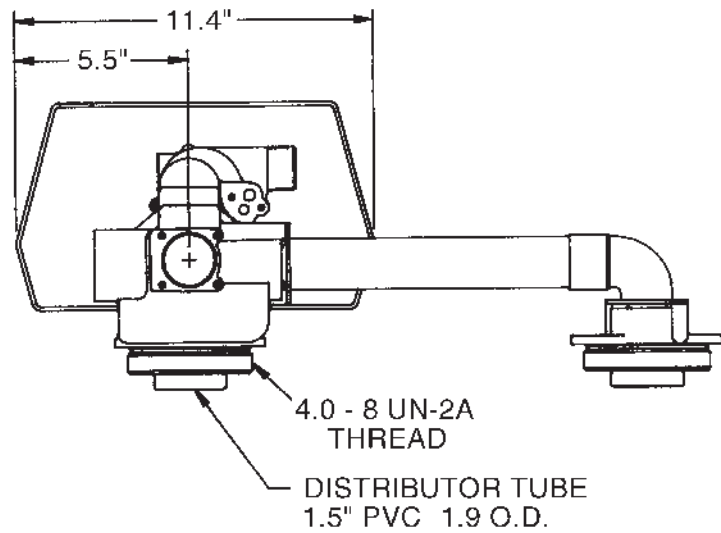
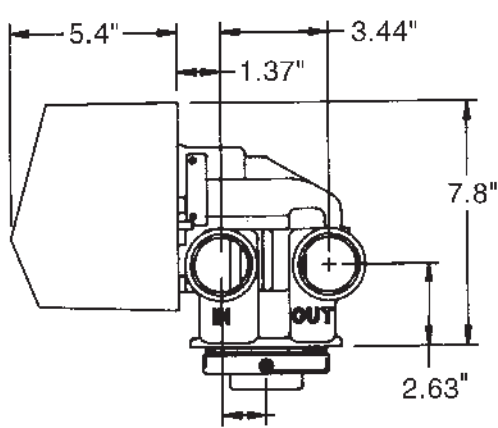
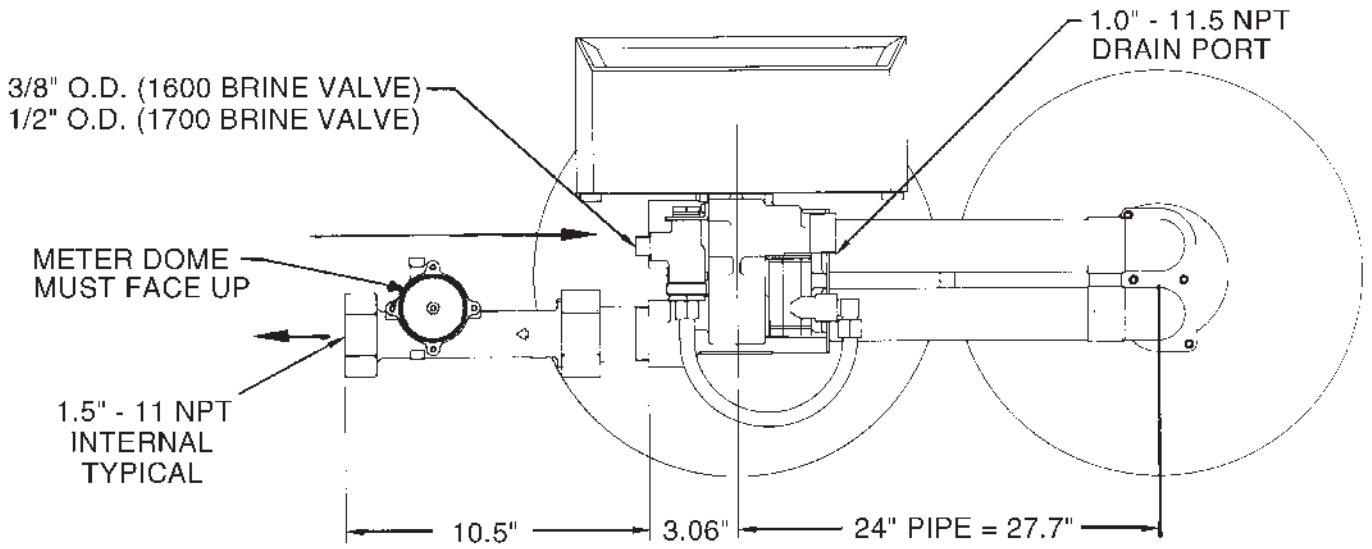

61500-9500LNE_REVA

WATER CONDITIONER FLOW DIAGRAMS

1 In Service Position

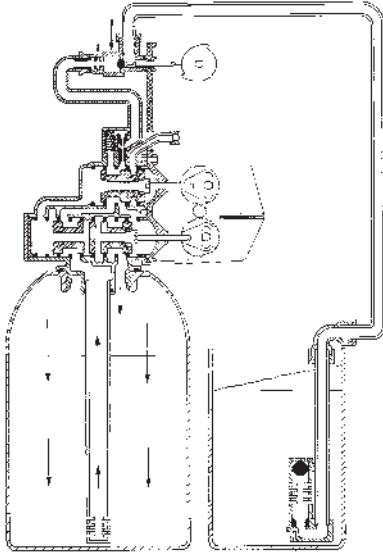

**3 Tanks Switching Position
(Meter Initiated Regeneration)**

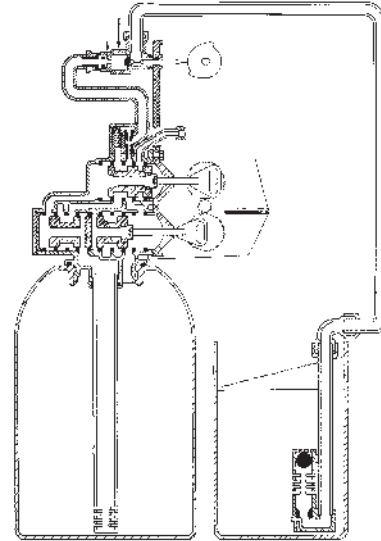

2 Backwash Position

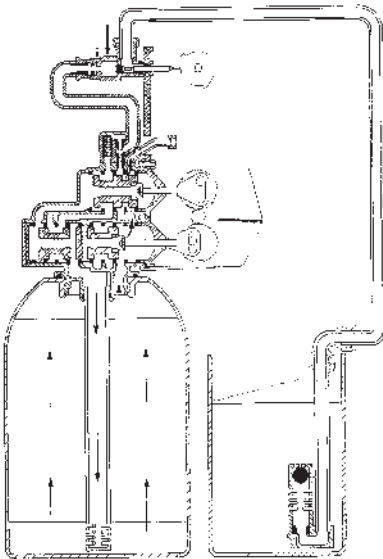

4 Brine Draw Position

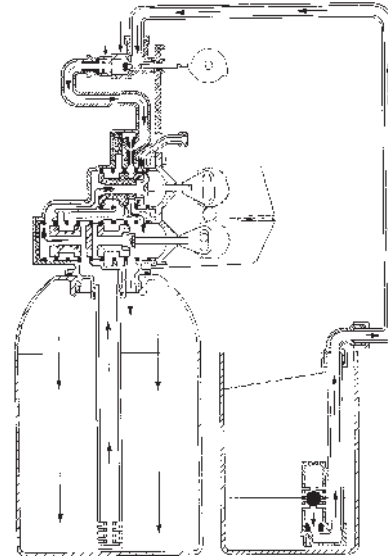

5 Slow Rinse

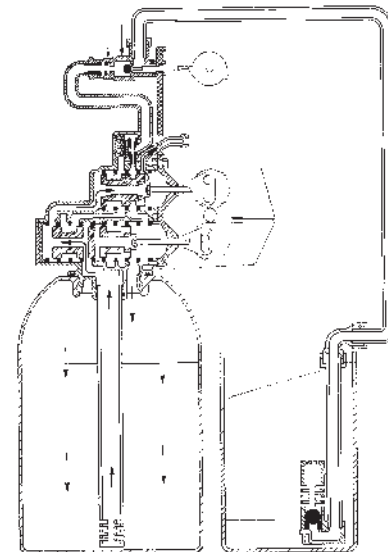

WATER CONDITIONER FLOW DIAGRAMS

CONTINUED

6 Brine Tank Fill Position

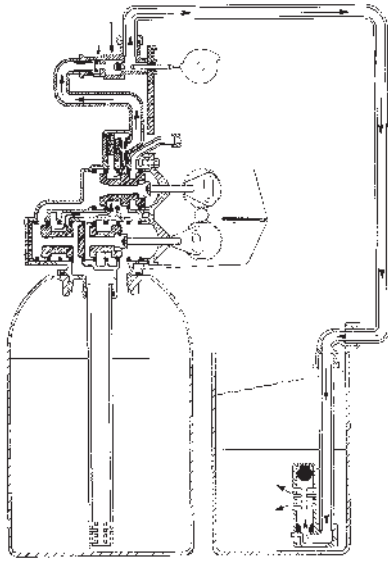

8 In Service Position, Tanks Switched

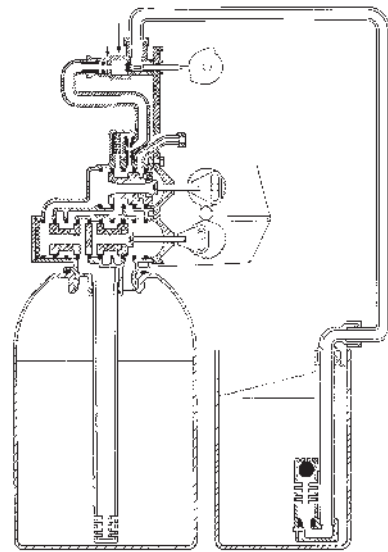

7 Rapid Rinse Position

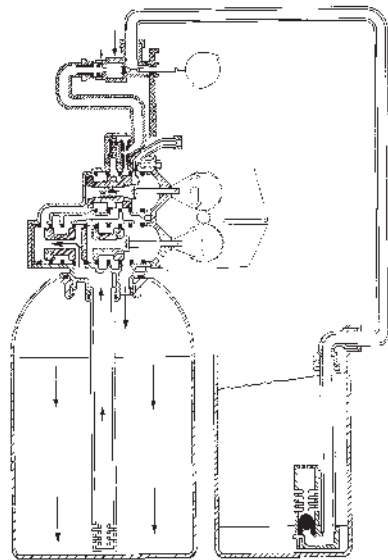

9000/9500 WIRING DIGRAM

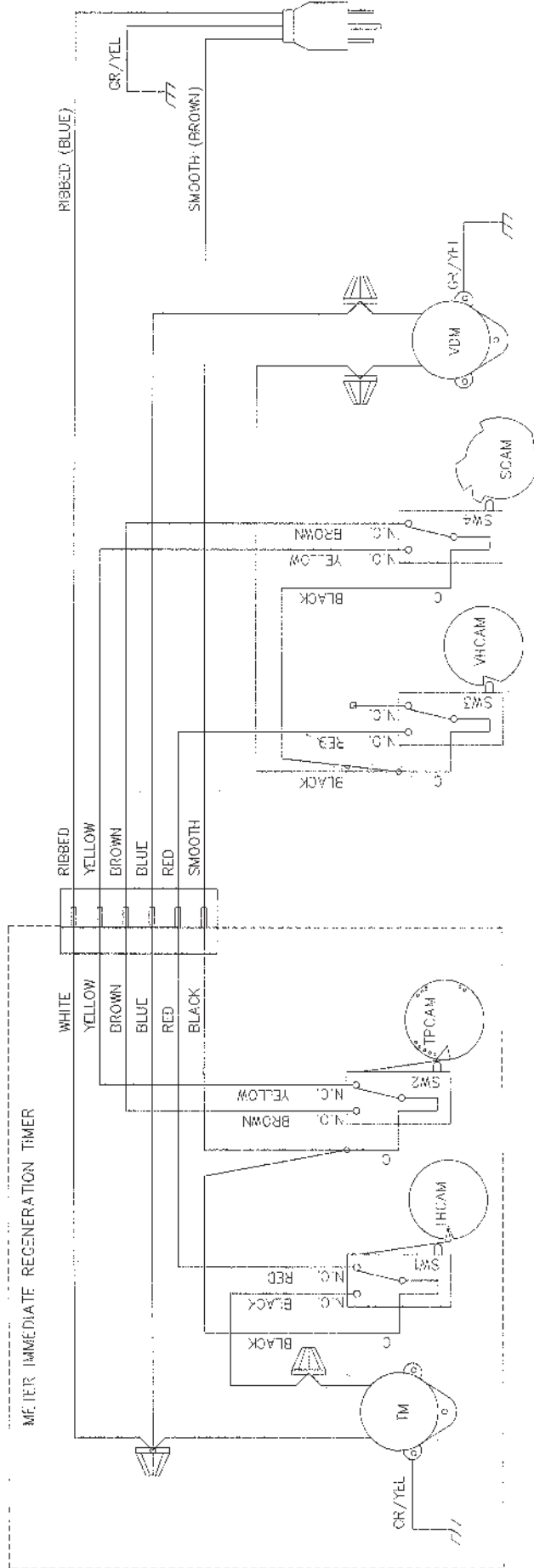

- TM - TIMER MOTOR
- VDM - VALVE DRIVE MOTOR
- SW1 - TIMER HOMING SWITCH
- SW2 - TIMER PROGRAM SWITCH
- SW3 - VALVE HOMING SWITCH
- SW4 - VALVE PROGRAM SWITCH
- TPCAM - TIMER HOMING CAM
- HVCAM - VALVE HOMING CAM
- SCAM - VALVE STEP CAM

NOTE:

1. TWIN TANK METER IMMEDIATE ALTERN REGENERATION.
2. VALVE SHOWN IN SERVICE POSITION.

19752 Rev B

SERVICE ASSEMBLIES

Brine Line Flow Controls (9000/9100):

60022-12	BLFC, .125 GPM, 5000/5600/9000/9100
60022-25	BLFC, .25 GPM, 5000/5600/9000/9100
60022-50	BLFC, .50 GPM, 5000/5600/9000/9100
60022-100	BLFC, 1.0 GPM, 5000/5600/9000/9100
60350	Brine Valve Assy, 9000/9100

Brine Line Flow Controls (9500):

60020-25	BLFC, .25 GPM, 1600
60020-50	BLFC, .50 GPM, 1600
60020-100	BLFC, 1.0 GPM, 1600

Brine Valve Assemblies:

60037-610	Brine Valve, 9500/1600, .25 GPM, Cold & HW 180°
60037-620	Brine Valve, 9500/1600, .50 GPM, Cold & HW 180°
60037-630	Brine Valve, 9500/1600, 1.0 GPM, Cold & HW 180°
60350	Brine Valve Assy 9000/9100, Cold & HW 180°
60350-01	Brine Valve Assy, 9000/9100/Twinfl100, Cold & HW 180°

1700 Brine Valve Assemblies (9500):

60039-XX	Brine Valve, 1700/9500, Cold & HW 180°
----------	-------	--

Bypass Assemblies:

60040SS	Bypass Valve, 5600, 3/4-inch NPT
60041SS	Bypass Valve, 5600, 1-inch NPT
60049	Bypass Plastic Assy

Injector Assemblies (9000/9100):

60385-X	Injector Assembly (specify size of injector)
---------	-------	--

Injector Number DLFC Number BLFC Number

Red #000	Blank0	Blank0
White #101	1.21	0.251
Blue #202	1.52	0.502
Yellow #303	2.03	1.003
Green #404	2.44		
		3.05		
		3.56		
		4.07		
		5.08		
		7.09		

Injector Assemblies (9500):

60381-03	Injector Assy, 1700, #3, Cold & HW 150°
60381-04	Injector Assy, 1700, #4, Cold & HW 150°
60381-05	Injector Assy, 1700, #5, Cold & HW 150°

60381-06	Injector Assy, 1700, #6, Cold & HW 150°
60480-01	Injector Assy, 1600, #1, Plastic, Cold Water
60480-02	Injector Assy, 1600, #2, Plastic, Cold Water
60480-03	Injector Assy, 1600, #3, Plastic, Cold Water
60480-04	Injector Assy, 1600, #4, Plastic, Cold Water
60481-21	Injector Assy, 1600, #1, SS, HW 180°
60481-21	Injector Assy, 1600, #2, SS, HW 180°
60481-21	Injector Assy, 1600, #3, SS, HW 180°
60481-21	Injector Assy, 1600, #4, SS, HW 180°

Meter Assemblies (9000/9100):

15078-01	Adapter, 1-inch Coupling
60086	Meter Assy, 5600/9000/9100, 3/4-inch Std/Range
60087	Meter Assy, 5600/9000/9100, 3/4-inch, Ext
60389	Meter Assy, 9000/9100, 1-inch
60389NP	Meter Assy, 9000/9100, 1-inch, N/P
60389-20	Meter Assy, 9000/9100, 1-inch, BSP/Metric
60390	Meter Assy, 9000/9100, 1-inch, Ext
60390NP	Meter Assy, 9000/9100, 1-inch, Ext, N/P
60390-20	Meter Assy, 9000/9100, 1-inch, Ext/BSP/Metric
60612	Meter Assy, 9000/9100, 1-inch, Std Range, HW 150°
60612NP	Meter Assy, 9000/9100, 1-inch, Std Range, HW 150°, NP
14038	Meter Cap Assy
15150	Meter Cap Assy, Ext
15218	Meter Cap Assy
15218NP	Meter Cap Assy, Std, NP
15237	Meter Cap Assy, Ext
15237NP	Meter Cap Assy, Ext, NP
13509	Impeller, Meter
13509-01	Impeller, Celcon, HW 150°

Meter Assemblies (9500):

60610-01	Meter, 2850/9500, 1-1/2 inch Std
60610-01HW	Meter, 2850/9500, 1-1/2 inch Std, HW 150°
60610-01NP	Meter, 2850/9500, 1-1/2 inch Std, N/P
60610-02	Meter, 2850/9500, 1-1/2 inch Ext
60610-02HW	Meter, 2850/9500, 1-1/2 inch Ext, HW 150°
60610-02NP	Meter, 2850/9500, 1-1/2 inch Ext, N/P
60610-21	Meter, 2850/9500, 1-1/2 inch Std/BSP Metric
60610-21NP	Meter, 2850/9500, 1-1/2 inch Std/BSP Metric, Nickel Plated

SERVICE ASSEMBLIES *CONTINUED*

60610-22	Meter, 2850/9500, 1-1/2 inch Ext/BSP Metric
60610-22NP	Meter, 2850/9500, 1-1/2 inch Ext/BSP Metric/Nickel Plated
60611-01HW	Meter, 2850/9500, 1-inch Sleeve, 1-1/2 inch Std, HW 150°
60611-01	Meter, 2850/9500, 1-inch Sleeve, 1-1/2 inch Std Meter
60611-01NP	Meter, 2850/9500, 1-inch Sleeve, NP 1-1/2 inch Std Meter
60611-02	Meter, 2850/9500, 1-inch Sleeve, 1-1/2 inch Ext Meter
60611-02NP	Meter, 2850/9500, 1-inch Sleeve, NP 1-1/2 inch Ext Meter
17790	Sleeve, Meter, 1-1/2 inch x 1-inch (NOTE: when reducing a 1-1/2 inch meter to a 1-inch meter, the program wheel and timer settings must be changed to a 1-inch meter size)
61933-10	Meter Assy, 1-1/2 inch SS NPT Std
61933-11	Meter Assy, 1-1/2 inch SS NPT Ext
61933-20	Meter Assy, 1-1/2 inch SS BSP Std
61933-21	Meter Assy, 1-1/2 inch SS BSP Ext

Meter Checker Kits:

60460	Meter Checker Kit, Std
60461	Meter Checket Kit, Ext

Piston Assemblies:

60108	Piston Assy, 9500, Upper
60108-01	Piston Assy, 9500, Upper, HW 180°
60109	Piston Assy, 9500, Lower
60109-01	Piston Assy, 9500, Lower HW, 180°
60400	Piston Assy, 9000/9100, Top
60400-01	Piston Assy, 9000/9100, HW Upper, 180°
60401	Piston Assy, 9000/9100, Lower
60401-01	Piston Assy, 9000/9100 Lower, HW 180°

Seal & Spacer Kits:

60125	Seal & Spacer Kit, 5600/9000 Top
60125-20	Seal & Spacer Kit, Top, 559 PE Cold and Chloramine
60125HW	Seal & Spacer Kit, 9000/9100, Upper HW 180°
60133-01	Seal & Spacer Kit, 9500, Lower, Cold & HW 180°
60133-20	Seal & Spacer Kit, 9500, Lower
60134	Seal & Spacer Kit, 9500, Upper, Cold & HW 180°
60134-20	Seal & Spacer Kit, 9500, Upper
60421	Seal & Spacer Kit, 9000/9100, Bottom
60421-20	Seal & Spacer Kit, 9000/9100, Bottom 559PE
60421HW	Seal & Spacer Kit, 9000/9100, Bottom, HW 180°

Second Tank Assemblies (9000):

14202-01	Screw, Hex Washer Mach, 8-32 x 5/16 18-8 S.S.
13255	Clip, Mounting
15078-01	Adapter Assy, 1-inch Coupling
14864-01	Adapter, 9000/9100, 2nd Tank, Machd w/O-rings
14864-01NP	Adapter, 9000/9100, 2nd Tank, Machd, NP
15823-06	Yoke Assy, 6-inch Tank & 6-inch Tube
15823-06NP	Yoke Assy, 6-inch Tank, NP 6-inch Tubes
15823-12	Yoke Assy, 6-inch - 12-inch Tank, 8-1/2 inch Tube
15823-12NP	Yoke Assy, 6-inch - 12" Tank, NP 8-1/2 inch Tubes
15823-14	Yoke Assy, 14-inch Tank, 10-1/2 inch Tube
15823-14NP	Yoke Assy, 14-inch Tank, NP 10-1/2 inch Tube
15823-16	Yoke Assy, 16-inch Tank, 12-1/2 inch Tube
15823-16NP	Yoke Assy, 16-inch Tank, NP 12-1/2 inch Tube

Second Tank Assemblies (9100):

60425-12	Tube Assy, 9100, 6-inch - 12-inch Tanks
60425-16	Tube Assy, 9100, 13-inch - 16-inch Tanks
14865	Adapter Assy, 2nd Tank, 9100
61419	Kit, 1.05-inch Distributor Adapter

Second Tank Assemblies (9500):

16919-01	Valve Body, 9500 Machd
16919-01NP	Valve Body, 9500 Machd, NP
16919-21	Valve Body, 9500 BSP, Mtrc, Machd
16919-21NP	Valve Body, 9500 BSP, Mtrc, Machd Nickel Plated
60715-16	Tube Assy, 9500, 2nd Tank for 14-inch to 16-inch Tanks
60715-16NP	Tube Assy, 9500, 2nd Tank, NP for 14-inch to 16-inch Tanks
60715-20	Tube Assy, 9500, 2nd Tank for 20-inch Tanks
60715-24	Tube Assy, 9500, 2nd Tank for 20-inch and 24-inch Tanks
60715-24NP	Tube Assy, 9500, 2nd Tank, Nickel for 20-inch -24-inch Tanks

Single Piece Plastic End Cap Assemblies

61701-01	Plug Assy, End Cap 9000/9100
61701-02	Plug Assy, End Cap 9500

Tools:

12763	Stuffer Tool Assy, 5600/9000
13061	Puller Assy, Port Ring
13759	Tool, DLFC Retainer

Valve Body Assembly (9100):

40688	Valve Body Assy, 9100
18303	O-ring, -336
18569	Retainer, Tank Seal

For Fleck® Product Warranties visit: }
Fleck para las garantías de los productos visite: } [**waterpurification.pentair.com**](http://waterpurification.pentair.com)
Pour Fleck garanties produit visitez le site : }



13845 BISHOPS DR., SUITE 200, BROOKFIELD, WI 53005
WATERPURIFICATION.PENTAIR.COM | CUSTOMER CARE: 800.279.9404 | tech-support@pentair.com

© 2018 Pentair Residential Filtration, LLC. All rights reserved.

§For a detailed list of where Pentair trademarks are registered, please visit waterpurification.pentair.com/brands. Pentair trademarks and logos are owned by Pentair plc or its affiliates. Third party registered and unregistered trademarks and logos are the property of their respective owners.

40944 REV K MY18

For Fleck® Product Warranties visit:
Fleck para las garantías de los productos visite: } [waterpurification.pentair.com](https://www.waterpurification.pentair.com)
Pour Fleck garanties produit visitez le site :



13845 BISHOPS DR., SUITE 200, BROOKFIELD, WI 53005
WATERPURIFICATION.PENTAIR.COM | CUSTOMER CARE: 800.279.9404 | tech-support@pentair.com

© 2018 Pentair Residential Filtration, LLC. All rights reserved.

§For a detailed list of where Pentair trademarks are registered, please visit [waterpurification.pentair.com/brands](https://www.waterpurification.pentair.com/brands). Pentair trademarks and logos are owned by Pentair plc or its affiliates. Third party registered and unregistered trademarks and logos are the property of their respective owners.

40944 REV K MY18