



FLECK 2850 CONTROL VALVE

SERVICE MANUAL

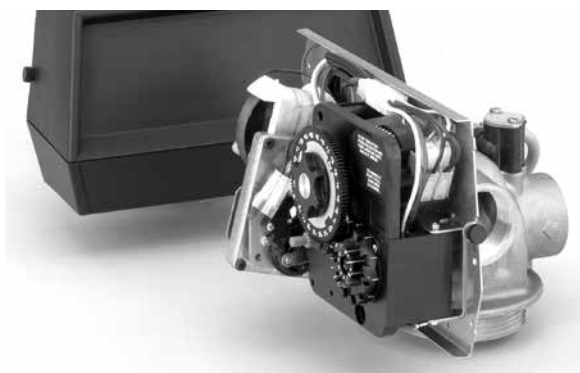

TABLE OF CONTENTS

JOB SPECIFICATION SHEET	2
INSTALLATION	3
START-UP INSTRUCTIONS	3
3200 TIMER SETTING PROCEDURE	4
3210 TIMER SETTING PROCEDURE	4
3200, 3210, 3220, 3230 REGENERATION CYCLE SETTING PROCEDURE	5
3200 TIME CLOCK TIMER ASSEMBLY	6
3210 METER DELAYED TIMER ASSEMBLY	8
3220 METER IMMEDIATE TIMER ASSEMBLY	10
3230 REMOTE START TIMER ASSEMBLY	12
POWERHEAD ASSEMBLY (DESIGNER)	14
POWERHEAD ASSEMBLY (ENVIRONMENTAL).....	16
MANUAL POWERHEAD ASSEMBLY	18
CONTROL VALVE WITH 1700 INJECTOR ASSEMBLY	19
1600 SERIES BRINE SYSTEM	21
1650 BRINE SYSTEM ASSEMBLY	23
1700 BRINE SYSTEM ASSEMBLY	25
1710 BRINE SYSTEM ASSEMBLY	27
1600 SERVICE VALVE OPERATOR ASSEMBLY (OLD STYLE).....	28
1-INCH METER ASSEMBLY	29
1-1/2 INCH METER ASSEMBLY	30
1-1/2 INCH METER ASSEMBLY	31
2300 SAFETY BRINE VALVE	32
2310 SAFETY BRINE VALVE	33
2350 SAFETY BRINE VALVE	34
SEAL & SPACER TOOLS & REPLACEMENT.....	35
GENERAL SERVICE HINTS FOR METER CONTROL.....	36
TROUBLESHOOTING.....	37
WATER CONDITIONER FLOW DIAGRAMS	38
FLOW DATA & INJECTOR DRAW RATES	39
DIMENSIONS.....	40
SYSTEM #4	41
SYSTEM #5 INTERLOCK	41
SYSTEM #6	42
SYSTEM #7	42
SYSTEM #4 WIRING.....	43
SYSTEM #5 WIRING	45
SYSTEM #6 WIRING.....	46
SYSTEM #7 WIRING	47
SERVICE ASSEMBLIES	48

CALIFORNIA PROPOSITION 65 WARNING

⚠ WARNING: This product contains chemicals known to the State of California to cause cancer or birth defects or other reproductive harm.

JOB SPECIFICATION SHEET

Job Number: _____
 Model Number: _____
 Water Hardness: _____ ppm or gpg
 Capacity Per Unit: _____
 Mineral Tank Size: _____ Diameter: _____ Height: _____
 Salt Setting per Regeneration: _____

1. Type of Timer:

- A. 7 Day or 12 Day
- B. Meter Initiated

2. Downflow: Upflow Upflow Variable

3. Meter Size:

- A. 3/4-inch Std Range (125 - 2,100 gallon setting)
- B. 3/4-inch Ext Range (625 - 10,625 gallon setting)
- C. 1-inch Std Range (310 - 5,270 gallon setting)
- D. 1-inch Ext Range (1,150 - 26,350 gallon setting)
- E. 1-1/2 inch Std Range (625 - 10,625 gallon setting)
- F. 1-1/2 inch Ext Range (3,125 - 53,125 gallon setting)
- G. 2-inch Std Range (1,250 - 21,250 gallon setting)
- H. 2-inch Ext Range (6,250 - 106,250 gallon setting)
- I. 3-inch Std Range (3,750 - 63,750 gallon setting)
- J. 3-inch Ext Range (18,750 - 318,750 gallon setting)
- K. Electronic ____ Pulse Count ____ Meter Size _____

4. System Type:

- A. System #4: 1 Tank, 1 Meter, Immediate, or Delayed Regeneration
- B. System #4: Time Clock
- C. System #4: Twin Tank
- D. System #5: 2-5 Tanks, Interlock Mechanical
2-4 Tanks, Interlock Electronic
Meter per unit for Mechanical and Electronic
- E. System #6: 2-5 Tanks, 1 Meter, Series Regeneration, Mechanical
2-4 Tanks, 1 Meter, Series Regeneration, Electronic
- F. System #7: 2-5 Tanks, 1 Meter, Alternating
Regeneration, Mechanical
2 Tanks only, 1 Meter, Alternating
Regeneration, Electronic
- G. System #9: Electronic Only, 2-4 Tanks, Meter per Valve, Alternating
- H. System #14: Electronic Only, 2-4 Tanks, Meter per Valve. Brings units on and offline based on flow.

5. Timer Program Settings:

- A. Backwash: _____ Minutes
- B. Brine and Slow Rinse: _____ Minutes
- C. Rapid Rinse: _____ Minutes
- D. Brine Tank Refill: _____ Minutes
- E. Pause Time: _____ Minutes
- F. Second Backwash: _____ Minutes

6. Drain Line Flow Control: gpm

7. Brine Line Flow Controller: gpm

8. Injector Size#:

9. Piston Type:

- A. Hard Water Bypass
- B. No Hard Water Bypass

INSTALLATION

Water Pressure

A minimum of 20 pounds (1.4 bar) of water pressure is required for regeneration valve to operate effectively.

Electrical Facilities

An uninterrupted alternating current (A/C) supply is required.

NOTE: Other voltages are available. Please make sure your voltage supply is compatible with your unit before installation.

Existing Plumbing

Condition of existing plumbing should be free from lime and iron buildup. Piping that is built up heavily with lime and/or iron should be replaced. If piping is clogged with iron, a separate iron filter unit should be installed ahead of the water softener.

Location Of Softener And Drain

The softener should be located close to a drain to prevent air breaks and back flow.

Bypass Valves

Always provide for the installation of a bypass valve if unit is not equipped with one.

CAUTION Water pressure is not to exceed 125 psi (8.6 bar), water temperature is not to exceed 110°F (43°C), and the unit cannot be subjected to freezing conditions.

Installation Instructions

1. Place the softener tank where you want to install the unit making sure the unit is level and on a firm base.
2. During cold weather, the installer should warm the valve to room temperature before operating.
3. All plumbing should be done in accordance with local plumbing codes. The pipe size for residential drain line should be a minimum of 1/2-inch (13 mm). Backwash flow rates in excess of 7 gpm (26.5 Lpm) or length in excess of 20 feet (6 m) require 3/4-inch (19 mm) drain line. Commercial drain lines should be the same size as the drain line flow control.
4. Refer to the dimensional drawing for cutting height of the distributor tube. If there is no dimensional drawing, cut the distributor tube flush with the top of the tank.
5. Lubricate the distributor o-ring seal and tank o-ring seal. Place the main control valve on tank.

NOTE: Only use silicone lubricant.

6. **⚠ IMPORTANT:** For valves equipped with electromechanical timers and stainless steel meters, refer to the Meter Dome and Union Orientation section.
7. Solder joints near the drain must be done prior to connecting the Drain Line Flow Control fitting (DLFC). Leave at least 6 inches (15 cm) between the DLFC and solder joints when soldering pipes that are connected on the DLFC. Failure to do this could cause interior damage to the DLFC.
8. Plumber tape is the only sealant to be used on the drain fitting. The drain from twin tank units may be run through a common line.

9. Make sure that the floor is clean beneath the salt storage tank and that it is level.
10. Place approximately 1 inch (25 mm) of water above the grid plate. If a grid is not utilized, fill to the top of the air check (Figure 1) in the salt tank. Do not add salt to the brine tank at this time.
11. On units with a by-pass, place in by-pass position. Turn on the main water supply. Open a cold soft water tap nearby and let run a few minutes or until the system is free from foreign material (usually solder) that may have resulted from the installation. Once clean, close the water tap.
12. Slowly place the by-pass in service position and let water flow into the mineral tank. When water flow stops, slowly open a cold water tap nearby and let run until the air is purged from the unit.
13. Plug unit into an electrical outlet.

NOTE: All electrical connections must be connected according to local codes. Be certain the outlet is uninterrupted.

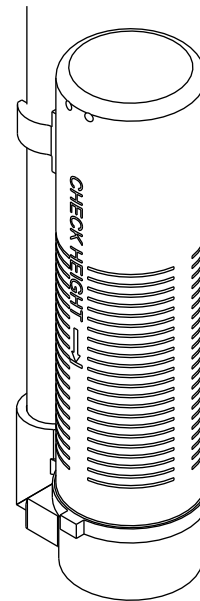

60002 Rev E

INSTALLATION *CONTINUED*

Meter Dome and Union Orientation

Control valves outfitted with an electromechanical timer and stainless steel water meter include a special male x female threaded stainless steel union to insure proper installation and operation of the water meter.

⚠ WARNING: The location of this union in relation to the control valve and water meter is critical for proper operation. DO NOT omit or substitute this special union; it positions the meter dome at the correct distance from the control valve and allows re-positioning the water meter dome for proper operation.

1. Apply a suitable thread sealant to the male threads of the union and meter body.
2. Thread the union into the OUTLET port of the control valve, then thread the meter into the union. See illustrations below.
3. Rotate the water meter body so the meter dome is at the 12 o'clock position. Loosen the nut on the union to facilitate this if required. Once in position, tighten the union nut.
4. Connect the meter cable to the open port in the center of the meter dome.
5. Continue with the installation of the control valve.

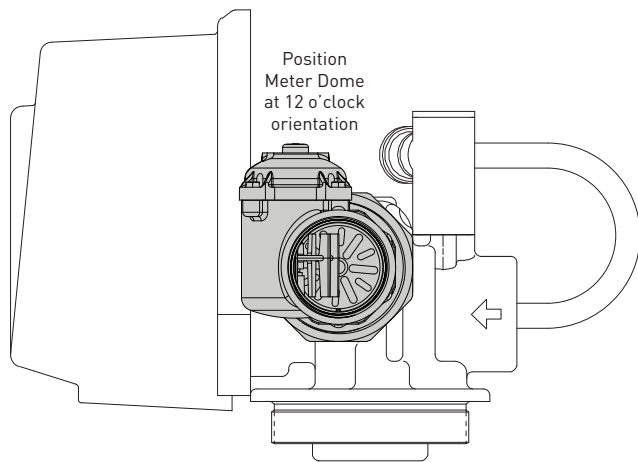
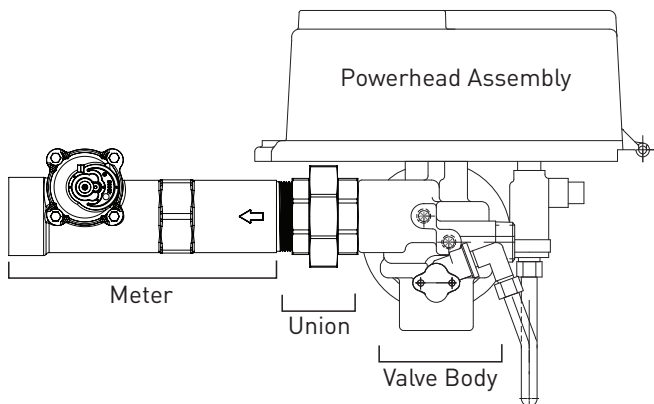

START-UP INSTRUCTIONS

The water softener should be installed with the inlet, outlet, and drain connections made in accordance with the manufacturer's recommendations, and to meet applicable plumbing codes.

1. Turn the manual regeneration knob slowly in a clockwise direction until the program micro switch lifts on top of the first set of pins. Allow the drive motor to move the piston to the first regeneration step and stop. Each time the program switch position changes, the valve will advance to the next regeneration step. Always allow the motor to stop before moving to the next set of pins or spaces.

NOTE: For electronic valves, please refer to the manual regeneration part of the timer operation section. If the valve came with a separate electronic timer service manual, refer to the timer operation section of the electronic timer service manual.

2. Position the valve to backwash. Ensure the drain line flow remains steady for 10 minutes or until the water runs clear (see above).
3. Position the valve to the brine / slow rinse position. Ensure the unit is drawing water from the brine tank (this step may need to be repeated).
4. Position the valve to the rapid rinse position. Check the drain line flow, and run for 5 minutes or until the water runs clear.
5. Position the valve to the start of the brine tank fill cycle. Ensure water goes into the brine tank at the desired rate. The brine valve drive cam will hold the valve in this position to fill the brine tank for the first regeneration.
6. Replace control box cover.
7. Put salt in the brine tank.

NOTE: Do not use granulated or rock salt.

3200 TIMER SETTING PROCEDURE

How To Set Days On Which Water Conditioner Is To Regenerate (Figure 5)

Rotate the skipper wheel until the number "1" is at the red pointer. Set the days that regeneration is to occur by sliding tabs on the skipper wheel outward to expose trip fingers. Each tab is one day. Finger at red pointer is tonight. Moving clockwise from the red pointer, extend or retract fingers to obtain the desired regeneration schedule.

How To Set The Time Of Day

1. Press and hold the red button in to disengage the drive gear.
2. Turn the large gear until the actual time of day is at the time of day pointer.
3. Release the red button to again engage the drive gear.

How To Manually Regenerate Your Water Conditioner At Any Time

1. Turn the manual regeneration knob clockwise.
2. This slight movement of the manual regeneration knob engages the program wheel and starts the regeneration program.
3. The black center knob will make one revolution in the following approximately three hours and stop in the position shown in the drawing.
4. Even though it takes three hours for this center knob to complete one revolution, the regeneration cycle of your unit might be set for only one half of this time.

STARTUP INSTRUCTIONS *CONTINUED*

- In any event, conditioned water may be drawn after rinse water stops flowing from the water conditioner drain line.

How to Adjust Regeneration Time

- Disconnect the power source.
- Locate the three screws behind the manual regeneration knob by pushing the red button in and rotating the 24 hour dial until each screw appears in the cut out portion of the manual regeneration knob.
- Loosen each screw slightly to release the pressure on the time plate from the 24-hour gear.
- Locate the regeneration time pointer on the inside of the 24 hour dial in the cut out.
- Turn the time plate so the desired regeneration time aligns next to the raised arrow.
- Push the red button in and rotate the 24 hour dial. Tighten each of the three screws.
- Push the red button and locate the pointer one more time to ensure the desired regeneration time is correct.
- Reset the time of day and restore power to the unit.

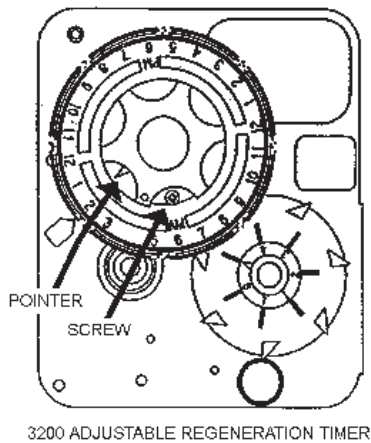
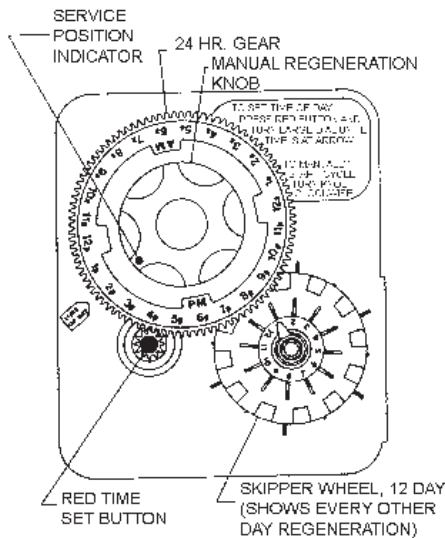

IMPORTANT!
SALT LEVEL MUST ALWAYS BE ABOVE
WATER LEVEL IN BRINE TANK

61502-3200 Rev A

Figure 5

3210 TIMER SETTING PROCEDURE

Typical Programming Procedure

Calculate the gallon capacity of the system, subtract the necessary reserve requirement and set the gallons available opposite the small white dot on the program wheel gear (Figure 6).

NOTE: Drawing shows 8,750 gallon setting. The capacity (gallons) arrow (15) shows zero gallons remaining. The unit will regenerate tonight at the set regeneration time.

How To Set The Time Of Day

- Press and hold the red button in to disengage the drive gear.
- Turn the large gear until the actual time of day is opposite the time of day pointer.
- Release the red button to again engage the drive gear.

How To Manually Regenerate Your Water Conditioner At Any Time

- Turn the manual regeneration knob clockwise.
- This slight movement of the manual regeneration knob engages the program wheel and starts the regeneration program.
- The black center knob will make one revolution in the following approximately three hours and stop in the position shown in the drawing.
- Even though it takes three hours for this center knob to complete one revolution, the regeneration cycle of your unit might be set for only one half of this time.
- In any event, conditioned water may be drawn after rinse water stops flowing from the water conditioner drain line.

Immediate Regeneration Timers

These timers do not have a 24 hour gear. Setting the gallons on the program wheel and manual regeneration procedure are the same as previous instructions. The timer will regenerate as soon as the capacity gallons reaches zero.

NOTE: The program wheel to the left may be different than the program wheel on the product.

NOTE: To set meter capacity rotate manual knob one - 360° revolution to set gallonage.

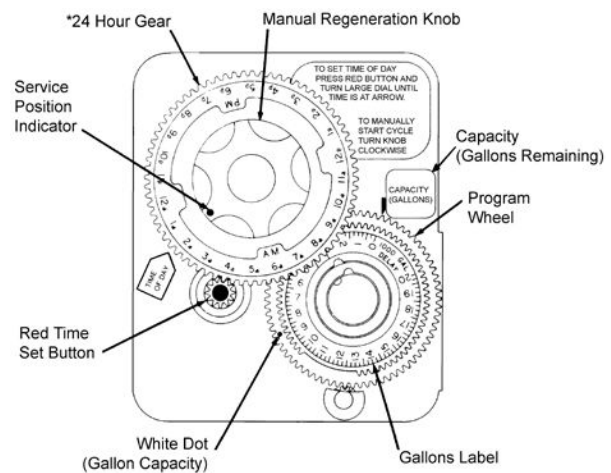

*Immediate regeneration timers do not have a 24-hour gear. No time of day can be set.

Figure 6

61502-3200 Rev A

3200, 3210, 3220, 3230 REGENERATION CYCLE SETTING PROCEDURE

How To Set The Regeneration Cycle Program

The regeneration cycle program on your water conditioner has been factory preset, however, portions of the cycle or program may be lengthened or shortened in time to suit local conditions.

3200 Series Timers (Figure 7)

1. To expose cycle program wheel, grasp timer in upper left-hand corner and pull, releasing snap retainer and swinging timer to the right.
2. To change the regeneration cycle program, the program wheel must be removed. Grasp program wheel and squeeze protruding lugs toward center, lift program wheel off timer. Switch arms may require movement to facilitate removal.
3. Return timer to closed position engaging snap retainer in back plate. Make certain all electrical wires locate above snap retainer post.

Timer Setting Procedure

How To Change The Length Of The Backwash Time

The program wheel as shown in the drawing is in the service position. As you look at the numbered side of the program wheel, the group of pins starting at zero determines the length of time your unit will backwash.

For example, if there are six pins in this section, the time of backwash will be 12 min. (2 min. per pin). To change the length of backwash time, add or remove pins as required. The number of pins times two equals the backwash time in minutes.

How To Change The Length Of Brine And Rinse Time

1. The group of holes between the last pin in the backwash section and the second group of pins determines the length of time that your unit will brine and rinse (2 min. per hole).
2. To change the length of brine and rinse time, move the rapid rinse group of pins to give more or fewer holes in the brine and rinse section. Number of holes times two equals brine and rinse time in minutes.

How To Change The Length Of Rapid Rinse

1. The second group of pins on the program wheel determines the length of time that your water conditioner will rapid rinse (2 min. per pin).
2. To change the length of rapid rinse time, add or remove pins at the higher numbered end of this section as required. The number of pins times two equals the rapid rinse time in minutes.

How To Change The Length Of Brine Tank Refill Time

1. The second group of holes in the program wheel determines the length of time that your water conditioner will refill the brine tank (2 min. per hole).
2. To change the length of refill time, move the two pins at the end of the second group of holes as required.
3. The regeneration cycle is complete when the outer microswitch is tripped by the two pin set at end of the brine tank refill section.
4. The program wheel, however, will continue to rotate until the inner micro switch drops into the notch on the program wheel.

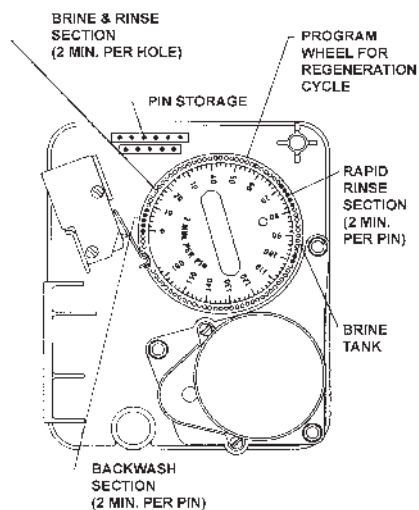
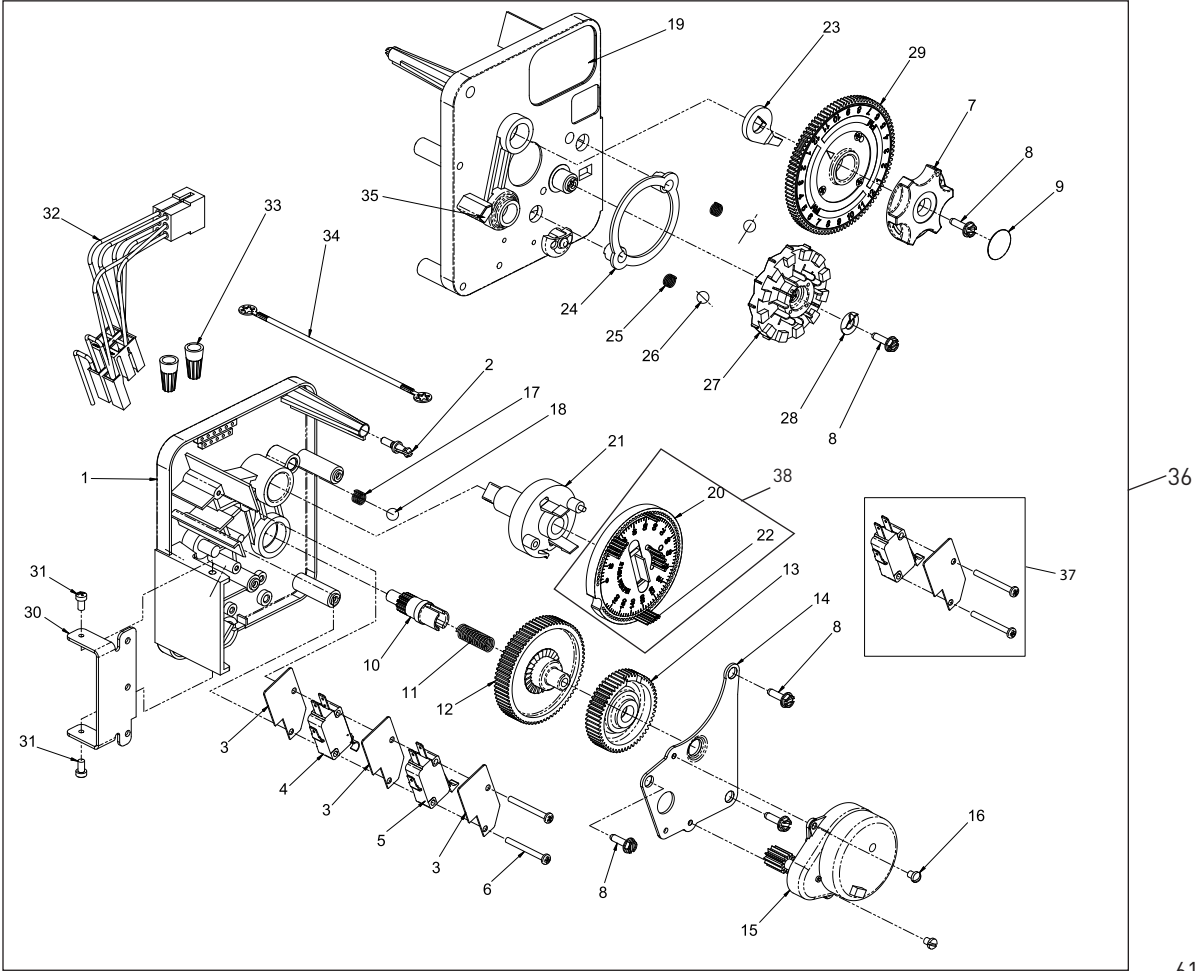

Figure 7

61502-3210 Rev A

[THIS PAGE LEFT INTENTIONALLY BLANK]

3200 TIME CLOCK TIMER ASSEMBLY



615023200 Rev A

3200 TIME CLOCK TIMER ASSEMBLY

CONTINUED

Item No.	QTY	Part No.	Description	Item No.	QTY	Part No.	Description
1	1	13870	Housing, Timer, 3200	27	1	14381	Skipper Wheel Assy, 12 Day
2	1	14265	Clip, Sping		1	14860	Skipper Wheel Assy, 7 Day
3	3	14087	Insulator	28	1	13014	Pointer, Regeneration
4	1	10896	Switch, Micro	29	1	40096-24	Dial, 12 AM Regen Assy, Black
5	1	15320	Switch, Micro, Timer		1	40096-02	Dial, 2 AM Regen Assy, Black
6	2	11413	Screw, Pan Hd Mach, 4-40 x 1-1/8	30	1	13881	Bracket, Hinger Timer
7	1	13886	Knob, 3200	31	2	11384	Screw, Phil, 6-32 x 1/4 Zinc
8	5	13296	Screw, Hex Wsh, 6-20 x 1/2	32	1	13902	Harness, 3200
9	1	11999	Label, Button	33	2	40422	Nut, Wire, Tan
10	1	13018	Pinion, Idler	34	1	15354-01	Wire, Ground, 4 inches
11	1	13312	Spring, Idler Shaft	35	1	14007	Label, Time of Day
12	1	13017	Gear, Idler	36	1	*	Complete 3200 Time Clock Timer Assembly
13	1	13164	Gear, Drive	37		60320-02	Switch Kit, 3200/9000 Timer Auxiliary, Optional
14	1	13887	Plate, Motor Mounting	38		61420-03	Program Wheel, Gear Assy, Filter 2 Min Per Pin
15	1	18743-1	Motor, 120V, 60Hz, 1/30 RPM			61420-04	Program Wheel, Gear Assy, Softener, 2 Min Per Pin
	1	18752-1	Motor, 100V, 50Hz, 1/30 RPM			61420-06	Program Wheel, Gear Assy, Soft Immed, 2 Min Per Pin
	1	18824-1	Motor, 230V, 50Hz, 1/30 RPM			61420-42	Program Wheel, Gear Assy, Filter Immed, 2 Min Per Pin
	1	18826-1	Motor, 24V, 50Hz, 1/30 RPM				
	1	19659-1	Motor, 24V, 60Hz, 1/30 RPM				
	1	19660-1	Motor, 230V, 60Hz, 1/30 RPM				
16	2	13278	Screw, Sltd Fillister Hd 6-32 x .156				
17	1	15424	Spring, Detent, Timer				
18	1	15066	Ball, 1/4-inch, Delrin				
19	1	15465	Label, Caution				
20	1	19210	Program Wheel Assy				
21	1	13911	Gear, Main Drive, Timer				
22	17	41754	Pin, Spring, 1/16 x 5/8 SS, Timer				
23	1	13011	Arm, Cycle Actuator				
24	1	13864	Ring, Skipper Wheel				
25	2	13311	Spring, Detent, Timer				
26	2	13300	Ball, 1/4-inch, SS				

*Call your distributor for Part Number

3210 METER DELAYED TIMER ASSEMBLY

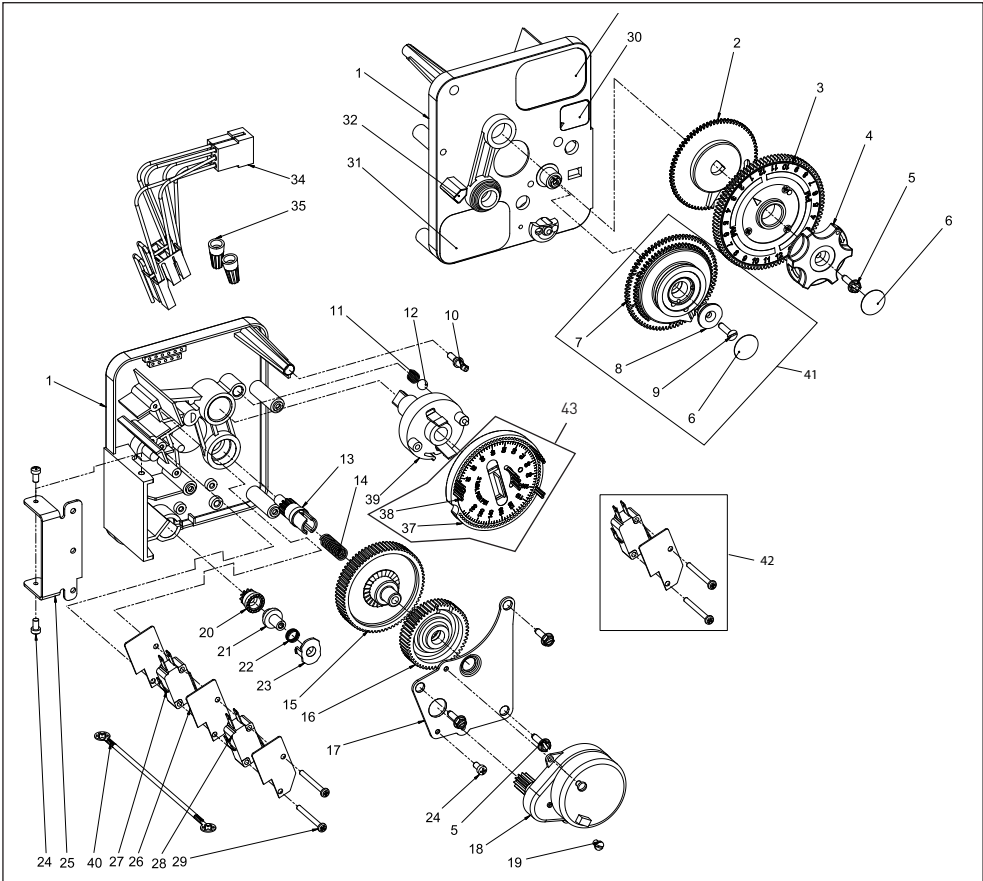

61502-3210 Rev A

3210 METER DELAYED TIMER ASSEMBLY

CONTINUED

Item No.	QTY	Part No.	Description	Item No.	QTY	Part No.	Description
1	1	13870	Housing, Timer, 3200	34	1	13902	Harness, 3200
2	1	13802	Gear, Cycle Actuator	35	2	40422	Nut, Wire, Tan
3	1	40096-02	Dial 2 AM Regen Assy, Black	36	1	15354-01	Wire, Ground, 4 inches
4	1	13886	Knob, 3200	37	1	19210	Program Wheel Assy
5	4	13296	Screw, Hex Wsh, 6-20 x 1/2	38	17	41754	Pin, Spring, 1/16 x 5/8 SS, Timer
6	2	11999	Label, Button	39	1	13911	Gear, Main Drive, Timer
7	1	13803	Gear, Program Drive Wheel	40	1	*	Complete 3210 Meter Delayed Timer Assembly
8	1	13806	Retainer, Program Wheel	41		60405-10	Program Wheel, w/3/4-inch STD Label 0-2,100 gal
9	1	13748	Screw, Flat Head St, 6-20 x 1/2			60405-20	Program Wheel, w/3/4-inch EXT Label 0-10,000 gal
10	1	14265	Clip, Spring			60405-11	Program Wheel, w/3/4-inch STD Metric Label 0-8 m3
11	1	15424	Spring, Detent, Timer			60405-21	Program Wheel, w/3/4-inch EXT Range 0-40 m3
12	1	15066	Ball, 1/4-inch Delrin			??	Program Wheel, w/1-1/2 inch STD Range Label, 0-10,500
13	1	13018	Pinion, Idler			60405-70	Program Wheel, w/1-1/2 inch EXT Range Label, 0-50,000
14	1	13312	Spring, Idler Shaft			??	Program Wheel w/40M ³ , STD Range 1-1/2 inch Meter Label
15	1	13017	Gear, Idler	42		60320-02	Switch Kit, 3200/9000 Timer Auxiliary, Optional
16	1	13164	Gear, Drive	43		61420-03	Program Wheel, Gear Assy, Filter 2 Min Per Pin
17	1	13887	Plate, Motor Mounting			61420-04	Program Wheel, Gear Assy, Softener, 2 Min Per Pin
18	1	18743-1	Motor, 120V, 60Hz, 1/30 RPM			61420-06	Program Wheel, Gear Assy, Soft Immed, 2 Min Per Pin
	1	18752-1	Motor, 100V, 50Hz, 1/30 RPM			61420-42	Program Wheel, Gear Assy, Filter Immed, 2 Min Per Pin
	1	18824-1	Motor, 230V, 50Hz, 1/30 RPM				
	1	18826-1	Motor, 24V, 50Hz, 1/30 RPM				
	1	19659-1	Motor, 24V, 60Hz, 1/30 RPM				
	1	19660-1	Motor, 230V, 60Hz, 1/30 RPM				
19	1	13278	Screw, Fillister Hd, 6-32 x .156				
20	1	13830	Pinion, Program Wheel Drive				
21	1	13831	Clutch, Drive Pinion				
22	1	14276	Spring, Meter, Clutch				
23	1	14253	Retainer, Clutch Spring				
24	3	11384	Screw, Phil, 6-32 x 1/4				
25	1	13881	Bracket, Hinge Timer				
26	3	14087	Insulator				
27	1	10896	Switch, Micro				
28	1	15320	Switch, Micro, Timer				
29	2	11413	Screw, Pan Hd Mach, 4-40 x 1 1/8				
30	1	14198	Label, Indicator				
31	1	15465	Label, Caution				
32	1	14007	Label, Time of Day				
33	1	14045	Label, Instruction				

*Call your distributor for Part Number

3220 METER IMMEDIATE TIMER ASSEMBLY

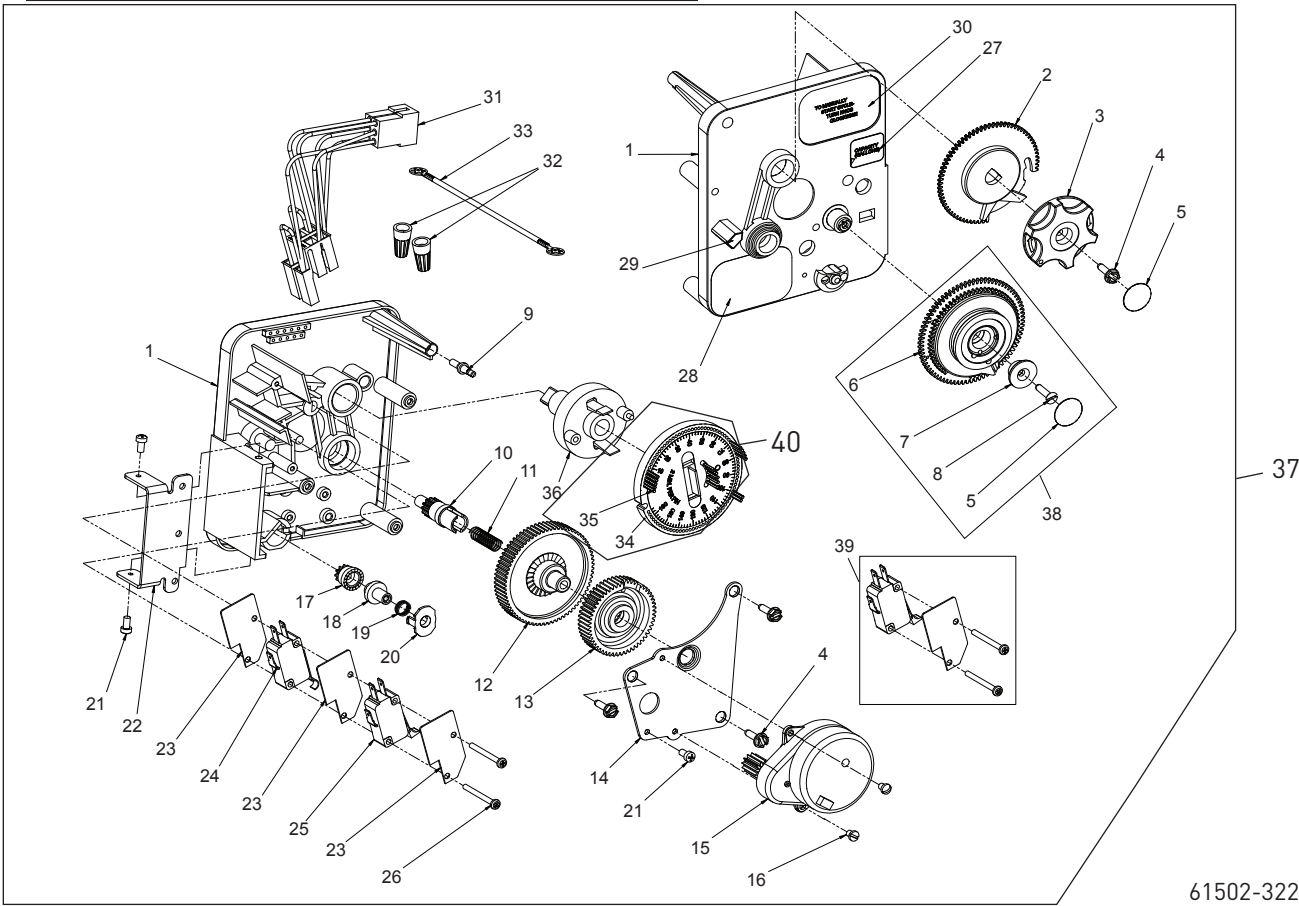

61502-3220 Rev B

3220 METER IMMEDIATE TIMER

ASSEMBLY *CONTINUED*

Item No.	QTY	Part No.	Description	Item No.	QTY	Part No.	Description
1	1	13870	Housing, Timer	34	1	19210-05	Program Wheel Assembly, 9000/3230
2	1	15431	Gear, Cycle Actuator, System #5	35	17	41754	Pin, Spring, 1/16 x 5/8 Stainless Steel, Timer
3	1	13886	Knob, 3200	36	1	15055	Gear, Main Drive
4	4	13296	Screw, Hex Wsh, 6-20 x 1/2	37	1	*	Complete 3220 Meter Immediate Timer Assy
5	2	11999	Label, Button	38		60405-10	Program Wheel, w/3/4-inch STD Label 0-2,100 gal
6	1	13807	Gear, Program Drive Wheel			60405-20	Program Wheel, w/3/4-inch EXT Label 0-10,000 gal
7	1	13806	Retainer, Program Wheel			60405-11	Program Wheel, w/3/4-inch STD Metric Label 0-8 m ³
8	1	13748	Screw, Flt Hd St, 6-20 x 1/2			60405-21	Program Wheel, w/3/4-inch EXT Range 0-40 m ³
9	1	14265	Spring Clip			??	Program Wheel, w/1-1/2 inch STD Range Label, 0-10,500
10	1	13018	Pinion, Idler			60405-70	Program Wheel, w/1-1/2 inch EXT Range Label, 0-50,000
11	1	18563	Idler Shaft Spring			??	Program Wheel w/40 m ³ , STD Range 1-1/2 inch Meter Label
12	1	13017	Gear, Idler	39		60320-02	Switch Kit, 3200/9000 Timer Auxiliary, Optional
13	1	13164	Drive Gear	40		61420-03	Program Wheel, Gear Assy, Filter 2 Min Per Pin
14	1	13887	Plate, Motor Mounting			61420-04	Program Wheel, Gear Assy, Softener, 2 Min Per Pin
15	1	18743-1	Motor, 120V, 60 Hz, 1/30 RPM			61420-06	Program Wheel, Gear Assy, Softener Immediate 2 Min Per Pin
	1	18752-1	Motor, 100V, 50Hz, 1/30 RPM			61420-42	Program Wheel, Gear Assy, Filter Immediate 2 Min Per Pin
	1	18824-1	Motor, 230V, 50Hz, 1/30 RPM	*Call your distributor for Part Number*Call your distributor for Part Number			
	1	18826-1	Motor, 24V, 50Hz, 1/30 RPM				
	1	19659-1	Motor, 24V, 60Hz, 1/30 RPM				
	1	19660-1	Motor, 230V, 60Hz, 1/30 RPM				
16	2	13278	Screw, Slted Fillister Hd				
17	1	14502	Pinion, Program Wheel				
18	1	14501	Clutch, Drive Pinion				
19	1	14276	Meter Clutch Spring				
20	1	14253	Retainer, Clutch Spring				
21	3	11384	Screw, Phil, 6-32 x 1/4 Zinc				
22	1	13881	Bracket, Hinge Timer				
23	3	14087	Insulator				
24	1	15414-00	Micro Switch				
25	1	15320	Switch, Micro, Timer				
26	2	11413	Screw, Pan Hd Mach, 4-40 x 1-1/8				
27	1	14198	Label, Indicator				
28	1	15465	Label, Caution				
29	1	14007	Label, Time of Day				
30	1	15148	Label, Instruction				
31	1	40617	Harness, 3220				
32	2	40422	Nut, Wire, Tan				
33	1	15354-01	Wire, Ground, 4 inches				

3230 REMOTE START TIMER ASSEMBLY

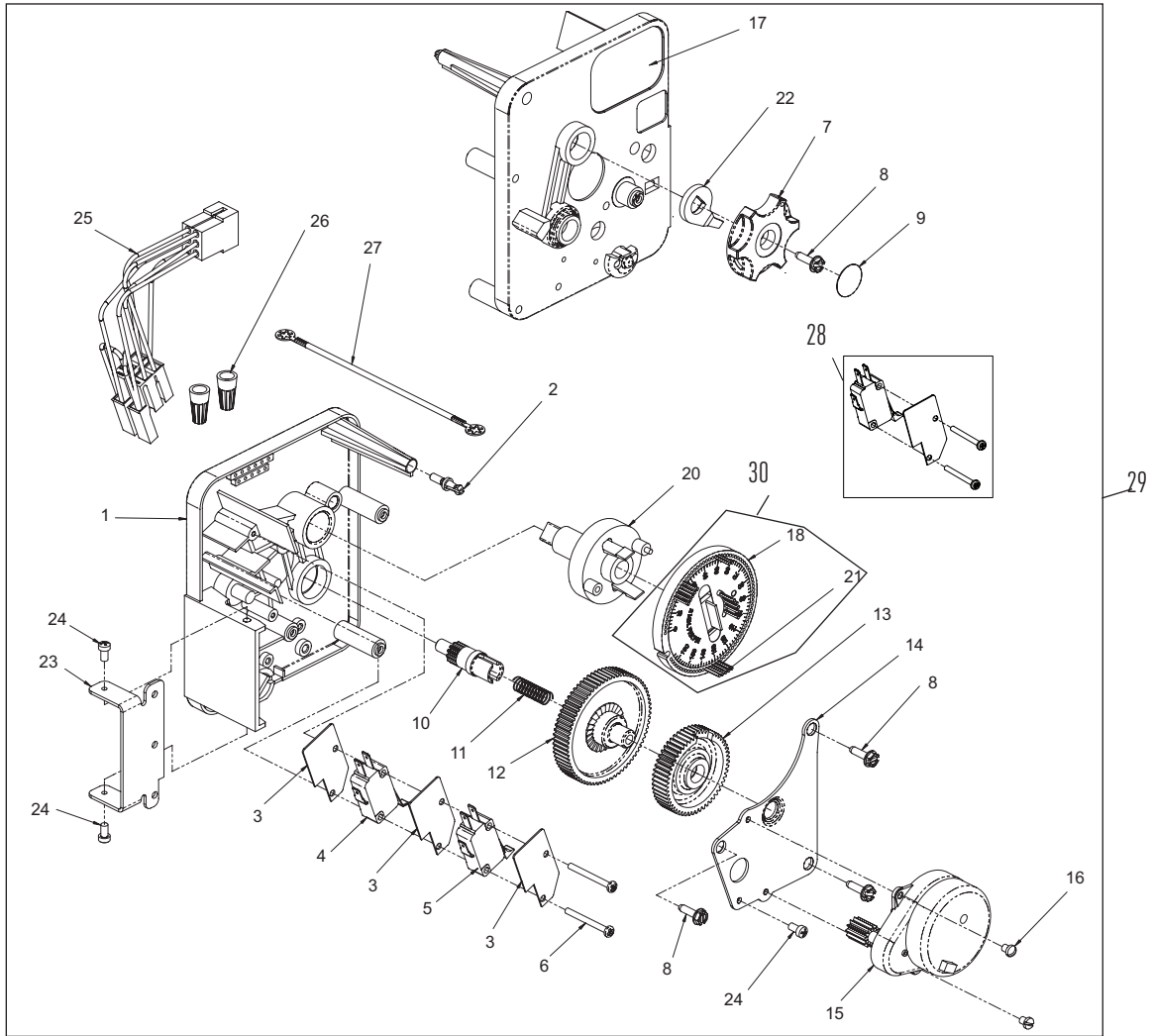

61502-3230R REV A

3230 REMOTE START TIMER ASSEMBLY

CONTINUED

Item No.	QTY	Part No.	Description	Item No.	QTY	Part No.	Description
1	1	13870	Housing, Timer	20	1	15055	Main Drive Gear
2	1	14265	Spring Clip	21	17	41754	Pin, Spring, 1/16 x 5/8 Stainless Steel, Timer
3	3	14087	Insulator	22	1	13011	Cycle Actuator Arm
4	1	15314	Micro Switch	23	1	13881	Bracket, Hinge Timer
5	1	15320	Switch, Micro, Timer	24	3	11384	Screw, Phil, 6-32 x 1/4 Zinc
6	2	11413	Screw, Pan Hd Mach, 4-40 x 1-1/8	25	1	16336	Harness, 3230R
7	1	13886	Knob, 3200	26	2	40422	Nut, Wire, Tan
8	4	13296	Screw, Hex Wsh, 6-20 x 1/2	27	1	15354-01	Wire, Ground, 4 inches
9	1	11999	Label, Button	28		60320-02	Switch Kit, 3200/9000 Timer Auxiliary, Optional
10	1	13018	Pinion, Idler	29	*		3230 Timer Assy
11	1	18563	Idler Shaft Spring	30		61420-06	Program Wheel, Gear Assy, Softener Immediate 2 Min Per Pin
12	1	13017	Gear, Idler			61420-42	Program Wheel, Gear Assy, Filter Immediate 2 Min Per Pin
13	1	15055	Drive Gear				
14	1	13887	Plate, Motor Mounting				
15	1	18743-1	Motor, 120V, 60 Hz, 1/30 RPM				
	1	18752-1	Motor, 100V, 50Hz, 1/30 RPM				
	1	18824-1	Motor, 23V, 50Hz, 1/30 RPM				
	1	18826-1	Motor, 24V, 50Hz, 1/30 RPM				
	1	19659-1	Motor, 24V, 60Hz, 1/30 RPM				
	1	19660-1	Motor, 230V, 60Hz, 1/30 RPM				
16	2	13278	Screw, Sltd Fillister Hd				
17	1	15313	Label, Caution				
18	1	19210-05	Program Wheel Assembly, 3200				

*Call your distributor for Part Number

POWERHEAD ASSEMBLY (DESIGNER)

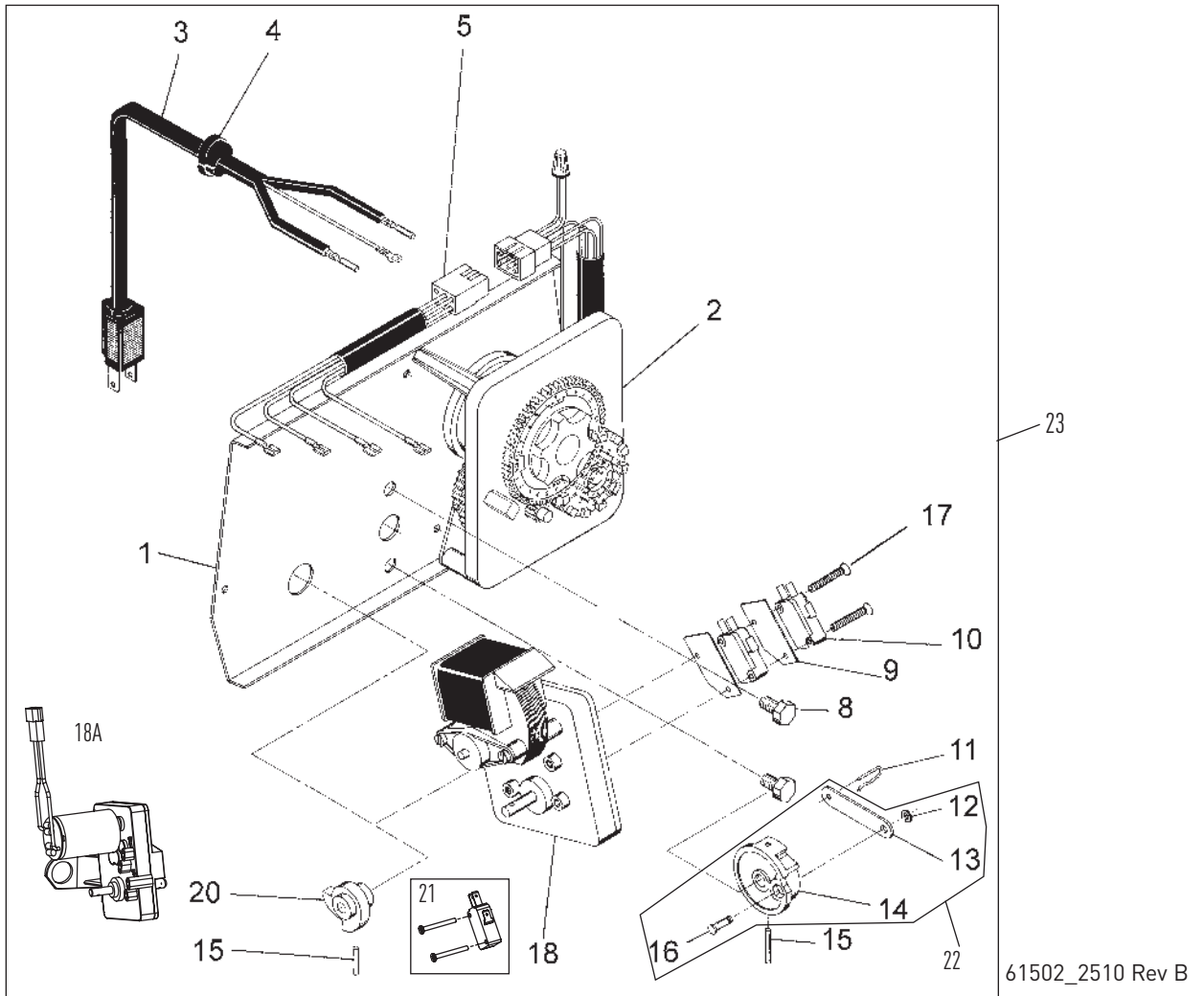

POWERHEAD ASSEMBLY (DESIGNER)

CONTINUED

Item No.	QTY	Part No.	Description
1	1	40264	Backplate, SS/Service Valve Operator, W-T-Screws
2	1		3200, Timer 7 or 12 Day
3	1	11838	Power Cord, North America
		19303-01	Austrailian Cord
		19885-01	Japanese Cord
		11545-01	European Cord
4	1	13547	Strain Relief
5	1	40400	Harness, Drive, Designer/Environmental
8	2	10231	Screw - Drive Mounting
9	2	10302	Insulator
10	2	10218	Switch
11	1	10909	Connecting Link Pin
12	1	10250	Retaining Ring
13	1	10621	Connecting Link
14	1	12576	Drive Cam - STF (Black)
15	2	10338	Roll Pin
16	1	13366	Drive Bearing
17	2	14923	Screw - Switch Mounting
18	1	41543*	Motor, Drive, 115V, 50/60Hz
		41545*	Motor, Drive, 230V, 50/60Hz
18A	1	42579**	Motor, Drive, 24VAC/VDC, 50/60Hz
20	1	12777	Brine Valve Cam - Separate Time Fill (Black)

Item No.	QTY	Part No.	Description
21		***	Switch Kit, 1500 thru 2850, Optional
22	1	60160-15	Drive Cam Assy STF, Blue
23		***	Powerhead Assy

Not Shown:

2		10300	Screw - Timer Mounting
1		13741	Hole Plug
1		17904	Hole Plug
2		19367	Screw, Thumb
1		17470	Cable Guide Assy, 2850
1		17741	Meter Cable, 16.5 inch long, 1-1/2 inch Brass Meter
1		15513	Meter Cable, 17.5 inch long, 1-1/2 inch Stainless Steel Meter
1		60232-110	Cover, Designer, 1 Pc. Black

* Bracket is integrated into the motor.

** Bracket is integrated into the motor and picture may not reflect actual component.

***Call your distributor for Part Number

Motor drawing may not resemble actual.

For Service Assembly Numbers, See the Back of this Manual

POWERHEAD ASSEMBLY (ENVIRONMENTAL)

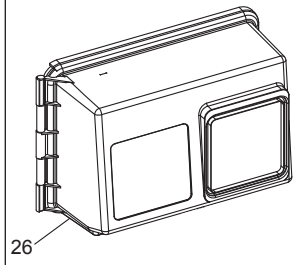
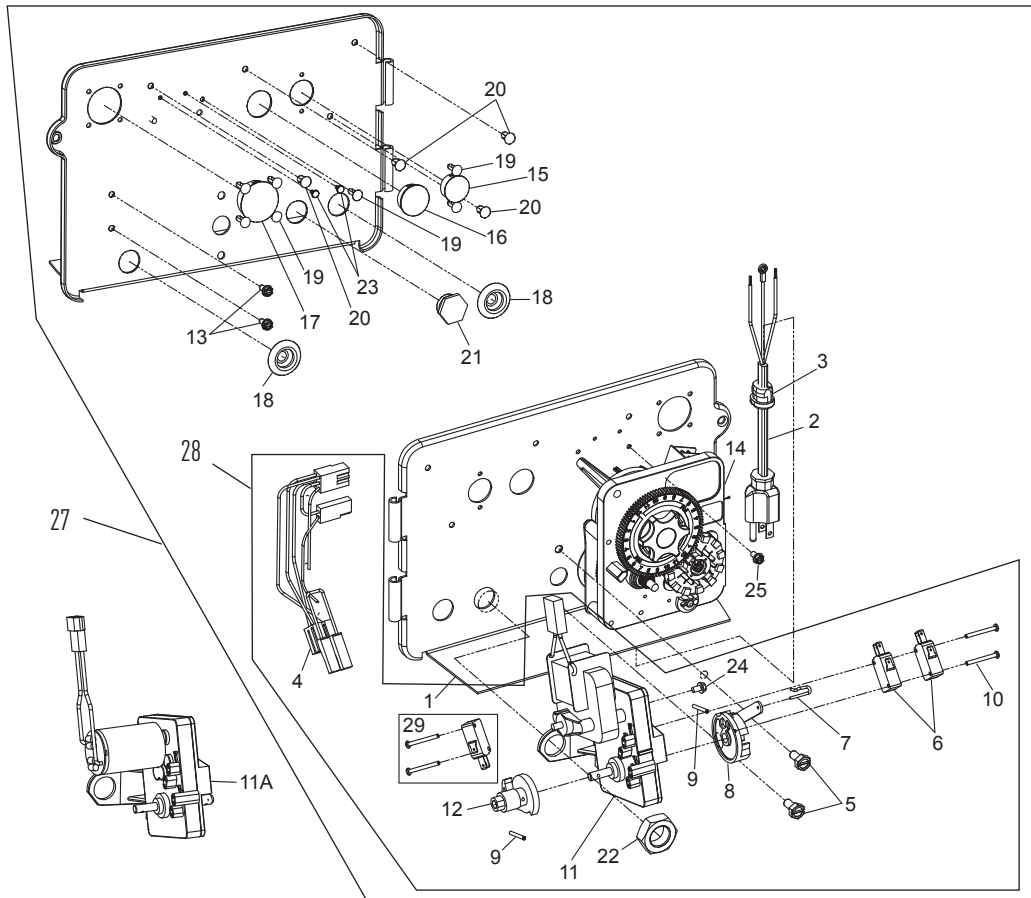

BR61501-1500 Rev C

POWERHEAD ASSEMBLY

(ENVIRONMENTAL) *CONTINUED*

Item No.	QTY	Part No.	Description	Item No.	QTY	Part No.	Description
1	1	18697-15	Backplate, Hinged	23	2	41581	Filter Valves) Wrench Tighten Plug, Hole .125 Dia, White
2	1	11838	Power Cord, 6-foot, North American, Flat	24	1	10872	Screw, Hex WSH, 8-32 x 5/16 20 in-lbs ±20%
		19303-01	Power Cord, 6-foot, Australian	25	1	14202-01	Screw, Hex Washer #8-32 x 5/16 Hand Tighten
		19885-01	Power Cord, 6-foot, Japanese	26	1	60219-02	Cover Assy, Environmental, Black, Clear Window
		11545-01	Power Cord, 6-foot, European			60219-12	Cover Assy, Environmental, Black, Black Window
3	1	13547	Strain Relief, Cord	27	1	*	Powerhead Assembly
4	1	40400	Harness, Drive Designr/ Envirmtl	28	1	60050-23	Drive Motor Assy, 24 VAC/DC, 50-60 Hz FAM 1
5	2	10231	Screw, Slot Hex 1/4-20 x 1/2 35 in-lbs ±20%			60050-21	Drive Motor Assy, 115V/60 Hz
6	2	10218	Switch, Micro			60050-22	Drive Motor Assy, 220V, 50-60 Hz SP FAM1
7	1	10909	Pin, Connecting Rod Spring	29		60320-12	Switch Kit, 1500-2850 Drive Motor
8	1	60160-15	Drive Cam Assy, STF, Blue, 2900	Not Shown:			
9	2	10338	Pin, Roll, 3/32 x 7/8	1		17470	Cable Guide Assy, 2850
10	2	14923	Screw, Pan Hd MACH, 4-40 x 1 5.0 in-lbs ±10%	1		17741	Meter Cable, 16.5 inch long, 1-1/2 inch Brass Meter
11	1	41543	Motor, Drive, 115V/60 Hz	1		15513	Meter Cable, 17.5 inch long, 1-1/2 inch Stainless Steel Meter
		41545	Motor, Drive, 220V, 50-60Hz, SP, Fam 1	*Call your distributor for Part Number			
11A		42579	Motor, Drive, 24 VAC/DC, 50-60 Hz, Fam 1				
12	1	12777	Cam, Shut-off Valve				
13	2	10300	Screw, Hx Wash Head, 8 x 3/8 20 in-lbs ±20%				
14	1	3200	Timer Assy, 3200 7 or 12 Day				
			3210 Meter Delay				
			3220 Meter Immediate				
15	1	15806	Hole Plug, (HeyCo)				
16	1	16493	Plug, Hole, HeyCo, .88 Dia				
17	1	17421	Plug, 1.20 Hole				
18	2	19691	Plug, .750 Dia. Hole, Flush				
19	7	19800	Plug (Hole Size: Dia .140)				
20	4	19801	Plug, Dia .190				
21	1	43560	Fitting, Brine Valve (Used on Filter Valves)				
22	1	10269	Nut, Jam, 3/4-16 (Used on				

MANUAL POWERHEAD ASSEMBLY

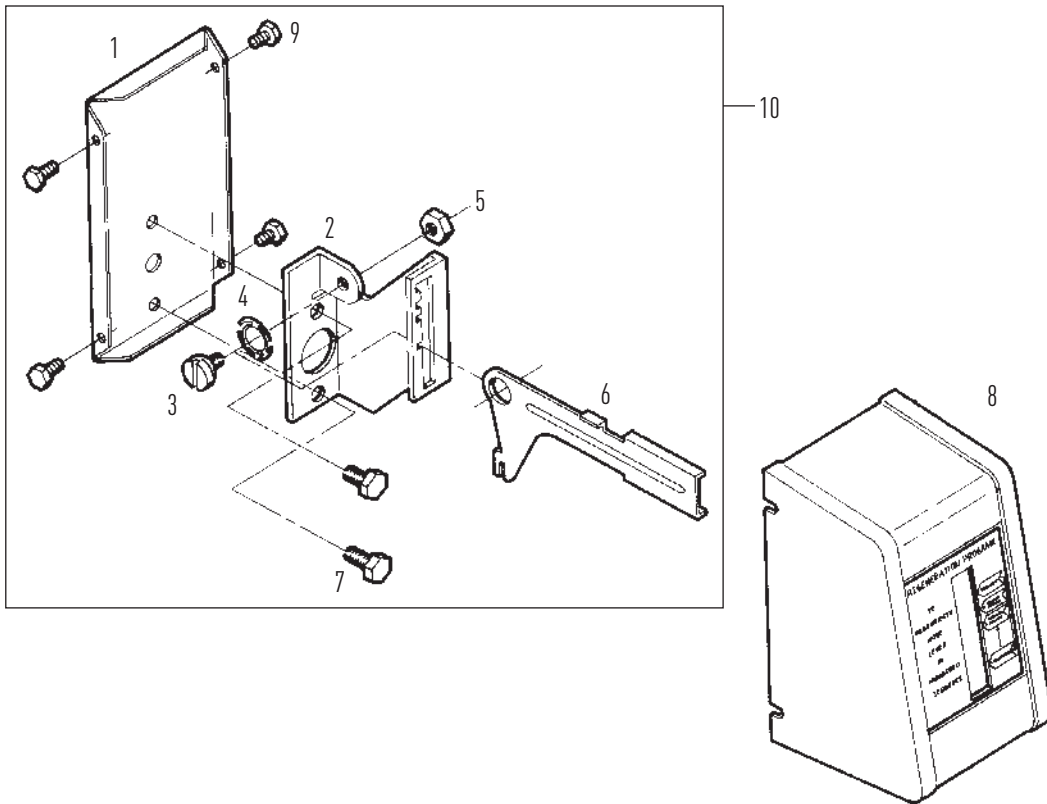

60409 Rev A

Item No.	QTY	Part No.	Description
1	1	12593	Backplate, Manual
2	1	12592	Bracket, Lever Position
3	1	12596	Screw, Spec Mach, 1/4 - 20 x 1/2
4	1	12707	Washer, Spring
5	1	11235	Nut, Hex, 1/4 - 20, Mach Screw, Zinc
6	1	12594	Lever, Valve Position
7	2	10231	Screw, Slot Hex, 1/4 - 20 x 1/2 18-8 SS
8	1	60224-32	Cover Assy, Manual, Filter
	1	60224-33	Cover Assy, Manual, Softener
9	4	10300	Screw, Slot Hex Wsh, 8-18 x 3/8 Type "B" RC44-47
10		60409	Powerhead Assy, Manual

Not Shown:

1		10909	Pin, Link
---	--	-------	-----------

CONTROL VALVE WITH 1700 INJECTOR ASSEMBLY

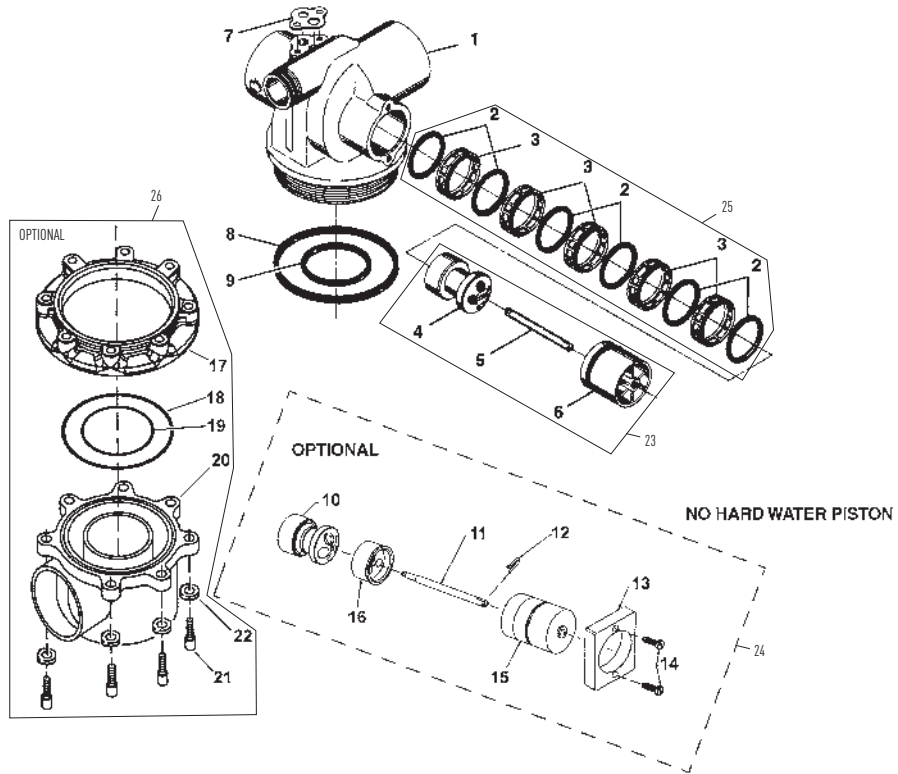

61500-2850 REV D

CONTROL VALVE WITH 1700 INJECTOR

ASSEMBLY *CONTINUED*

Item No.	QTY	Part No.	Description
1	1	16250-01	Valve Body, 2850, Machd
2	6	16101	Seal, 2850
3	5	16638	Spacer, 9500/2850
4	1	19606	Piston, 2850
5	1	16436	Piston, 2850
6	1	16395	End Plug Assy, 2850
	1	16395-01	End Plug Assy, 2850, Hot Water
7	1	14805	Gasket, Injector Body, 1600/1700
8	1	16455	O-ring, -347
*9	1	13577	O-ring, -226
10	1	19606	Piston, 2850,
11	1	19300	Rod, Piston, 2850
12	1	10909	Pin, Link
13	1	19339	Spacer, 2850, NHWBP
14	2	13386	Screw, Hex Hd Mach, 1/4 - 20x1
15	1	16395-02	End Plug Assy/2850, NHWBP
16	1	19298-01	Piston Assy, 2850, NHWBP, O-ring
17	1	40316	Adapter, Sidemount
18	1	40368	O-ring, -160, Sidemount, Flange
19	1	40372	O-ring, -142
20	1	40310	Base, 2850/2900/3930, Rotating
21	7	19768	Screw, Hex Hd, 3/8-16x1, Cap 18-8
22	7	40375	Washer, Flat, 3/8, Type A, N-SERS
23		60105	Piston Assy, 2850 HWBP
		60105-01	Piston Assy, 2850, Hot Water
24		60114-00	Piston Assy, 2850, Filter, Conversion, NHWBP
		60114-01	Piston Assy, 2850, Piston Assy, NHWBP, Replacement
		600114-02	Piston Assy, 2850, Piston Assy, NHWBP, 1600
		60114-03	Piston Assy, 2850, Piston Assy, NHWBP, 1700
25		60129	Seal and Spacer Kit, 2850 Used for Cold and Hot Water
		60129-20	Seal and Spacer Kit, 2850 Plastic Spacers, Chemical Resistant Seal

Item No.	QTY	Part No.	Description
26		61415	Adapter Assy, Sidemount, 2850, 2900 NPT
		61415-20	Adapter Assy, Sidemount, 2850, 2900 BSP

Not Shown

1		60366-00	DLFC 1-inch NPT Blank
		60366-35	DLFC, 1-inch F x 3/4-inch F, NPT, 3.5 gpm Brass
		60366-40	DLFC, 1-inch F x 3/4-inch F, NPT, 4.0 gpm Brass
		60366-45	DLFC, 1-inch F x 3/4-inch F, NPT, 4.5 gpm Brass
		60366-50	DLFC, 1-inch F x 3/4-inch F, NPT, 5.0 gpm Brass
		60366-60	DLFC, 1-inch F x 3/4-inch F, NPT, 60 gpm Brass
		60366-70	DLFC, 1-inch F x 3/4-inch F, NPT, 70 gpm Brass
		60366-8.0	DLFC, 1-inch F x 1-inch F, NPT, 8.0 gpm Brass
		60366-9.0	DLFC, 1-inch F x 1-inch F, NPT, 9.0 gpm Brass
		60366-10	DLFC, 1-inch F x 1-inch F, NPT, 10 gpm Brass
		60366-12	DLFC, 1-inch F x 1-inch F, NPT, 12 gpm Brass
		60366-15	DLFC, 1-inch F x 1-inch F, NPT, 15 gpm Brass
		60366-20	DLFC, 1-inch F x 1-inch F, NPT, 20 gpm Brass
		60366-25	DLFC, 1-inch F x 1-inch F, NPT, 25 gpm Brass
		13640	1-inch F x 1-inch F Flow Control, 30 gpm
		60711-35	DLC, 2-inch, NPT, 35 gpm
		60711-40	DLC, 2-inch, NPT, 40 gpm
		60711-45	DLC, 2-inch, NPT, 45 gpm
1		17996	Disperser, Air, Injector
1		19608-15	Disperser, Commercial 1-1/2 inch 2850/2900/9500

* Do not use O-ring if control is side mounted.

1600 SERIES BRINE SYSTEM

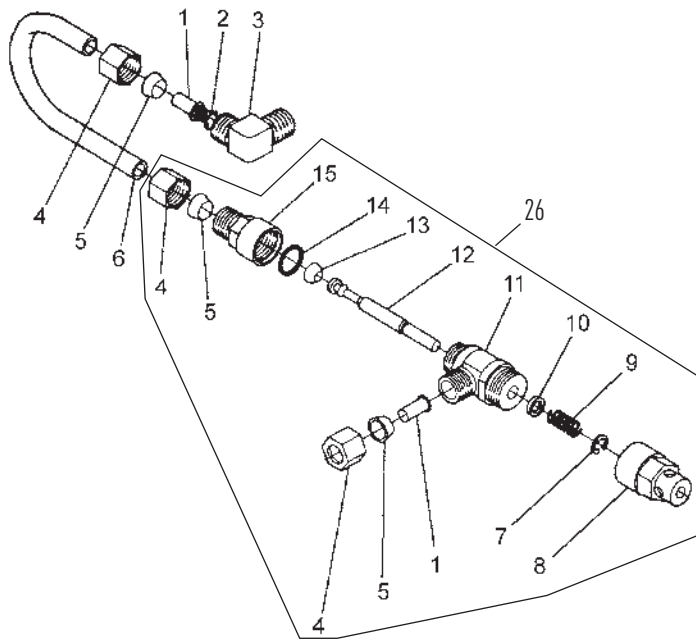

60029 Rev C

Item No.	QTY	Part No.	Description
1	2	10332	Fitting, Insert, 3/8
2	1	12767	Screen, Brine
3	1	10328	Fitting, Elbow, 90 Deg. 1/4 PT x 3/8Tube
4	3	10329	Fitting, Tube, 3/8 Nut, Brass
5	3	10330	Fitting, Sleeve, 3/8 Celcon
6	1	16508	Tube, Brine, 1600, PVC
	1	16508-01	Tube, Brine Valve, 2850/2900s
	1	12774	Tube, Brine Valve, 1500
	1	40027	Tube, Brine Valve, 2510
	1	15221	Tube, Brine Valve, 2750/2900
	1	42184	Tube, Brine Valve, 2850s
	1	41683*	Tube, Brine Valve, UF, 1600/1650
7	1	10250	Ring, Retaining
8	1	11749	Guide, Brine Valve Stem
9	1	10249	Spring, Brine Valve
10	1	12550	Quad Ring, -009
11	1	12748	Brine Valve Body Assy, 1600 w/Quad Ring
12	1	12552-02	Brine Valve Stem, 1600, with seat
13	1	12626	Seat, Brine Valve
14	1	11982	O-ring, -016
15	1	60020-25	BLFC, .25 GPM, 1600

Item No.	QTY	Part No.	Description
1		60020-50	BLFC, .50 GPM, 1600
1		60020-100	BLFC, 1.0 GPM, 1600
16	2	10692	Screw, Slot Hex Hd, 10 - 24X 18-8 Stainless Steel
17	1	11893	Cap, Injector, SS
18	1	10229	Gasket, Injector Cap, 1600
19	1	10227	Screen, Injector
20	1	10913-000	Nozzle, Injector, #000, Brown
		10913-00	Nozzle, Injector, #00, Violet
		10913-0	Nozzle, Injector, #0, Red
		10913-1	Nozzle, Injector, #1, White
		10913-2	Nozzle, Injector, #2, Blue
		10913-3	Nozzle, Injector, #3, Yellow
		10913-4	Nozzle, Injector, #4, Green
		12973-0	Nozzle, Injector, #0, PVC Grey
		12973-1	Nozzle, Injector, #1, PVC Grey
		12973-2	Nozzle, Injector, #2, PVC Grey
		12973-3	Nozzle, Injector, #3, PVC Grey
		12973-4	Nozzle, Injector, #4, PVC Grey
		10225-0	Nozzle, Injector, #0, Stainless

1600 SERIES BRINE SYSTEM *CONTINUED*

Item No.	QTY	Part No.	Description
			Steel
	10225-1Nozzle, Injector, #1, Stainless Steel
	10225-2Nozzle, Injector, #2, Stainless Steel
	10225-3Nozzle, Injector, #3, Stainless Steel
	10225-4Nozzle, Injector, #4, Stainless Steel
211	10914-000Throat, Injector, #000, Brown
	10914-00Throat, Injector, #00, Violet
	10914-0Throat, Injector, #0, Red
	10914-1Throat, Injector, #1, White
	10914-2Throat, Injector, #2, Blue
	10914-3Throat, Injector, #3, Yellow
	10914-4Throat, Injector, #4, Green
	12974-0Throat, Injector, #0, PVC Grey
	12974-1Throat, Injector, #1, PVC Grey
	12974-2Throat, Injector, #2, PVC Grey
	12974-3Throat, Injector, #3, PVC Grey
	12974-4Throat, Injector, #4, PVC Grey
	10226-0Throat, Injector, #0, Stainless Steel
	10226-1Throat, Injector, #1, Stainless Steel
	10226-2Throat, Injector, #2, Stainless Steel
	10226-3Throat, Injector, #3, Stainless Steel
	10226-4Throat, Injector, #4, Stainless Steel
221	17776Body, Injector, 1600
	1	17776-02*Body, Injector, 1600 Upflow
231	16221Dispenser, Air
241	14805Gasket, Injector Body, 1600/1700
25	60480-01Injector Assy, 1600, #1 Plastic
	60480-02Injector Assy, 1600, #2 Plastic
	60480-03Injector Assy, 1600, #3 Plastic
	60480-04Injector Assy, 1600, #4 Plastic
	60481-21Injector Assy, 1600, #1, S.S. Brass
	60481-22Injector Assy, 1600, #2, S.S. Brass
	60481-23Injector Assy, 1600, #3, S.S. Brass
	60080-11Injector Assy, 1600, #1, PVC
	60080-12Injector Assy, 1600, #2, PVC
	60080-14Injector Assy, 1600, #4, PVC
26	60029-010Brine Valve, 1600, 0.25 gpm
	60029-020Brine Valve, 1600, 0.50 gpm
	60029-030Brine Valve, 1600, 1.0 gpm

*Upflow Only

1650 BRINE SYSTEM ASSEMBLY

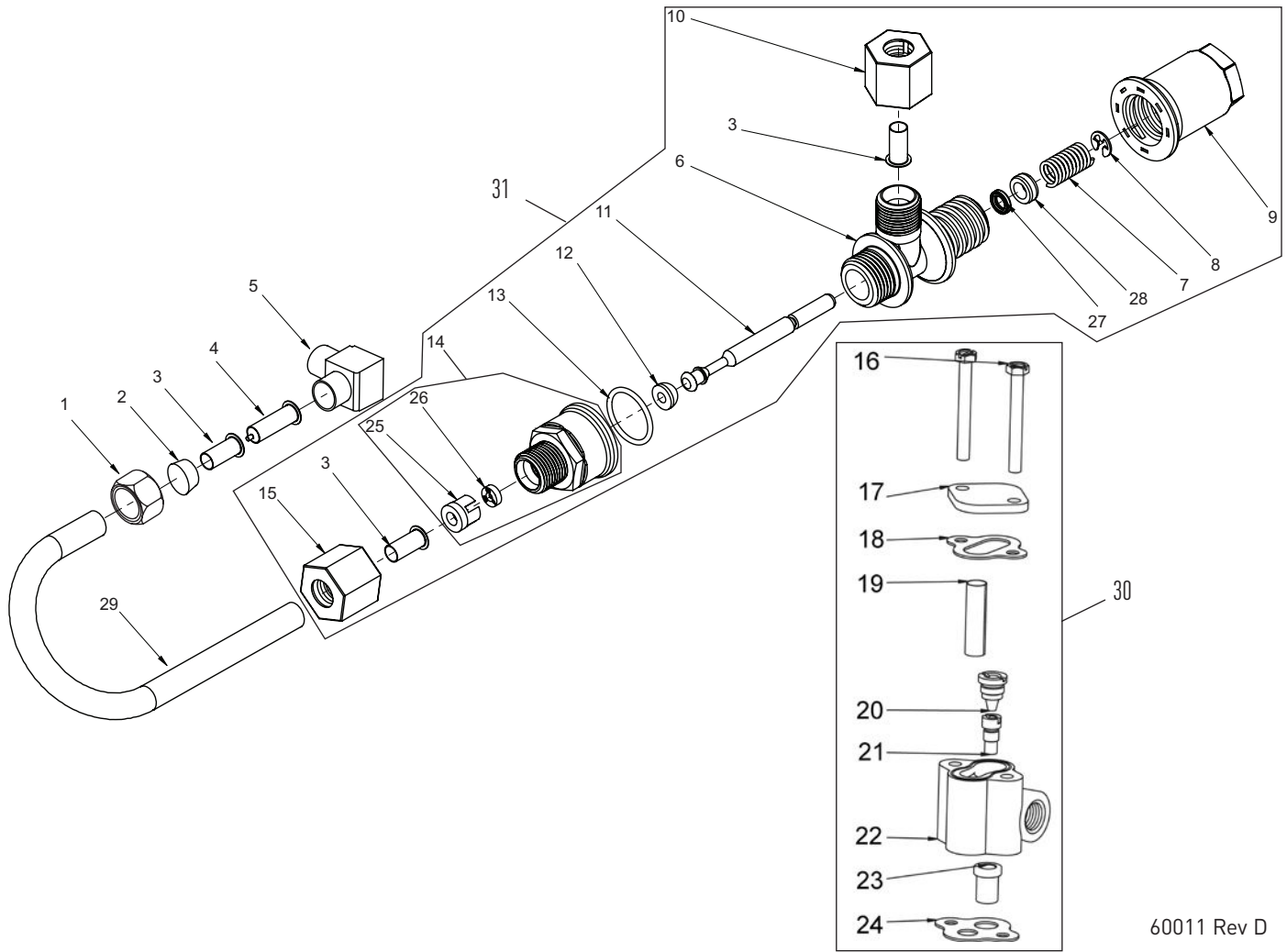

60011 Rev D

Item No.	QTY	Part No.	Description
1	1	10329	Fitting, Tube, 3/8 Nut, Brass
2	1	10330	Fitting, Sleeve, 3/8 Celcon
3	3	10332	Fitting, Insert, 3/8
4	1	12767	Screen, Brine
5	1	10328	Fitting, Elbow, 90 Deg 1/4 NPT x 3/8T
6	1	17884	Brine Valve Body Assy, 1650
7	1	10249	Spring, Brine Valve
8	1	10250	Ring, Retaining
9	1	17906	Guide, Brine Valve Stem
10	1	19625	Nut Assy, 3/8-inch, Plastic
11	1	12552-02	Brine Valve Stem, 1600
12	1	12626	Seat, Brine Valve
13	1	16924	O-ring, -018
14**	1	60010-25	BLFC, 1650, .25 GPM, Plastic
	1	60010-50	BLFC, 1650, .50 GPM, Plastic
	1	60010-100	BLFC, 1650, 1.0 GPM, Plastic
15	1	19625	Nut Assy, 3/8-inch, Plastic
16	2	10692	Screw, Slot Hex Hd, 10 - 24X 18-8 Stainless Steel

Item No.	QTY	Part No.	Description
17	1	11893	Cap, Injector, Stainless Steel
18	1	10229	Gasket, Injector Cap, 1600
19	1	10227	Screen, Injector
20	1	10913-000	Nozzle, Injector, #000, Brown
		10913-00	Nozzle, Injector, #00, Violet
		10913-0	Nozzle, Injector, #0, Red
		10913-1	Nozzle, Injector, #1, White
		10913-2	Nozzle, Injector, #2, Blue
		10913-3	Nozzle, Injector, #3, Yellow
		10913-4	Nozzle, Injector, #4, Green
		12973-0	Nozzle, Injector, #0, PVC Grey
		12973-1	Nozzle, Injector, #1, PVC Grey
		12973-2	Nozzle, Injector, #2, PVC Grey
		12973-3	Nozzle, Injector, #3, PVC Grey
		12973-4	Nozzle, Injector, #4, PVC Grey

1650 BRINE SYSTEM ASSEMBLY *CONTINUED*

Item No.	QTY	Part No.	Description	Item No.	QTY	Part No.	Description
		10225-0	Nozzle, Injector, #0, Stainless Steel	24	1	14805	Gasket, Injector Body, 1600/1700
		10225-1	Nozzle, Injector, #1, Stainless Steel	25	1	12098	Retainer, Flow Control
		10225-2	Nozzle, Injector, #2, Stainless Steel	26	1	12095	Washer, Flow Control .50 GPM
		10225-3	Nozzle, Injector, #3, Stainless Steel		1	12094	Washer, Flow Control .25 GPM
		10225-4	Nozzle, Injector, #4, Stainless Steel		1	12097	Washer, Flow Control 1.0 GPM
21	1	10914-000	Throat, Injector, #000, Brown	27	1	12550	Quad Ring -009
		10914-00	Throat, Injector, #00, Violet		1	12550-01	Quad Ring -009 560CD
		10914-0	Throat, Injector, #0, Red	28	1	17908	Sleeve, Brine Valve Stem
		10914-1	Throat, Injector, #1, White	29	1	16508-01	Tube, Brine Valve, 2850/1600
		10914-2	Throat, Injector, #2, Blue		1	40027	Tube, Brine Valve, 2510
		10914-3	Throat, Injector, #3, Yellow		1	42184	Tube, Brine Valve, 2850s
		10914-4	Throat, Injector, #4, Green		1	12774	Tube, Brine Valve, 1500
		12974-0	Throat, Injector, #0, PVC Grey		1	15221	Tube, Brine Valve, 2750
		12974-1	Throat, Injector, #1, PVC Grey		1	41683*	Tube, Brine Valve, UF, 1600/1650
		12974-2	Throat, Injector, #2, PVC Grey	30		60480-01	Injector Assy, 1600, #1 Plastic
		12974-3	Throat, Injector, #3, PVC Grey			60480-02	Injector Assy, 1600, #2 Plastic
		12974-4	Throat, Injector, #4, PVC Grey			60480-03	Injector Assy, 1600, #3 Plastic
		10226-0	Throat, Injector, #0, Stainless Steel			60480-04	Injector Assy, 1600, #4 Plastic
		10226-1	Throat, Injector, #1, Stainless Steel			60481-21	Injector Assy, 1600, #1, S.S. Brass
		10226-2	Throat, Injector, #2, Stainless Steel			60481-22	Injector Assy, 1600, #2, S.S. Brass
		10226-3	Throat, Injector, #3, Stainless Steel			60481-23	Injector Assy, 1600, #3, S.S. Brass
		10226-4	Throat, Injector, #4, Stainless Steel			60080-11	Injector Assy, 1600, #1, PVC
22	1	17776	Body, Injector, 1600			60080-12	Injector Assy, 1600, #2, PVC
	1	17776-02*	Body, Injector, 1600 Upflow			60080-14	Injector Assy, 1600, #4, PVC
23	1	16221	Dispenser, Air	31		60011-010	Brine Valve, 1650, 0.25 gpm
						60011-020	Brine Valve, 1650, 0.50 gpm
						60011-030	Brine Valve, 1650, 1.0 gpm

*Upflow Only

**Item 14 includes Items 25 and 26

1700 BRINE SYSTEM ASSEMBLY

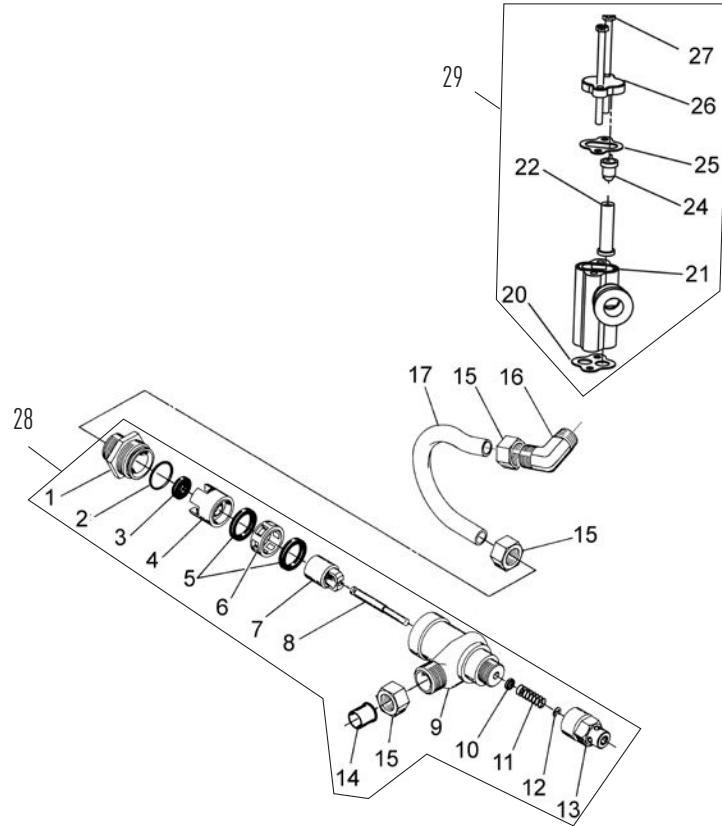

60034 Rev D

1700 BRINE SYSTEM ASSEMBLY CONTINUED

Item No.	QTY	Part No.	Description
1	1	14792	Plug, End, Brine Valve
2	1	13201	Quad Ring, -020
3	1	12085	Washer, Flow, 1.2 GPM
	1	12086	Washer, Flow, 1.5 GPM
	1	12087	Washer, Flow, 2.0 GPM
	1	12088	Washer, Flow, 2.4 GPM
	1	12089	Washer, Flow, 3.0 GPM
	1	12090	Washer, Flow, 3.5 GPM
	1	12091	Washer, Flow, 4.0 GPM
	1	12092	Washer, Flow, 5.0 GPM
4	1	14785	Retainer, Flow Control
5	3	14811	O-ring, -210, 560CD, Brine
6	1	14798	Spacer, 1700, Brine
7	1	14795	Piston, Brine Valve
8	1	14797	Brine Valve Stem
9	1	14790	Brine Valve Body
10	1	12550	Quad Ring, -009
11	1	15310	Spring, Brine Valve
12	1	10250	Retaining Ring
13	1	15517	Guide, Stem
14	1	15415	Fitting, Insert, 1/2-inch, Tube
15	3	15414	Nut, 2900, w/Sleeve
16	1	15413	Fitting, Elbow, Male, 1/2T x 3/8 NPT
17	1	15416	Tube, Brine, 2900/2750
	1	16460	Tube, Brine, 2850/2900s
	1	41447*	Tube, Brine, 2900s, U/F
	1	42183	Tube, Brine, 1700, 2850s
20	1	14805	Gasket, Injector Body 1600/1700
21	1	17777	Body, Injector, 1700
	1	17777-02*	Body, Injector, 1700 U/F
22	1	14802-03c	Throat, Injector, #3c, Yellow
		14802-04c	Throat, Injector, #4c, Green
		14802-05c	Throat, Injector, #5c, White
		14802-06c	Throat, Injector, #6c, Red
24		14801-03c	Nozzle, Injector, #3c, Yellow
		14801-04c	Nozzle, Injector, # 4c, Green
		14801-05c	Nozzle, Injector, # 5c, White
		14801-06c	Nozzle, Injector, # 6c, Red
25	1	10229	Gasket, Injector Cap, 1600
26	1	11893	Cap, Injector, Stainless Steel
	1	10228	Cap, Injector

Item No.	QTY	Part No.	Description
27	2	14804	Screw, Hex Hd Mach, 10 - 24 x 2-3/4-inch 18-8 Stainless Steel
28	1	60034-00	Brine Valve, 1700, Blank
		60034-10	Brine Valve, 1700, 1.0 gpm
		60034-12	Brine Valve, 1700, 1.2 gpm
		60034-15	Brine Valve, 1700, 1.5 gpm
		60034-20	Brine Valve, 1700, 2.0 gpm
		60034-24	Brine Valve, 1700, 2.4 gpm
		60034-30	Brine Valve, 1700, 3.0 gpm
		60034-40	Brine Valve, 1700, 4.0 gpm
		60034-50	Brine Valve, 1700, 5.0 gpm
29	1	60381-03	Injector Assy, 1700, #3c, Complete
		60381-04	Injector Assy, 1700, #4c, Complete
		60381-05	Injector Assy, 1700, #5c, Complete
		60381-06	Injector Assy, 1700, #6c, Complete

Not Shown:

1	16974	Fitting, Plastic, Female, 3/4 x 3/4 Slip
1	17996	Dispenser, Air, Injector

*Upflow Only

NOTE: Item number 26 (11893) is used on injector sizes 2 through 5C. Part number 10228 is used on injector sizes 6C.

1710 BRINE SYSTEM ASSEMBLY

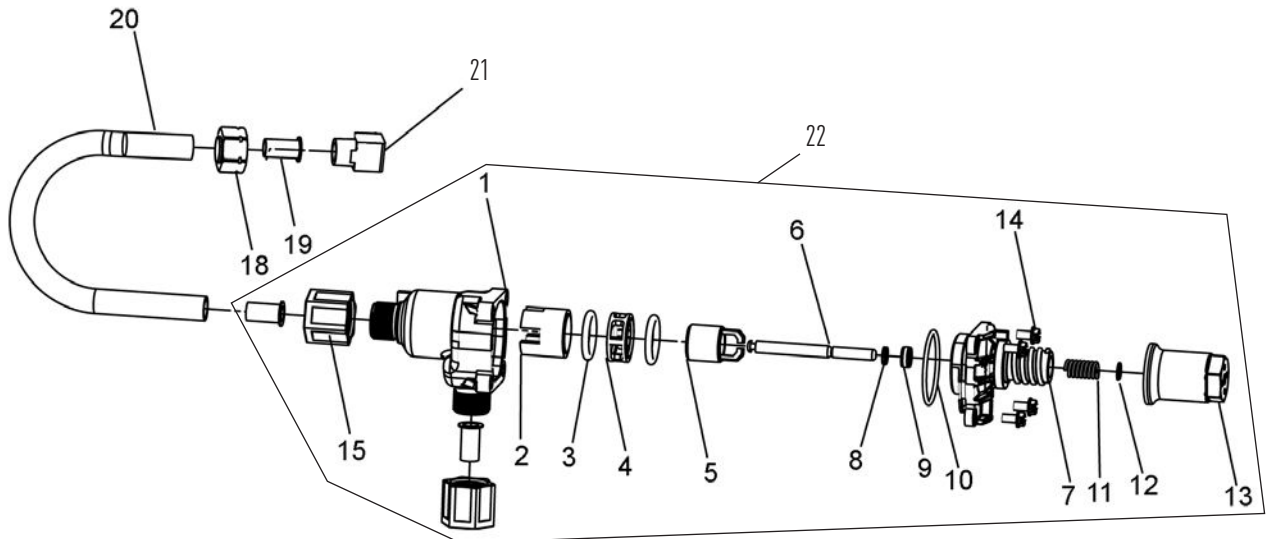

60604 Rev F

Item No.	QTY	Part No.	Description
1	1	41202	Brine Valve, 1700, Plastic, Top
2	1	14785-01	Retainer, Flow Control
3	1	14811	O-Ring, -210, 560CD, Brine
4	1	14798	Spacer, 1700, Brine
5	1	14795	Piston, Brine Valve
6	1	41203	Stem, Brine, 1710, Plastic, 2900
7	1	41201	Brine Valve, 1700, Plastic, Bottom
8	5	17908	Sleeve, Brine Valve Stem
9	1	12550	Quad Ring, -009
10	3	41547	O-Ring, 2mmx35mm
11	2	15310	Spring, Brine Valve
12	2	10250	Ring, Retaining
13	1	17906	Guide, Brine Valve Stem
14	2	14202-01	Screw, Hex Wsh Mach, 8-32 X 5/16
15	2	41056	Nut Assembly, 1/2-inch Plastic
18	1	15414	Nut, 2900, w/Sleeve
19	1	15415	Fitting, Insert, 1/2-inch, Tube
20	1	16460	Tube, Brine, 2850, 2900s
	1	42183	Tube, Brine, 1700/2850s
	1	15416	Tube, Brine, 2900/2750
	1	41447*	Tube, Brine, 2900s U/F

Item No.	QTY	Part No.	Description
21	1	15413	Fitting, Elbow, Male, 1/2T X 3/8NPT
22		60605-00	Brine Valve, 1710, 2750, Blank
		60605-10	Brine Valve, 1710, 2750, 1.0 gpm
		60605-12	Brine Valve, 1710, 2750, 1.2 gpm
		60605-15	Brine Valve, 1710, 2750, 1.5 gpm
		60605-20	Brine Valve, 1710, 2750, 2.0 gpm
		60605-24	Brine Valve, 1710, 2750, 2.4 gpm
		60605-30	Brine Valve, 1710, 2750, 3.0 gpm
		60605-40	Brine Valve, 1710, 2750, 4.0 gpm
		60605-50	Brine Valve, 1710, 2750, 5.0 gpm

Not Shown

1		19151	Washer, Flow, 1.0 gpm
1		17996	Disperser, Air, Injector
1		414193-00	Label, Blank, BLFC, 1710

1600 SERVICE VALVE OPERATOR ASSEMBLY (OLD STYLE)

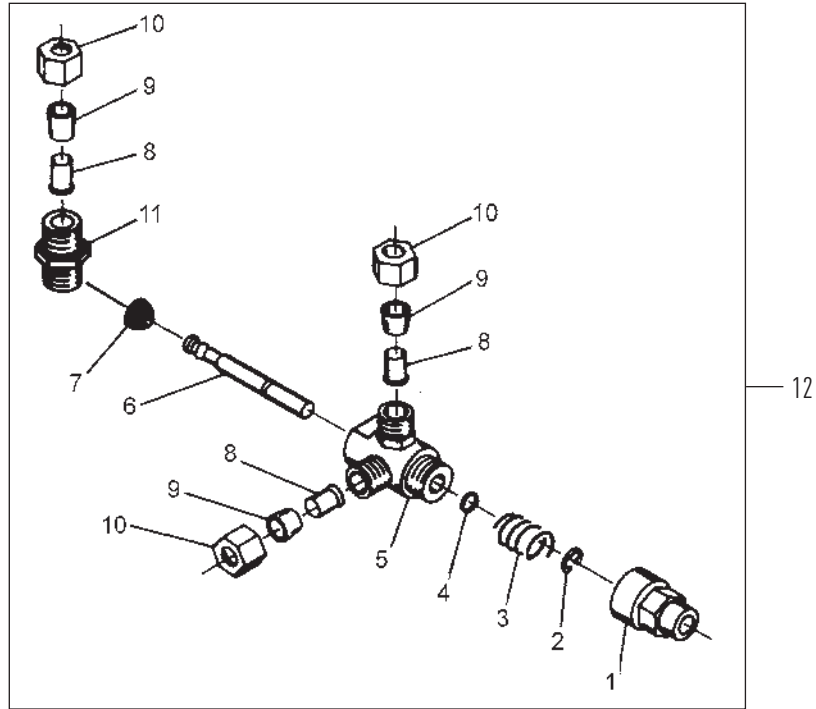

60150 Rev A

Item No.	QTY	Part No.	Description
1	1	11749	Guide, Brine Valve Stem
2	1	10250	Ring, Retaining
3	1	10249	Spring, Brine Valve
4	1	12550	Quad Ring, -009
5	1	10785	SVO Body Assy Brass Valves
6	1	12552-02	Brine Valve Stem, 1600, w/Seat
7	1	12626	Seat, Brine Valve
8	3	10332	Fitting, Insert, 3/8
9	3	10330	Fitting, Sleeve, 3/8 Celcon
10	3	10329	Fitting, Tube, 3/8 Nut, Brass
11	1	10331	Fitting, Compression, 1/4-inch x 3/8-inch
12	1	60150	Service Valve Operator, Assy, 1600, Old Style, Complete

1-INCH BRASS METER ASSEMBLY

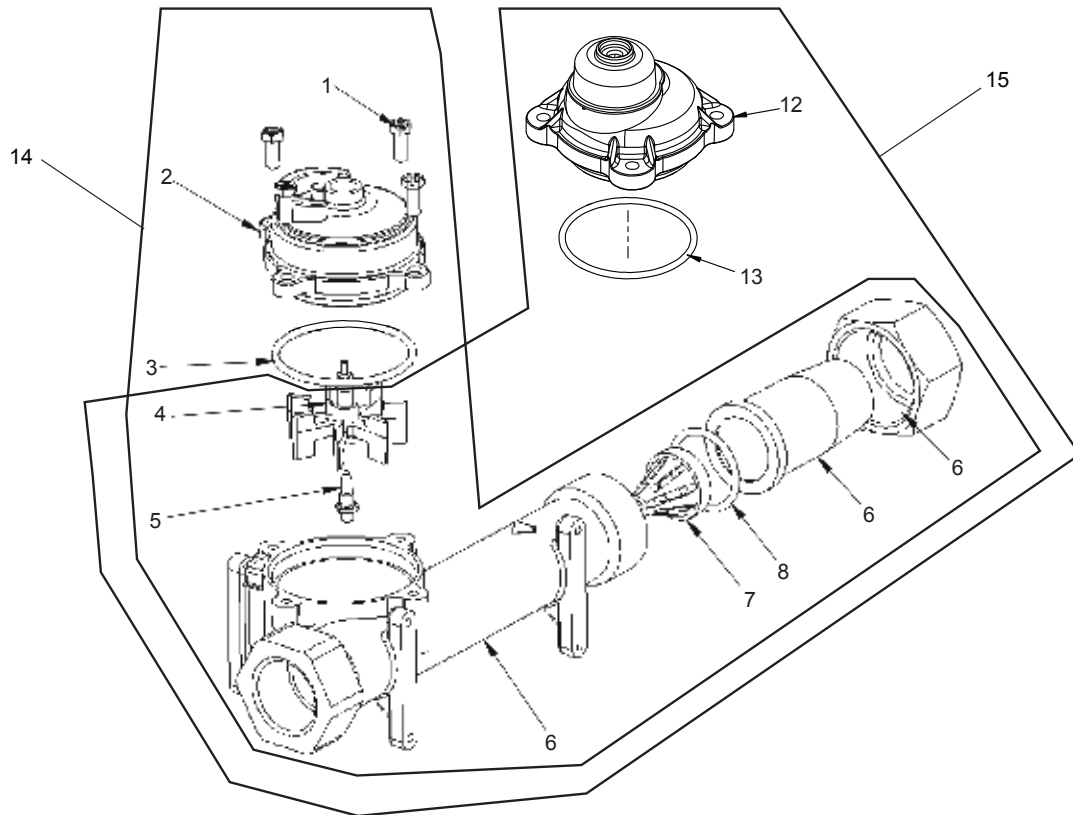

Item No.	QTY	Part No.	Description
1	4	12112	Screw, Slotted Hex Head, #10 - 24 x .50
2	1	14038	Cap, Meter, STD Range, Plastic
3	1	13847	O-ring, -137
4	1	13509	Impeller, Meter
	1	13509-01	Impeller, Celcon, Hot Water
5	1	13882	Post, Meter Impeller
6	1	14959	Body, Meter, 27550
	1	60628NP	Meter Assy, 1-inch, NP
		14959	Body, Meter, 2750
		14961	Fitting, Nipple, 1-inch, Quick Connect
		14962	Nut, 1-inch Meter, Quick Connect
7	1	14960	Flow Straightener
8	1	13287	O-ring, 123
12	1	15150	Meter Cap Assy, Ext, Range, Plastic
13	1	13847	O-ring, -137
14		60391	Meter Assy, 1-inch, NPT, STD Range, Brass, Paddlewheel
		60391NP	Meter Assy, 1-inch Inline, NPT, STD Nickel Plated, Paddlewheel
		60391HW	Meter Assy, 1-inch Inline, NPT, STD, Brass, Hot Water, Paddlewheel

Item No.	QTY	Part No.	Description
15		60392	Meter Assy, 1-inch Inline, NPT EXT Range
		60392NP	Meter Assy, 1-inch Inline, NPT, EXT Brass Body, Nickel Plated, Paddlewheel

Not Shown

1		15218	Meter Cap Assy, STD Range, Brass, Hot Water
1		15237	Meter Cap Assy, EXT Range, Brass, Hot Water

1-1/2 INCH BRASS METER ASSEMBLY

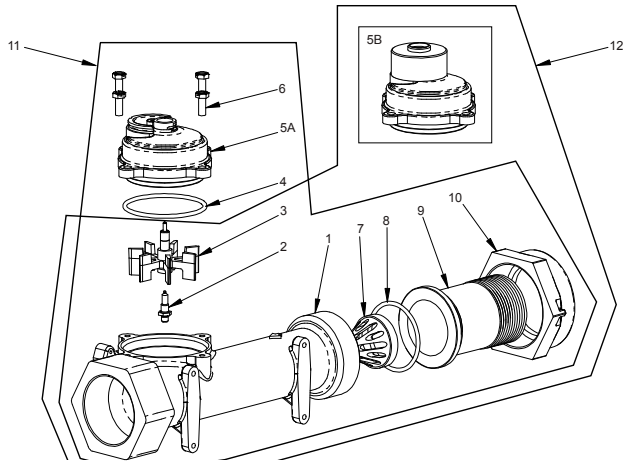

Item No.	QTY	Part No.	Description
1	1	17569	Body, Meter, 2850/9500
2	1	13882	Post, Meter Impeller
3	1	13509	Impeller, Meter
	1	13509-01	Impeller, Celcon, Hot Water
4	1	13847	O-Ring, -137, Std/560CD, Meter
5A	1	14038	Meter Cap Assy, STD Range, Plastic
5B	1	15150	Meter Cap Assy, Ext Range, Plastic
6	4	12112	Screw, Hex Hd Mach, 10-24 x 1/2 18-8 Stainless Steel
7	1	17542	Flow Straightener, 1-1/2 inch
8	1	12733	O-Ring, -132
9	1	17544	Fitting, 1-1/2 inch Quick Connector
10	1	17543	Nut, 1-1/2 inch, Q/C
11		60610-01	Meter Assy, 1-1/2 inch, NPT, STD, Brass, Paddlewheel
		60610-01NP	Meter Assy, 1-1/2 inch Inline, NPT, STD Brass Body, Nickel Plated, Paddlewheel
		60610-01HW	Meter Assy, 1-1/2 inch Inline, NPT, STD Brass, Hot Water, Paddlewheel
		60610-21	Meter Assy, 1-1/2 inch, BSP, STD, Brass, Paddlewheel
		60610-21NP	Meter Assy, 1-1/2 inch Inline, BSP, STD, Brass Body, Nickel Plated, Paddlewheel
		60611-01	Meter Assy, 1-1/2 inch Inline, NPT, STD, Brass Body, Paddlewheel, Sleeve to 1-inch
		60611-01NP	Meter Assy, 1-1/2 inch Inline, NPT, STD Nickel Plated, Paddlewheel, Sleeve to 1-inch

Item No.	QTY	Part No.	Description
		60611-23	Meter Assy, 1-1/2 inch Inline, BSP, STD, Paddlewheel, Sleeve to 1-inch
		60611-23NP	Meter Assy, 1-1/2 inch Inline, BSP/MET STD, Nickel Plated, Paddlewheel, 1-inch Sleeve
12		60610-02	Meter Assy, 1-1/2 inch, NPT, STD, Brass Paddlewheel
		60610-02NP	Meter Assy, 1-1/2 inch Inline, NPT, EXT Nickel Plate, Paddlewheel
		60610-02HW	Meter Assy, 1-1/2 inch Inline, NPT, EXT Brass, Hot Water, Paddlewheel
		60610-22	Meter Assy, 1-1/2 inch, BSP, EXT, Brass, Paddlewheel
		60610-22NP	Meter Assy, 1-1/2 inch Inline, BSP EXT, Brass Body, Nickel Plate, Paddlewheel
		60611-02	Meter Assy, 1-1/2 inch Inline, NPT, EXT Brass Body, Paddlewheel, Sleeve to 1-inch
		60611-02NP	Meter Assy, 1-1/2 inch Inline, NPT, EXT Nickel Plated, Paddlewheel, Sleeve to 1-inch
		60611-22	Meter Assy, 1-1/2 inch Inline, BSP, EXT Brass Body, Paddlewheel, Sleeve to 1-inch
		60611-22NP	Meter Assy, 1-1/2 inch Inline, BSP, EXT, Nickel, Paddlewheel, Sleeve to 1-inch

Not Shown

1		17790	Sleeve, Meter, 1 1/2 inch x 1-inch
1		15218	Meter Cap Assy, STD Range, Brass, Hot Water
1		15237	Meter Cap Assy, EXT Range, Brass, Hot Water

1-1/2 INCH STAINLESS STEEL METER ASSEMBLY

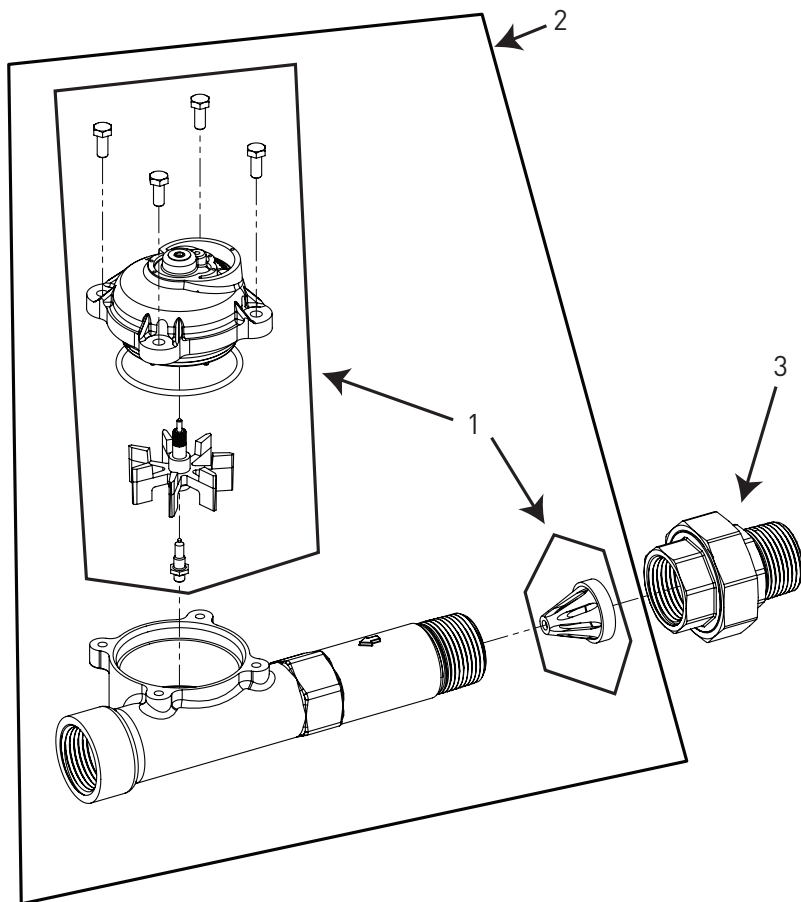

Item No.	QTY	Part No.	Description
1	1	62049-01	Service Kit, 1 inch & 1-1/2 inch Meter, Standard Range
1	1	62049-02	Service Kit, 1 inch & 1-1/2 inch Meter, Extended Range
2	1	61933-10	Meter Assy, 1-1/2 inch, Inline, Stainless Steel, NPT, Standard Range
1	1	61933-11	Meter Assy, 1-1/2 inch, Inline, Stainless Steel, NPT, Extended Range
1	1	61933-20	Meter Assy, 1-1/2 inch, Inline, Stainless Steel, BSP, Standard Range
1	1	61933-21	Meter Assy, 1-1/2 inch, Inline, Stainless Steel, BSP, Extended Range
3	1	44024	Union, 1-1/2 inch, NPT (Optional on models with electronic controls)
1	1	44025	Union, 1-1/2 inch, BSP (Optional on models with electronic controls)

⚠ IMPORTANT: For valves equipped with electromechanical timers and stainless steel meters, refer to the Meter Dome and Union Orientation section.

Not Shown (optional)

1	1	62072	Meter Sleeve, 1-1/2 inch to 1 inch (optional)
---	---	-------	---

2300 SAFETY BRINE VALVE

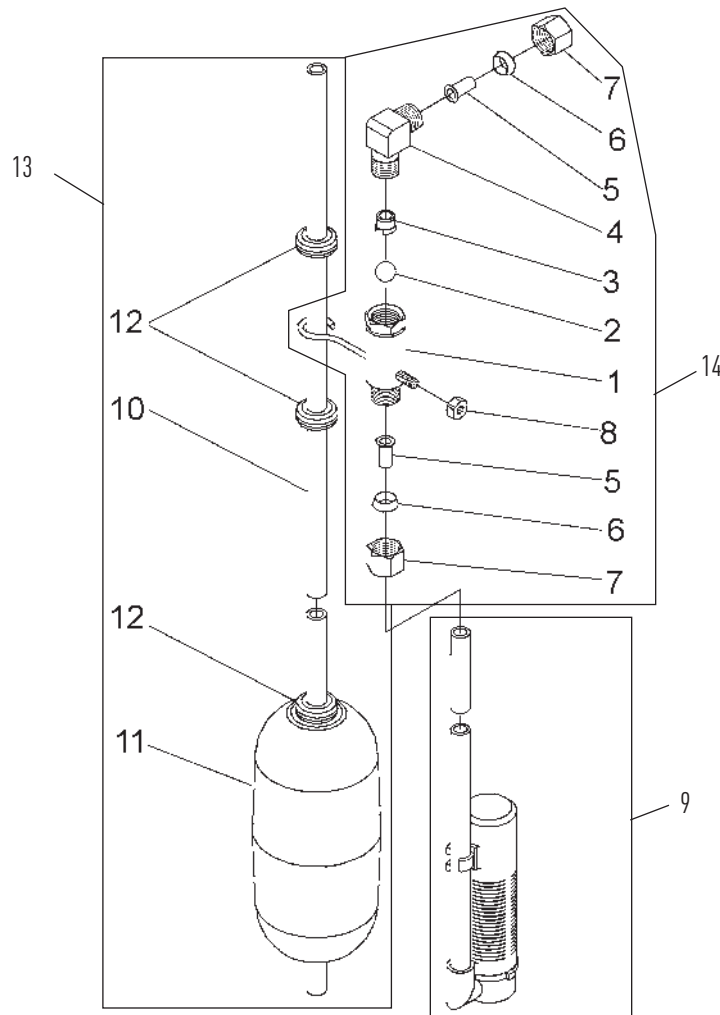

60027 Rev D

Item No.	QTY	Part No.	Description	Item No.	QTY	Part No.	Description
1	1	60027-00	Safety Brine Valve, 2300, Less Elbow			60002-34	Air Check, #500, 34 inches Long
2	1	10138	Ball, 3/8-inch, Brass			60002-36	Air Check, #500, 36 inches Long
3	1	11566	Ball Stop, Slow Fill			60002-48	Air Check, #500, 48 inches Long
4	1	10328	Fitting, Elbow, 90 Deg. 1/4 NPT x 3/8 Tube			60002-26.25	Air Check, #500, 26.25 inches Long
5	1	10332	Fitting, Insert, 3/8			60002-33.25	Air Check, #500, 33.25 inches Long
6	1	10330	Fitting, Sleeve, 3/8 Celcon	10	1	10149	Rod, Float, 30-inch
7	1	10329	Fitting, Tube, 3/8 Nut, Brass	11	1	10700	Float Assy, White
8	1	10186	Nut, Hex, 10-32	12	3	10150	Grommet, .30 Dia
9	1	60002-10	Air Check, #500, American Hydro	13	1	60028-30	Float Assy, 2300, 30-inch White
		60002-11.38	Air Check, #500, 11.38 inches Long	14	1	60027-FFA	Safety Brine Valve, 2300, Fitting Facing Arm
		60002-24	Air Check, #500, 24 inches Long	1	1	60027-FFS	Safety Brine Valve, 2300 Fitting Facing Stud
		60002-27	Air Check, #500, 27 inches Long				
		60002-32	Air Check, #500, 32 inches Long				

2310 SAFETY BRINE VALVE

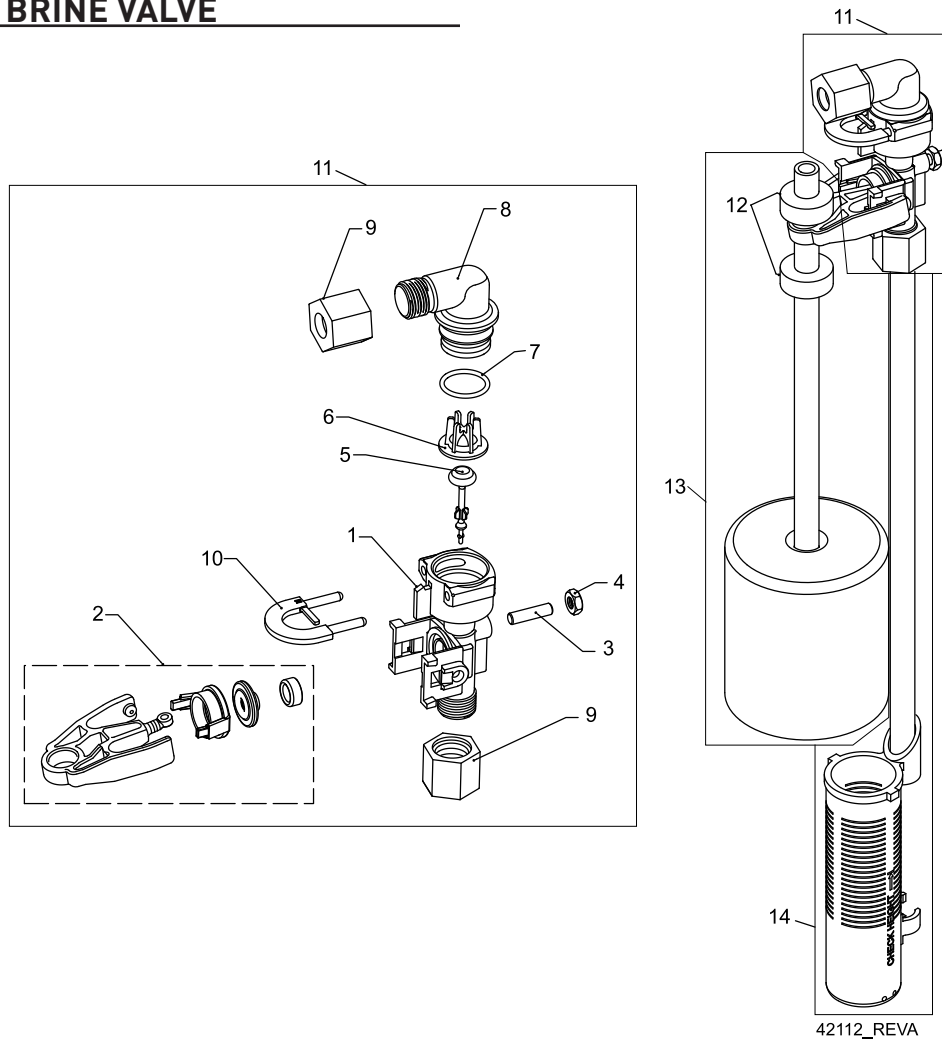

42112_REVA

Item No.	QTY	Part No.	Description
1	1	19645	Body, Safety Brine Valve, 2310
2	1	19803	Safety Brine Valve Assy
3	1	19804	Screw, Sckt Hd, Set, 10-24 x .75
4	1	19805	Nut, Hex, 10-24, Nylon Black
5	1	19652-01	Poppet Assy, SBV w/O-ring
6	1	19649	Flow Dispenser
7	1	11183	O-ring, -017
8	1	19647	Elbow, Safety Brine Valve
9	2	19625	Nut Assy, 3/8-inch Plastic
10	1	18312	Retainer, Drain
11	1	60014	Safety Brine Valve Assy, 2310
12	2	10150	Grommet, .30 Dia
13	1	60068-8.06	Float Assy, 2310, w/8.06-inch Rod
		60068-10.5	Float Assy, 2310, w/10.5-inch Rod
		60068-11.5	Float Assy, 2310, w/11.5-inch Rod

Item No.	QTY	Part No.	Description
		60068-20	Float Assy, 2310, w/20-inch Rod
		60068-30	Float Assy, 2310, w/30-inch Rod
14	1	60002-10	Air Check, #500, American Hydro
		60002-11.38	Air Check, #500, 11.38 inches Long
		60002-24	Air Check, #500, 24 inches Long
		60002-27	Air Check, #500, 27 inches Long
		60002-32	Air Check, #500, 32 inches Long
		60002-34	Air Check, #500, 34 inches Long
		60002-36	Air Check, #500, 36 inches Long
		60002-48	Air Check, #500, 48 inches Long
		60002-26.25	Air Check, #500, 26.25 inches Long
		60002-33.25	Air Check, #500, 33.25 inches Long

2350 SAFETY BRINE VALVE

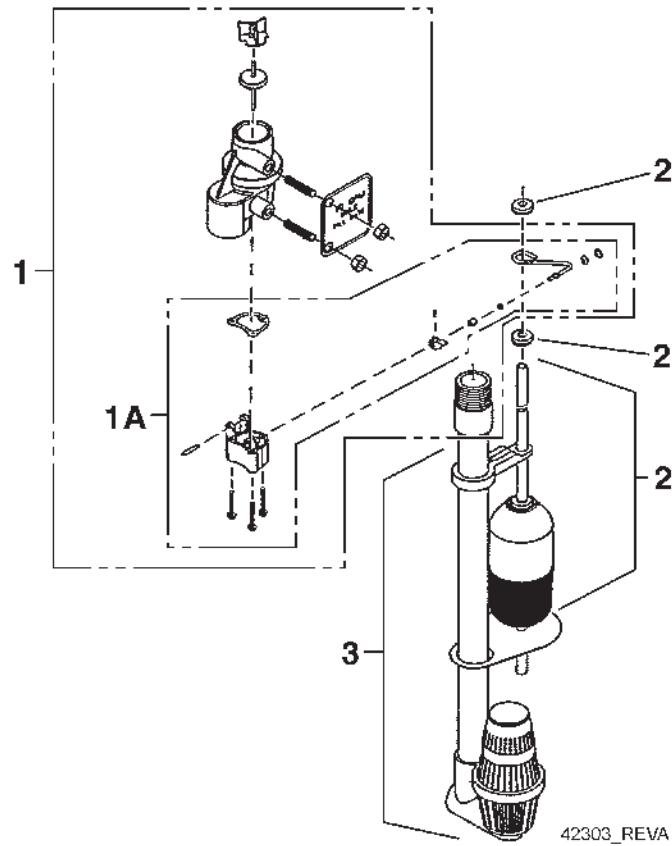

Item No.	QTY	Part No.	Description
1	1	60038	Safety Brine Valve, 2350
1A	1	61024	Actuator Assy, 2350 Brine
2	1	60028-30	Float Assy, 2350, 30-inch Wht
	1	60026-30SAN	Float Assy, 2350, 30-inch Hot Water
3	1	60009-00	Air Check, #900, Commercial Less Fittings
	1	60009-01	Air Check, #900, Commercial, Hot Water Less Fittings

Not Shown

	1	18603	Fitting Assy, 900 Air Check 2350
	1	18602	Fitting Assy, 900 Air Check

SEAL & SPACER TOOLS & REPLACEMENT

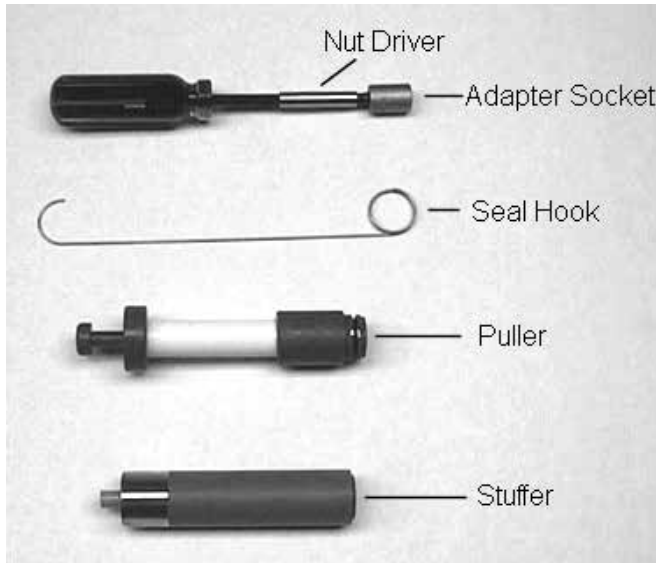

Figure 8

Tools Used in the Seal and Spacer Replacement

Description	Part No.
Nut Driver	12664
Socket Adapter.....	16906
Socket 7/16-inch.....	12665
Seal Hook	12874
Puller	13061, 1500/2510/5600/4650
.....	17623, 2850/9500
.....	12682, 2900/3180
Stuffer	11098, 1500/2510/2750
.....	12763, 5600/9000/9100/4650
.....	12683, 2100/3150
.....	16516, 2850/9500

NOTE: Photos shown are for reference only for replacing the seal and spacer. Actual valve may be different.

1. Turn off water supply to valve. Next, cycle valve to backwash position, then to service. Now remove electrical plug from outlet.
2. Remove control box cover.
3. Disconnect the brine line from the injector housing to the brine valve (if your unit has timed brine tank fill).
4. Remove the two capscrews that hold the back plate to the valve.
5. Grasp the back plate on both sides and slowly pull end plug and piston assembly out of the valve body (see "Figure 9") and lay aside.

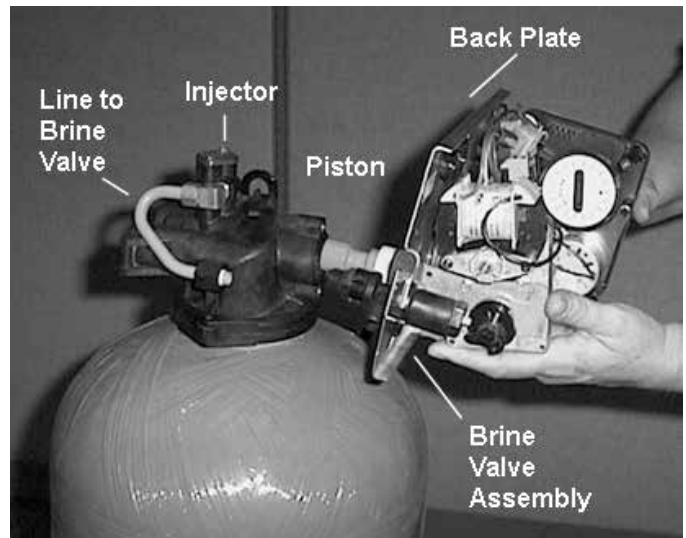

Figure 9

6. Remove the seal first using the wire hook with the finger loop (see "Figure 10").

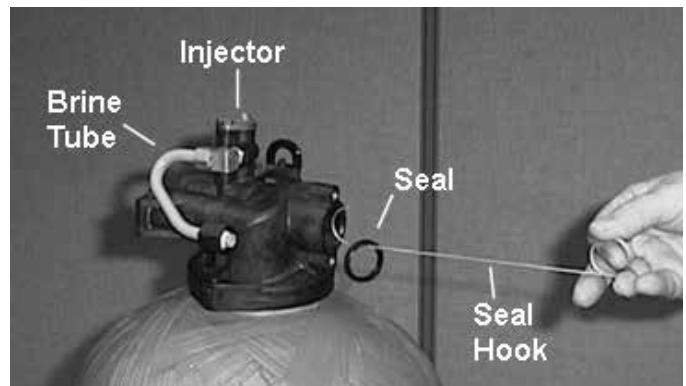

Figure 10

7. The spacer tool (use only for removing the spacers) has three retractable pins, retained by a rubber ring, at one end. They are retracted or pushed out by pulling or pushing the center button the opposite end.
8. Insert the pin end of the spacer tool into the valve body with the pins retracted (button pulled back). Push the tool tight against the spacer and push the button in. When the button is pushed in, the pins are pushed out to engage the 1/4 dia. holes in the spacer. Remove the tool from the valve body. The spacer will be on the end. Pull the center button back, the pins will be retracted and the spacer can be removed from the spacer tool.

SEAL & SPACER TOOLS & REPLACEMENT

CONTINUED

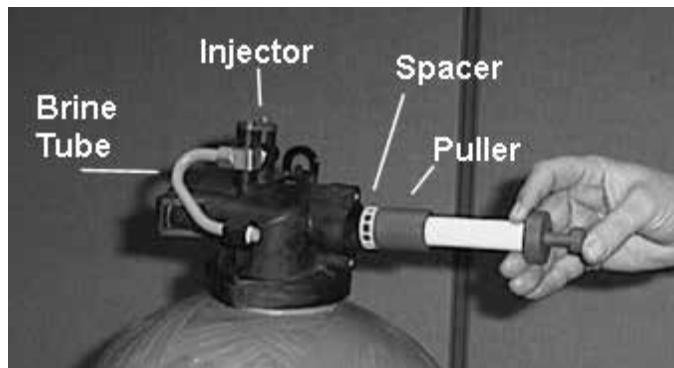

Figure 11

9. Alternately remove the remaining seals and spacers in accordance with steps No. 6 and 8.
10. The last or end spacer does not have any holes for the pins of the spacer tool to engage, therefore if the end spacer does not come out on the first try, try again using the wire hook with the finger loop.
11. To replace seals, spacers and end ring, use special tool with the brass sleeve on one end. This is a double-purpose tool. The male end acts as a pilot to hold the spacers as they are pushed into the valve body and the brass female end is used to insert the seals into the valve body.

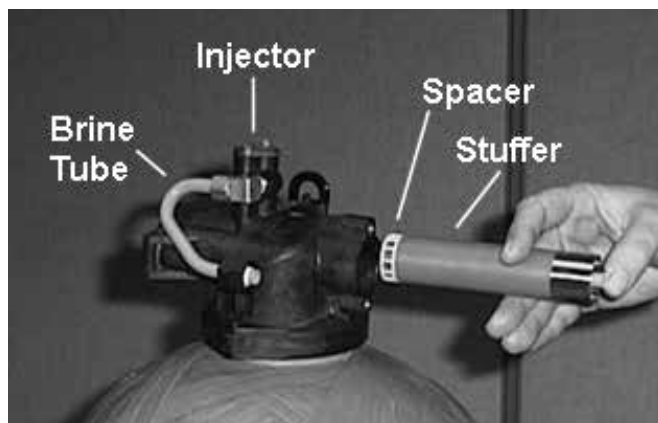

Figure 12

12. To restuff a valve body, first take the end ring (the plastic or brass ring without holes), then with your thumb press the button on the brass sleeve end. The large dia. inner portion is now exposed (see Figure 8). Place the end ring on this pilot with the lip on the end ring facing the tool. Push the tool into the valve body bore until it bottoms. While the tool is in the valve body, take a seal and press it into the inside diameter of the exposed brass female end.
13. Remove the tool, turn it end for end and insert it into the valve body bore. While holding the large dia. of the tool, slide it all the way into the valve body bore until it bottoms. Then push the center button to push the seal of the tool and leave it in place in the valve body.
14. Remove the tool from the valve body and push the center on the brass female end to expose the pilot on the opposite end. Place a spacer on this end and insert the spacer and tool into the valve.

GENERAL SERVICE HINTS FOR METER CONTROL

Problem: Softener delivers hard water

Reason: Reserve capacity has been exceeded.

Correction: Check salt dosage requirements and reset program wheel to provide additional reserve.

Reason: Program wheel is not rotating with meter output.

Correction: Pull cable out of meter cover and rotate manually. Program wheel must move without binding and clutch must give positive clicks when program wheel strikes regeneration stop. If it does not, replace timer.

Reason: Meter is not measuring flow.

Correction: Check meter with meter checker.

TROUBLESHOOTING

Problem	Cause	Correction
Water conditioner fails to regenerate.	Electrical service to unit has been interrupted	Assure permanent electrical service (check fuse, plug, pull chain, or switch)
	Timer is defective.	Replace timer.
	Power failure.	Reset time of day.
Hard water.	By-pass valve is open.	Close by-pass valve.
	No salt is in brine tank.	Add salt to brine tank and maintain salt level above water level.
	Injector screen plugged.	Clean injector screen.
	Insufficient water flowing into brine tank.	Check brine tank fill time and clean brine line flow control if plugged.
	Hot water tank hardness.	Repeated flushings of the hot water tank is required.
	Leak at distributor tube.	Make sure distributor tube is not cracked. Check o-ring and tube pilot.
	Internal valve leak.	Replace seals and spacers and/or piston.
Unit used too much salt.	Improper salt setting.	Check salt usage and salt setting.
	Excessive water in brine tank.	See "Excessive water in brine tank".
Loss of water pressure.	Iron buildup in line to water conditioner.	Clean line to water conditioner.
	Iron buildup in water conditioner.	Clean control and add mineral cleaner to mineral bed. Increase frequency of regeneration.
	Inlet of control plugged due to foreign material broken loose from pipes by recent work done on plumbing system.	Remove piston and clean control.
Loss of mineral through drain line.	Air in water system.	Assure that well system has proper air eliminator control. Check for dry well condition.
	Improperly sized drain line flow control.	Check for proper drain rate.
Iron in conditioned water.	Fouled mineral bed.	Check backwash, brine draw, and brine tank fill. Increase frequency of regeneration. Increase backwash time.
Excessive water in brine tank.	Plugged drain line flow control.	Clean flow control.
	Plugged injector system.	Clean injector and screen.
	Timer not cycling.	Replace timer.
	Foreign material in brine valve.	Replace brine valve seat and clean valve.
	Foreign material in brine line flow control.	Clean brine line flow control.
Softener fails to draw brine.	Drain line flow control is plugged.	Clean drain line flow control.
	Injector is plugged.	Clean injector
	Injector screen plugged.	Clean screen.
	Line pressure is too low.	Increase line pressure to 20 psi
	Internal control leak	Change seals, spacers, and piston assembly.
	Service adapter did not cycle.	Check drive motor and switches.
Control cycles continuously.	Misadjusted, broken, or shorted switch.	Determine if switch or timer is faulty and replace it, or replace complete power head.
Drain flows continuously.	Valve is not programming correctly.	Check timer program and positioning of control. Replace power head assembly if not positioning properly.
	Foreign material in control.	Remove power head assembly and inspect bore. Remove foreign material and check control in various regeneration positions.
	Internal control leak.	Replace seals and piston assembly.

WATER CONDITIONER FLOW DIAGRAMS

1 Service Position

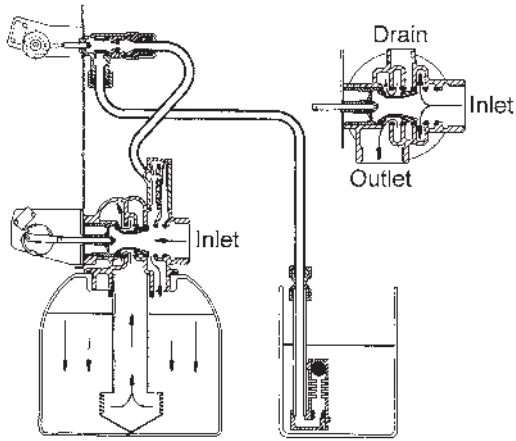

Hard water enters unit at valve inlet and flows down through the mineral in the mineral tank. Conditioned water enters center tube through the bottom distributor, then flows up through the center tube, around the piston, and out the outlet of the valve.

4 Slow Rinse Position

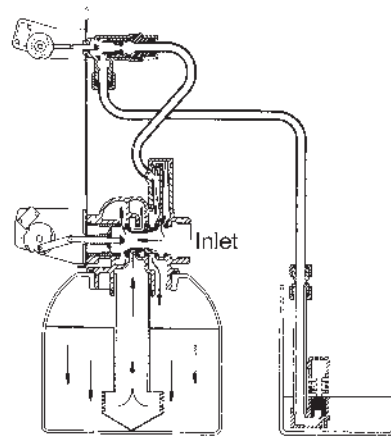

Hard water enters unit at valve inlet, flows up into injector housing and down through nozzle and throat, around the piston, down through mineral, enters center tube through bottom distributor, flows up through center tube, around piston and out through drain line.

2 Backwash Position

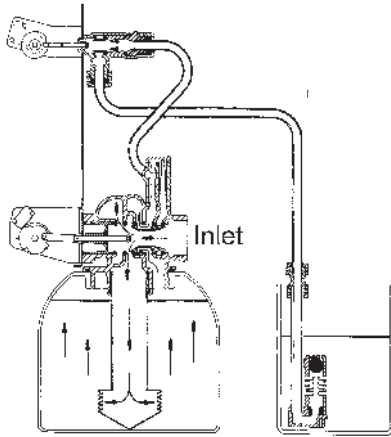

Hard water enters unit at valve inlet, flows through piston, down center tube, through bottom distributor, and up through the mineral, around the piston and out the drain line.

5 Rapid Rinse

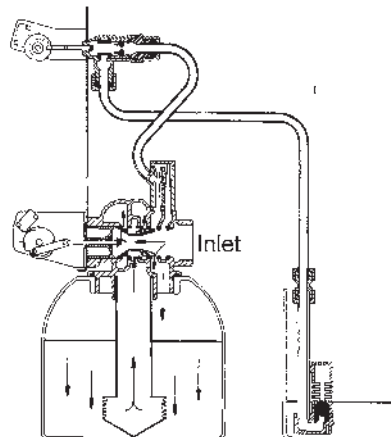

Hard water enters unit at valve inlet, flows directly from inlet down through mineral into center tube bottom distributor and up through center tube, around piston and out through the drain line.

3 Brine Position

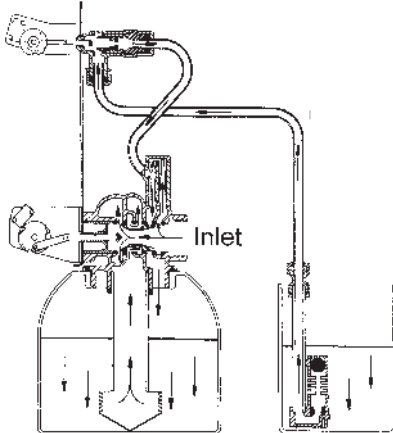

Hard water enters unit at valve inlet, flows up into injector housing and down through nozzle and throat to draw brine from the brine tank, brine flows down through mineral and enters the center tube through bottom distributor and out through the drain line.

6 Brine Tank Refill Position

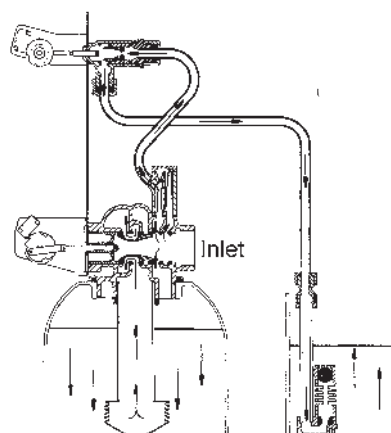

Hard water enters unit at valve inlet, flows up through the injector housing, through the brine valve to refill the brine tank.

FLOW DATA & INJECTOR DRAW RATES

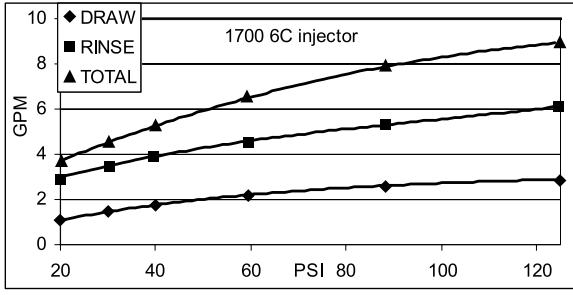
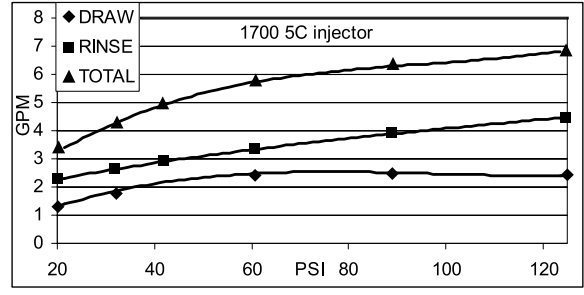
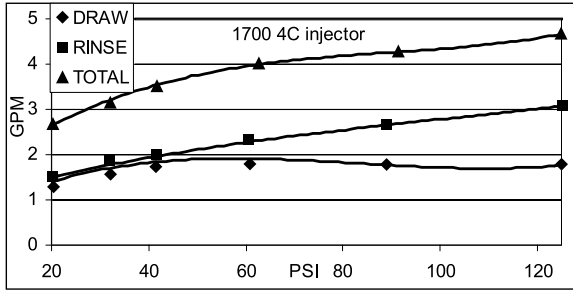
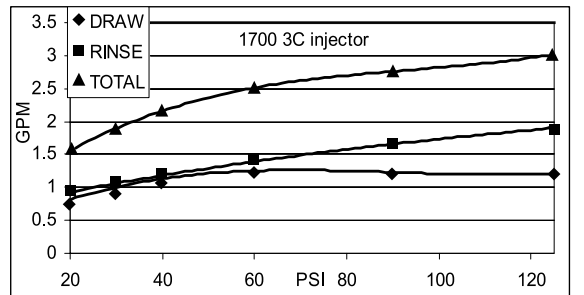
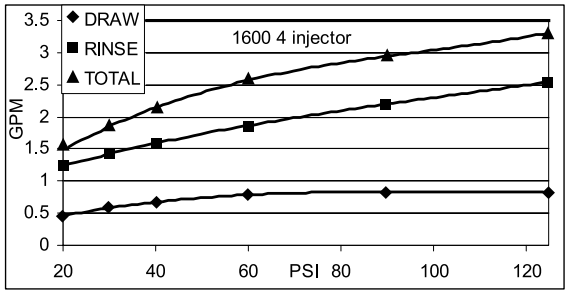
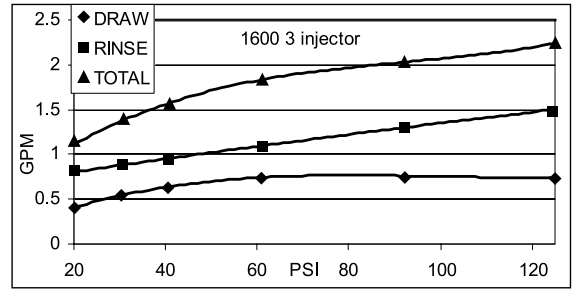
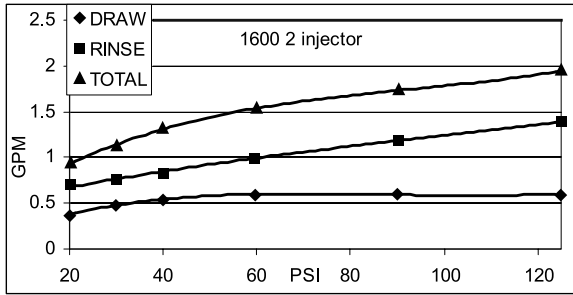
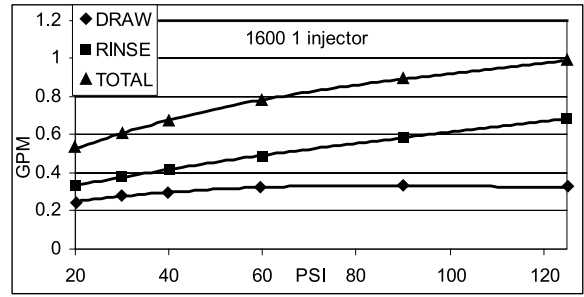
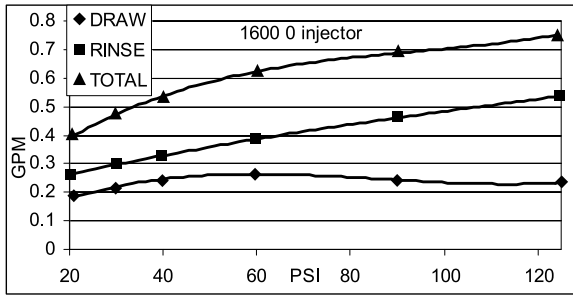

TR20391_REVA

DIMENSIONS

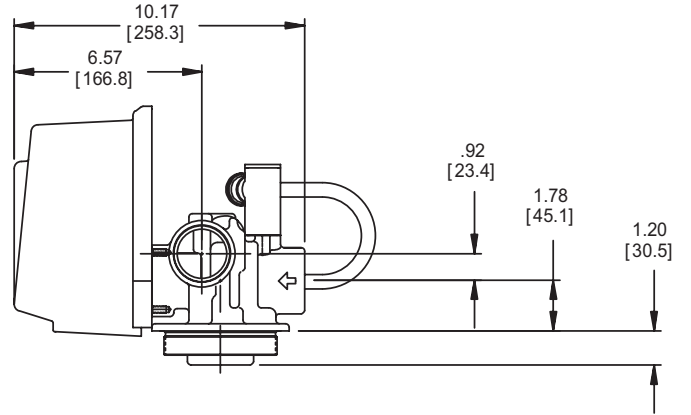
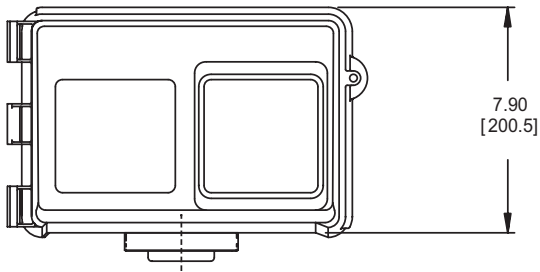
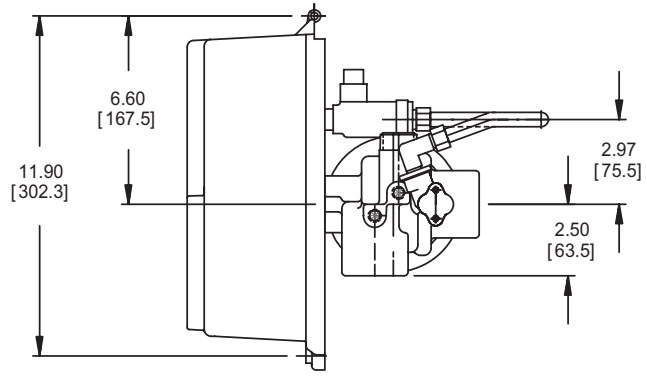

61500-2850 LNE Rev C

SYSTEM #4

Typical Single Tank Installation with Optional Meter

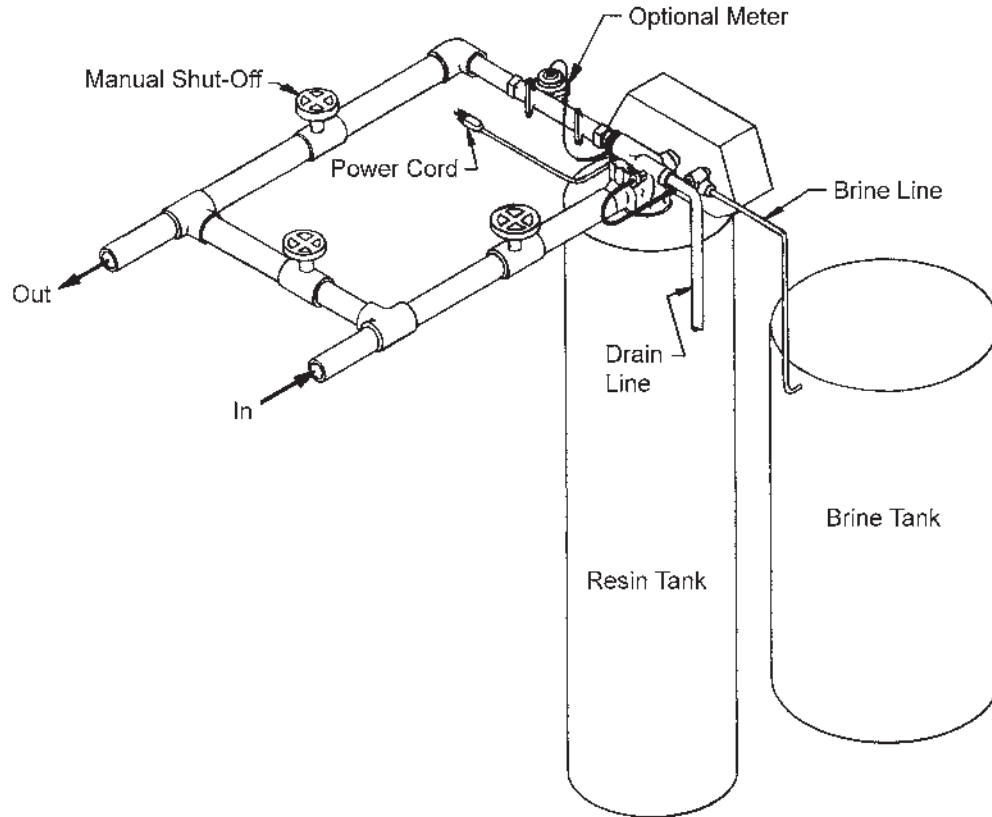

SYSTEM #5 INTERLOCK

Typical Twin Tank Installation with Optional Meter Interlock and No Hard Water Bypass

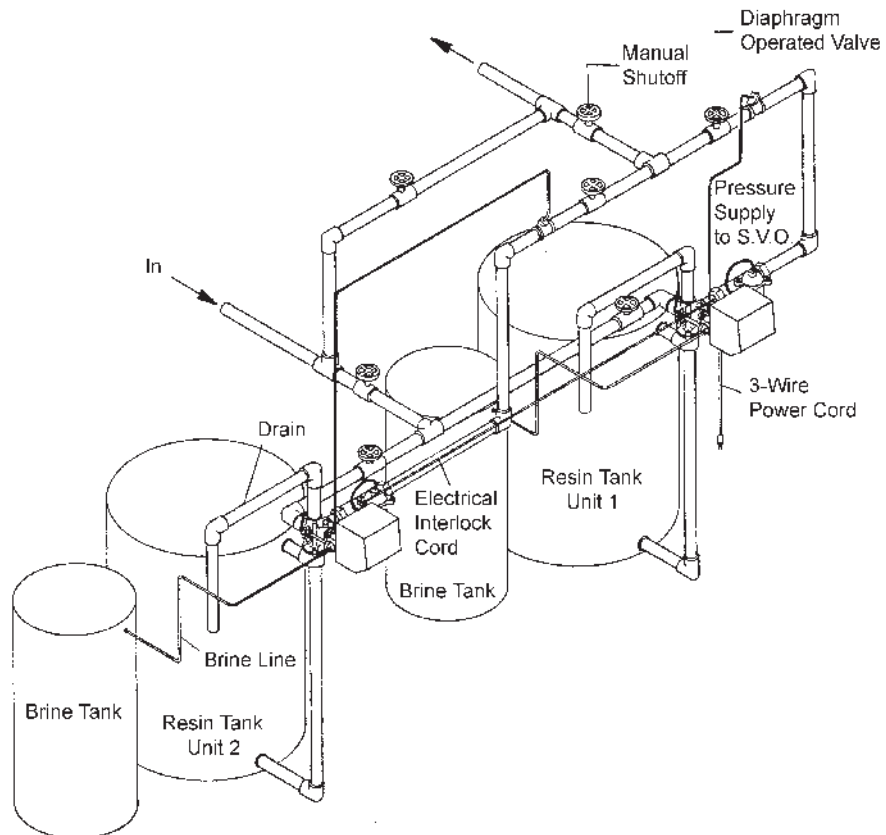

SYSTEM #6

Twin Series Regeneration Installation with a Remote Meter

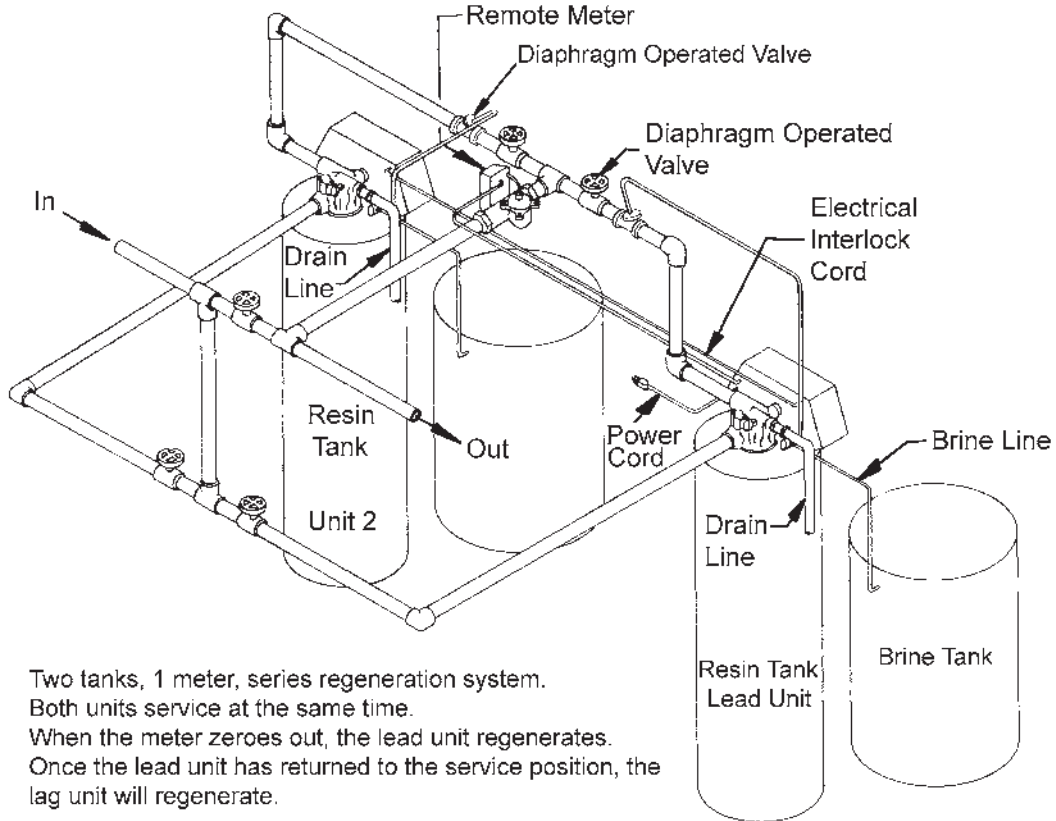

SYSTEM #7

Twin Alternator Installation with a Remote Meter

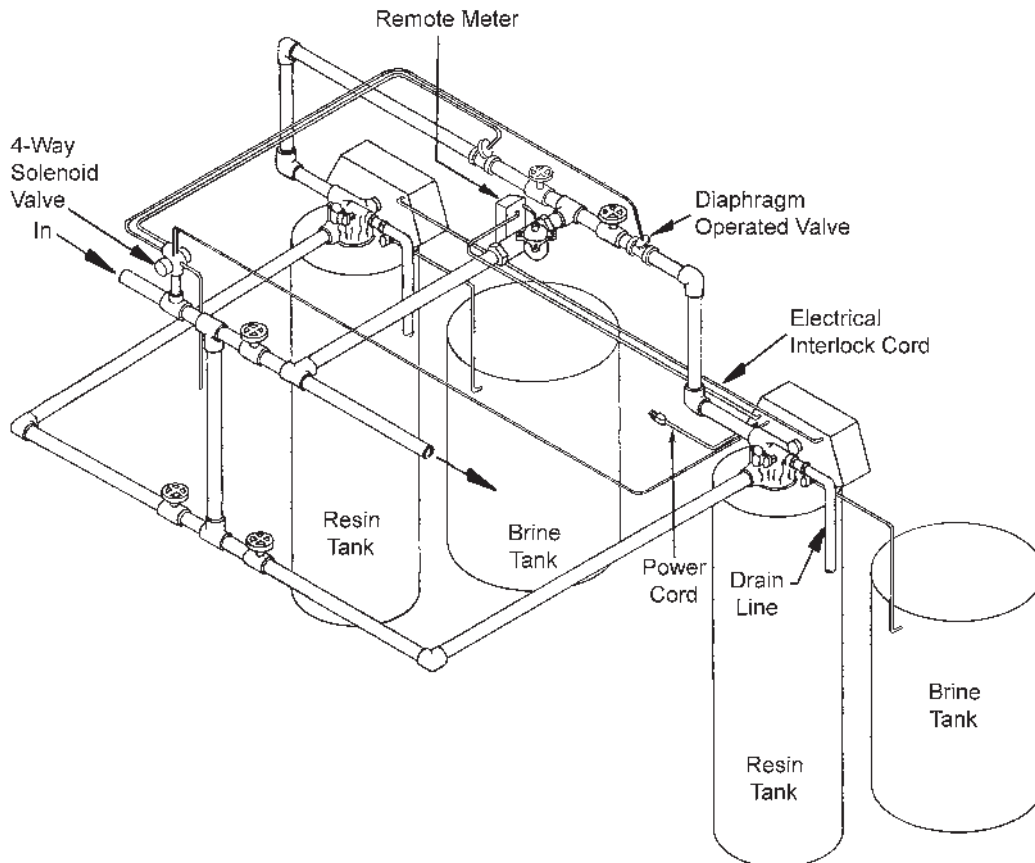

SYSTEM #4 WIRING

Single Valve Regeneration Immediate and Delayed Valve Wiring

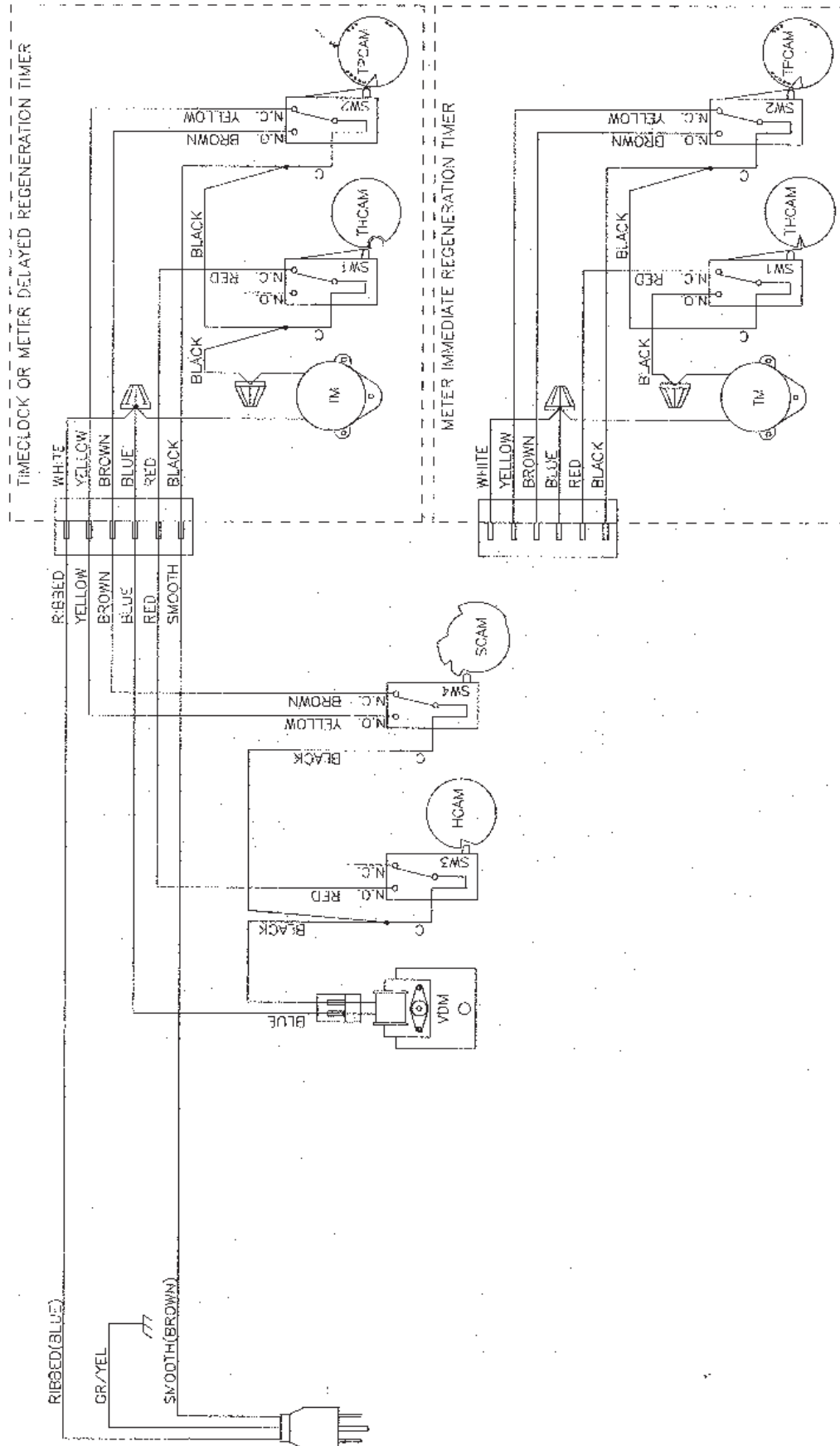

19201 Rev C

SYSTEM #4 WIRING *CONTINUED*

With Remote Starter Valve Wiring

REMOTE METER WIRING

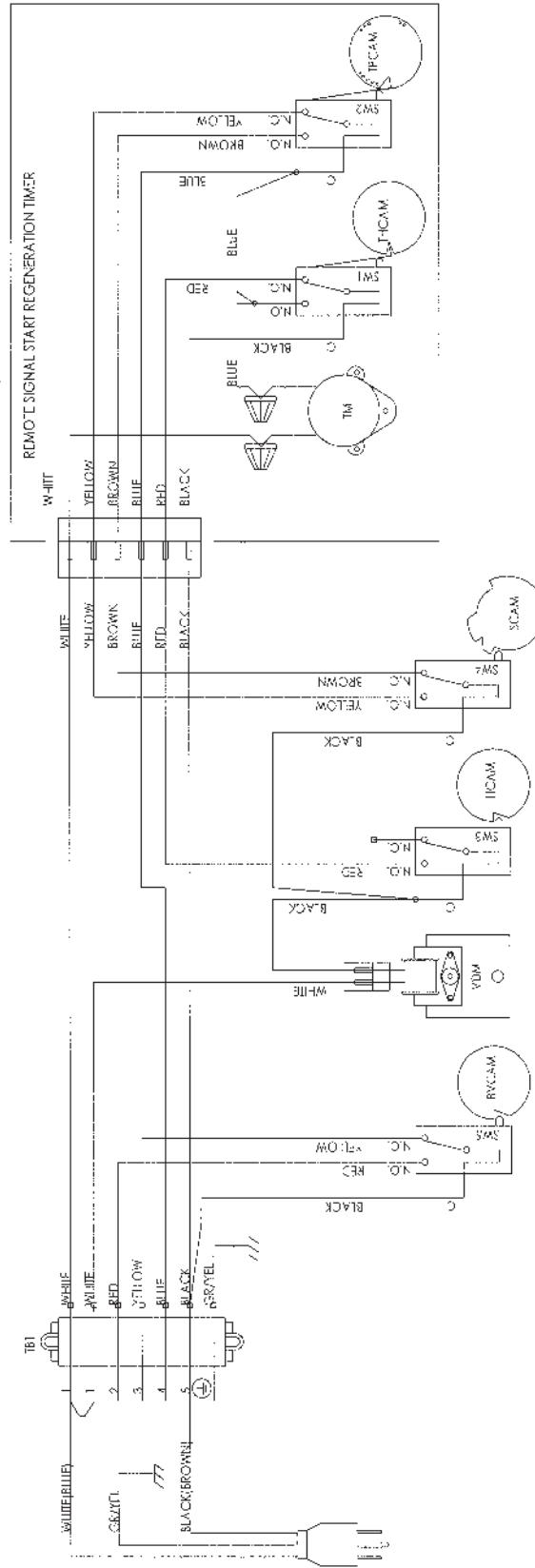
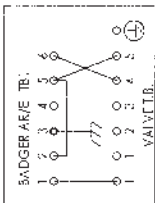
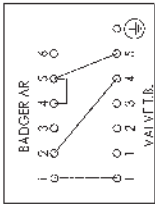
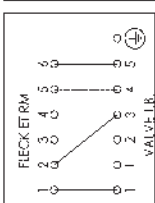
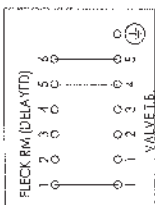
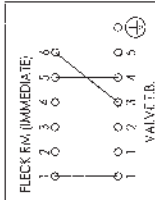

- TB1 - 7 POSITION TERMINAL BLOCK
- IM - IMMER MOTOR
- YDIM - VALVE DRIVE MOTOR
- SW1 - VALVE HOMING SWITCH
- SW2 - TIMER PROGRAM SWITCH
- SW3 - VALVE HOMING SWITCH
- SW4 - VALVE STEP SWITCH
- SW5 - BRINE CAM SWITCH
- I/CAM - TIMER HOMING CAM
- T/CAM - TIMER PROGRAM CAM
- H/CAM - VALVE HOMING CAM
- S/CAM - VALVE STEP CAM
- B/CAM - BRINE VALVE CAM

- NOTE:
1. SINGLE TANK REMOTE METER INITIATED DELAYED OR IMMEDIATE REGENERATION.
 2. WHITE VALVE WIRE THE POWER CORD IS REFLECTED WITH BLUE AND WHITE WIRES (WIRE BLUE TO TB1 #5, WHITE TO TB1 #1).
 3. VALVE SHOWN IN SERVICE POSITION.

SYSTEM #5 WIRING

Interlocked Regeneration Valve Wiring

/B4/ 1 PRODUCTION RELEASED
9726 B ADDED SHFT ?

LEAD

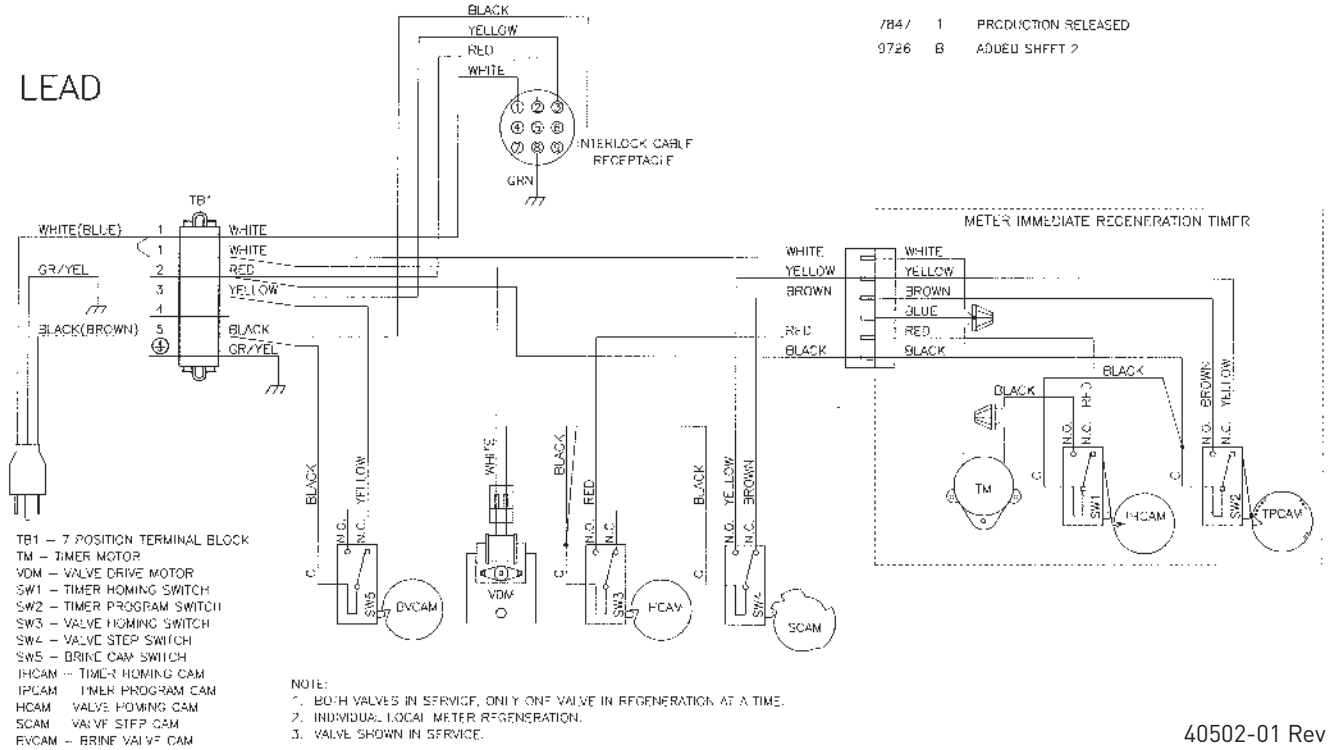

40502-01 Rev C

LAG

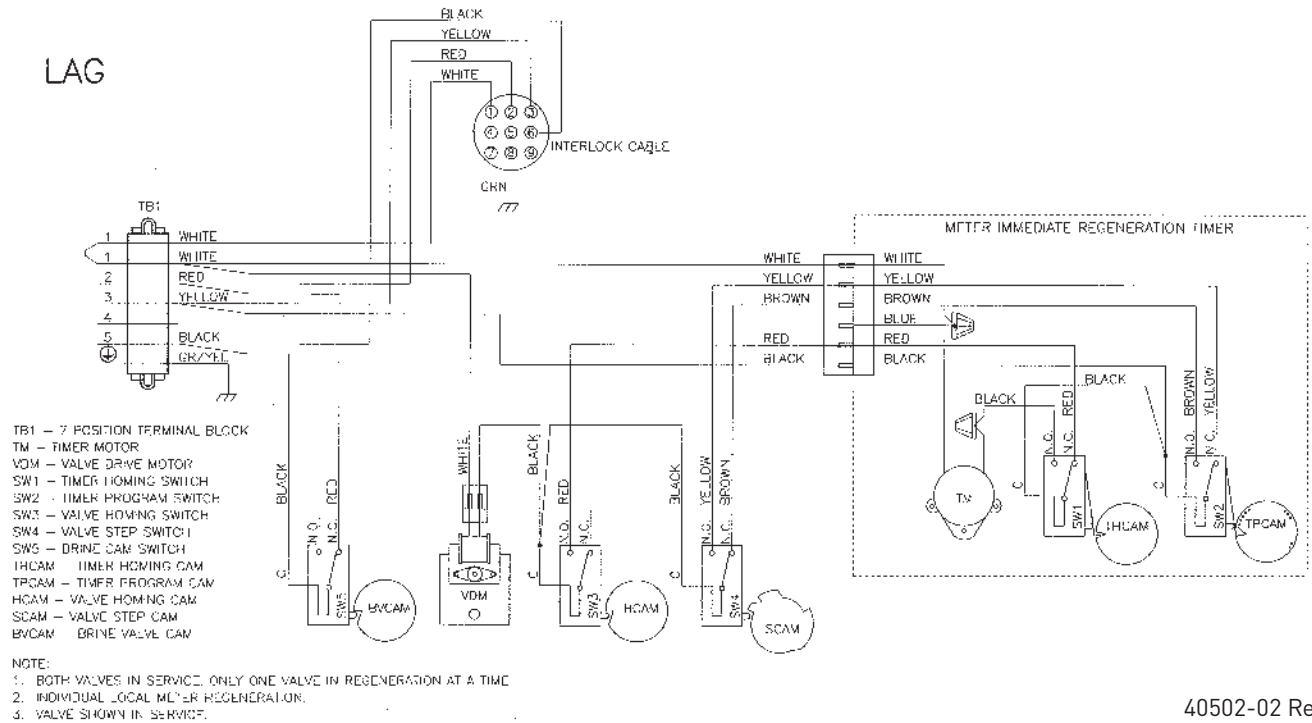

40502-02 Rev C

SYSTEM #6 WIRING

Series Regeneration Valve Wiring

REMOTE METER WIRING

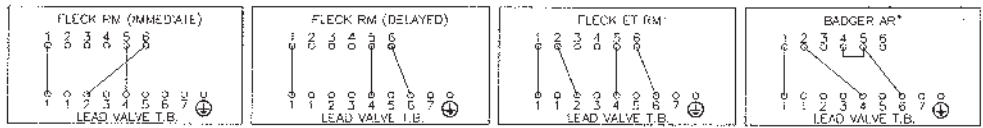

LEAD

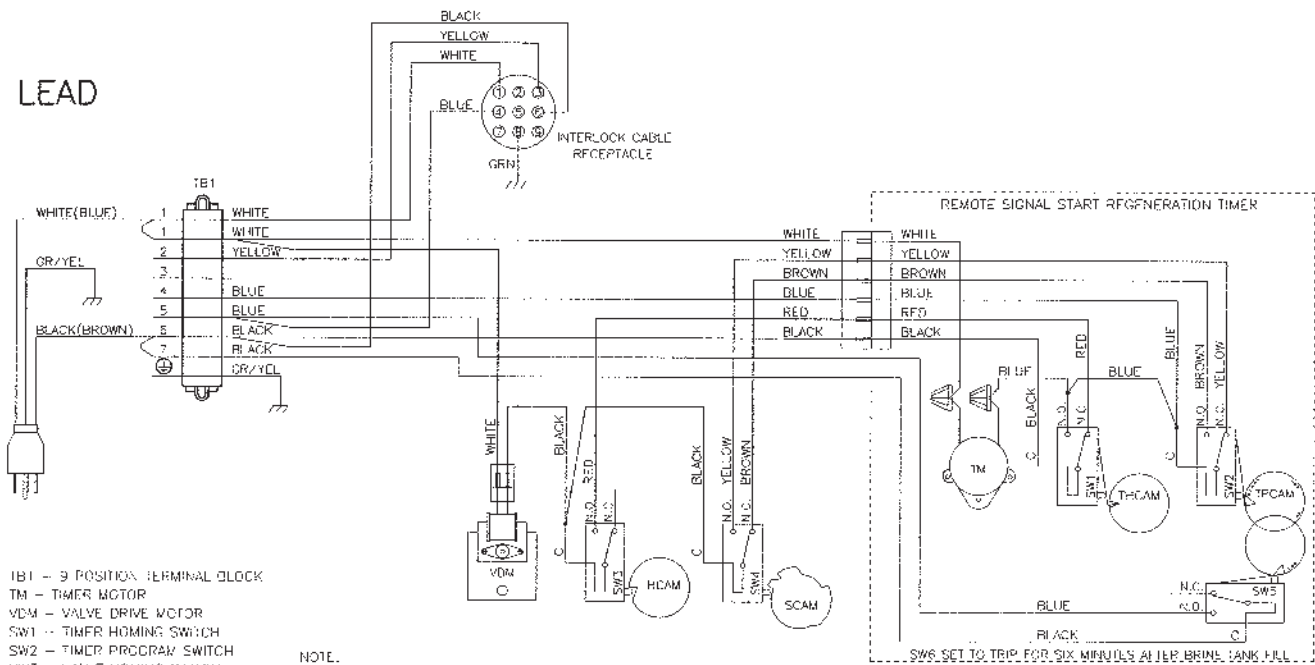

- TB1 - 9 POSITION TERMINAL BLOCK
- TM - TIMER MOTOR
- VDM - VALVE DRIVE MOTOR
- SW1 - TIMER HOMING SWITCH
- SW2 - TIMER PROGRAM SWITCH
- SW3 - VALVE HOMING SWITCH
- SW4 - VALVE STEP SWITCH
- SW5 - AUXILIARY TIMER SWITCH
- THCAM - TIMER HOMING CAM
- TPCAM - TIMER PROGRAM CAM
- HCAM - VALVE HOMING CAM
- SCAM - VALVE STEP CAM

- NOTE:
1. TWO TANK INTERLOCKED, SINGLE REMOTE METER, SERIES REGENERATION.
 2. BOTH TANKS NORMALLY IN SERVICE.
 3. ONLY ONE TANK IN REGENERATION, THE OTHER REMAINS IN SERVICE.
 4. LEAD VALVE REGENERATES FIRST, FOLLOWED IMMEDIATELY BY LAG VALVE.
 5. WITH 24V VALVES THE POWER CORD IS REPLACED WITH BLUE AND WHITE WIRES (WIRE BLUE TO TB1 #6, WHITE TO TB1 #1).
 6. VALVE SHOWN IN SERVICE POSITION.

13632-01 Rev L

LAG

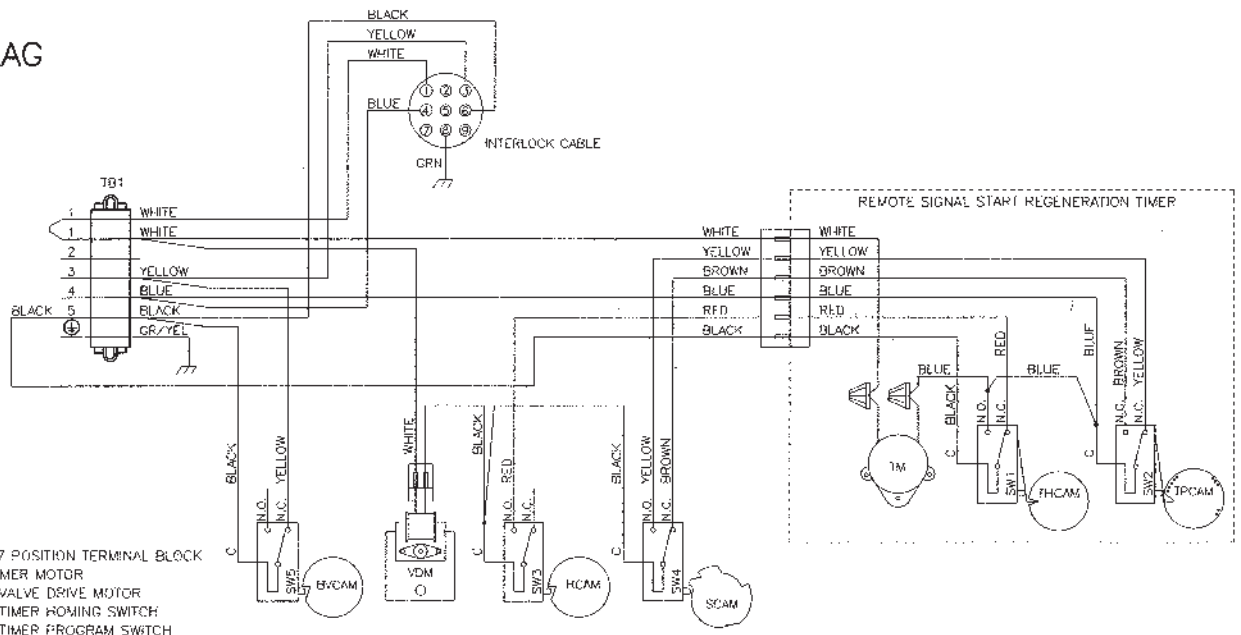

- TB1 - 7 POSITION TERMINAL BLOCK
- TM - TIMER MOTOR
- VDM - VALVE DRIVE MOTOR
- SW1 - TIMER HOMING SWITCH
- SW2 - TIMER PROGRAM SWITCH
- SW3 - VALVE HOMING SWITCH
- SW4 - VALVE STEP SWITCH
- SW5 - BRINE CAM SWITCH
- THCAM - TIMER HOMING CAM
- TPCAM - TIMER PROGRAM CAM
- HCAM - VALVE HOMING CAM
- SCAM - VALVE STEP CAM
- BVCM - BRINE VALVE CAM

- NOTE:
1. TWO TANK INTERLOCKED, SINGLE REMOTE METER, SERIES REGENERATION.
 2. BOTH TANKS NORMALLY IN SERVICE.
 3. ONLY ONE TANK IN REGENERATION, THE OTHER REMAINS IN SERVICE.
 4. LEAD VALVE REGENERATES FIRST, FOLLOWED IMMEDIATELY BY LAG VALVE.
 5. WITH 24V VALVES THE POWER CORD IS REPLACED WITH BLUE AND WHITE WIRES (WIRE BLUE TO TB1 #6, WHITE TO TB1 #1).
 6. VALVE SHOWN IN SERVICE POSITION.

13632-02 Rev L

SYSTEM #7 WIRING

Alternating Regeneration 24V / 120V / 3-Way Solenoid Output Valve Wiring

REMOTE METER WIRING

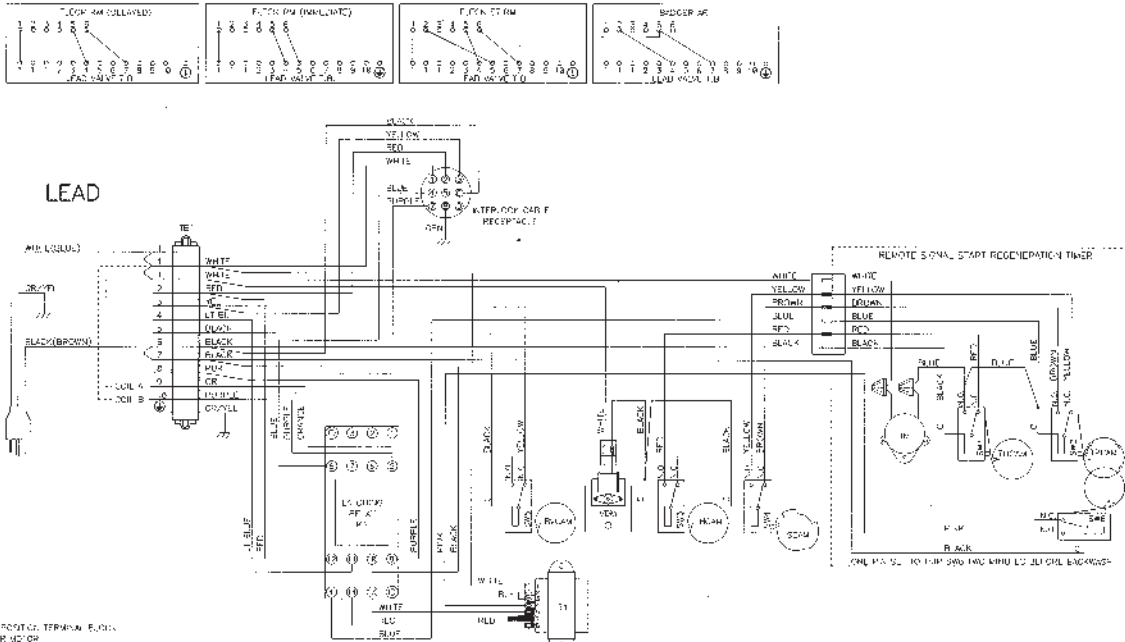

- TM1 - 1/2 POINTS TERMINAL BLOCK
 TM - TIMER MOTOR
 M - WATER DRIVE MOTOR
 T1 - 250V/120V COIL W/120V RT & 250V 1PH 50/60
 T2 - 250V/120V TRANSFORMER R/W 401-1
 SW1 - 120V/120V SWITCH
 SW2 - TIMER PROGRAM SWITCH
 SW3 - VALVE HOLDING SWITCH
 SW4 - VALVE DUMP SWITCH
 SW5 - TIMER RUN SWITCH
 SW6 - TIMER STOP/START SWITCH
 M1 - 120V/120V MOTOR
 M2 - 120V/120V MOTOR
 M3 - 120V/120V MOTOR
 M4 - 120V/120V MOTOR
 M5 - 120V/120V MOTOR
 M6 - 120V/120V MOTOR
 M7 - 120V/120V MOTOR
 M8 - 120V/120V MOTOR
 M9 - 120V/120V MOTOR
 M10 - 120V/120V MOTOR
 M11 - 120V/120V MOTOR
 M12 - 120V/120V MOTOR
 M13 - 120V/120V MOTOR
 M14 - 120V/120V MOTOR
 M15 - 120V/120V MOTOR
 M16 - 120V/120V MOTOR
 M17 - 120V/120V MOTOR
 M18 - 120V/120V MOTOR
 M19 - 120V/120V MOTOR
 M20 - 120V/120V MOTOR
 M21 - 120V/120V MOTOR
 M22 - 120V/120V MOTOR
 M23 - 120V/120V MOTOR
 M24 - 120V/120V MOTOR
 M25 - 120V/120V MOTOR
 M26 - 120V/120V MOTOR
 M27 - 120V/120V MOTOR
 M28 - 120V/120V MOTOR
 M29 - 120V/120V MOTOR
 M30 - 120V/120V MOTOR
 M31 - 120V/120V MOTOR
 M32 - 120V/120V MOTOR
 M33 - 120V/120V MOTOR
 M34 - 120V/120V MOTOR
 M35 - 120V/120V MOTOR
 M36 - 120V/120V MOTOR
 M37 - 120V/120V MOTOR
 M38 - 120V/120V MOTOR
 M39 - 120V/120V MOTOR
 M40 - 120V/120V MOTOR
 M41 - 120V/120V MOTOR
 M42 - 120V/120V MOTOR
 M43 - 120V/120V MOTOR
 M44 - 120V/120V MOTOR
 M45 - 120V/120V MOTOR
 M46 - 120V/120V MOTOR
 M47 - 120V/120V MOTOR
 M48 - 120V/120V MOTOR
 M49 - 120V/120V MOTOR
 M50 - 120V/120V MOTOR
 M51 - 120V/120V MOTOR
 M52 - 120V/120V MOTOR
 M53 - 120V/120V MOTOR
 M54 - 120V/120V MOTOR
 M55 - 120V/120V MOTOR
 M56 - 120V/120V MOTOR
 M57 - 120V/120V MOTOR
 M58 - 120V/120V MOTOR
 M59 - 120V/120V MOTOR
 M60 - 120V/120V MOTOR
 M61 - 120V/120V MOTOR
 M62 - 120V/120V MOTOR
 M63 - 120V/120V MOTOR
 M64 - 120V/120V MOTOR
 M65 - 120V/120V MOTOR
 M66 - 120V/120V MOTOR
 M67 - 120V/120V MOTOR
 M68 - 120V/120V MOTOR
 M69 - 120V/120V MOTOR
 M70 - 120V/120V MOTOR
 M71 - 120V/120V MOTOR
 M72 - 120V/120V MOTOR
 M73 - 120V/120V MOTOR
 M74 - 120V/120V MOTOR
 M75 - 120V/120V MOTOR
 M76 - 120V/120V MOTOR
 M77 - 120V/120V MOTOR
 M78 - 120V/120V MOTOR
 M79 - 120V/120V MOTOR
 M80 - 120V/120V MOTOR
 M81 - 120V/120V MOTOR
 M82 - 120V/120V MOTOR
 M83 - 120V/120V MOTOR
 M84 - 120V/120V MOTOR
 M85 - 120V/120V MOTOR
 M86 - 120V/120V MOTOR
 M87 - 120V/120V MOTOR
 M88 - 120V/120V MOTOR
 M89 - 120V/120V MOTOR
 M90 - 120V/120V MOTOR
 M91 - 120V/120V MOTOR
 M92 - 120V/120V MOTOR
 M93 - 120V/120V MOTOR
 M94 - 120V/120V MOTOR
 M95 - 120V/120V MOTOR
 M96 - 120V/120V MOTOR
 M97 - 120V/120V MOTOR
 M98 - 120V/120V MOTOR
 M99 - 120V/120V MOTOR
 M100 - 120V/120V MOTOR

- NOTE:
 1. THIS IS SINGLE REMOTE METER ALTERNATING REGENERATION ONLY. ONE OR TWO COILS ARE REQUIRED FOR REGENERATION ON STANDARD.
 2. CUSTOM WIRE FOR 3-WAY SOLENOID OUTPUT.
 COIL A CLOSURE THE DASHWAGON VALVES OF LAG UNIT.
 COIL B CLOSURE THE DASHWAGON VALVES OF LEAD UNIT.
 3. VALVE HOLDING SWITCH POSITION.

17727-01 Rev E

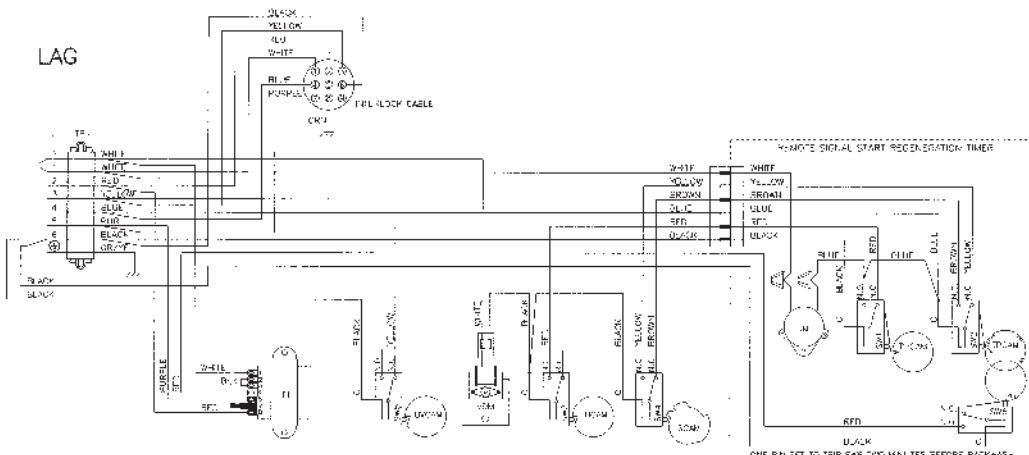

- TM1 - 1/2 POINTS TERMINAL BLOCK
 TM - TIMER MOTOR
 T1 - 250V/120V COIL W/120V RT & 250V 1PH 50/60
 T2 - 250V/120V TRANSFORMER R/W 401-1
 SW1 - 120V/120V SWITCH
 SW2 - TIMER PROGRAM SWITCH
 SW3 - VALVE HOLDING SWITCH
 SW4 - VALVE DUMP SWITCH
 SW5 - TIMER RUN SWITCH
 SW6 - TIMER STOP/START SWITCH
 M1 - 120V/120V MOTOR
 M2 - 120V/120V MOTOR
 M3 - 120V/120V MOTOR
 M4 - 120V/120V MOTOR
 M5 - 120V/120V MOTOR
 M6 - 120V/120V MOTOR
 M7 - 120V/120V MOTOR
 M8 - 120V/120V MOTOR
 M9 - 120V/120V MOTOR
 M10 - 120V/120V MOTOR
 M11 - 120V/120V MOTOR
 M12 - 120V/120V MOTOR
 M13 - 120V/120V MOTOR
 M14 - 120V/120V MOTOR
 M15 - 120V/120V MOTOR
 M16 - 120V/120V MOTOR
 M17 - 120V/120V MOTOR
 M18 - 120V/120V MOTOR
 M19 - 120V/120V MOTOR
 M20 - 120V/120V MOTOR
 M21 - 120V/120V MOTOR
 M22 - 120V/120V MOTOR
 M23 - 120V/120V MOTOR
 M24 - 120V/120V MOTOR
 M25 - 120V/120V MOTOR
 M26 - 120V/120V MOTOR
 M27 - 120V/120V MOTOR
 M28 - 120V/120V MOTOR
 M29 - 120V/120V MOTOR
 M30 - 120V/120V MOTOR
 M31 - 120V/120V MOTOR
 M32 - 120V/120V MOTOR
 M33 - 120V/120V MOTOR
 M34 - 120V/120V MOTOR
 M35 - 120V/120V MOTOR
 M36 - 120V/120V MOTOR
 M37 - 120V/120V MOTOR
 M38 - 120V/120V MOTOR
 M39 - 120V/120V MOTOR
 M40 - 120V/120V MOTOR
 M41 - 120V/120V MOTOR
 M42 - 120V/120V MOTOR
 M43 - 120V/120V MOTOR
 M44 - 120V/120V MOTOR
 M45 - 120V/120V MOTOR
 M46 - 120V/120V MOTOR
 M47 - 120V/120V MOTOR
 M48 - 120V/120V MOTOR
 M49 - 120V/120V MOTOR
 M50 - 120V/120V MOTOR
 M51 - 120V/120V MOTOR
 M52 - 120V/120V MOTOR
 M53 - 120V/120V MOTOR
 M54 - 120V/120V MOTOR
 M55 - 120V/120V MOTOR
 M56 - 120V/120V MOTOR
 M57 - 120V/120V MOTOR
 M58 - 120V/120V MOTOR
 M59 - 120V/120V MOTOR
 M60 - 120V/120V MOTOR
 M61 - 120V/120V MOTOR
 M62 - 120V/120V MOTOR
 M63 - 120V/120V MOTOR
 M64 - 120V/120V MOTOR
 M65 - 120V/120V MOTOR
 M66 - 120V/120V MOTOR
 M67 - 120V/120V MOTOR
 M68 - 120V/120V MOTOR
 M69 - 120V/120V MOTOR
 M70 - 120V/120V MOTOR
 M71 - 120V/120V MOTOR
 M72 - 120V/120V MOTOR
 M73 - 120V/120V MOTOR
 M74 - 120V/120V MOTOR
 M75 - 120V/120V MOTOR
 M76 - 120V/120V MOTOR
 M77 - 120V/120V MOTOR
 M78 - 120V/120V MOTOR
 M79 - 120V/120V MOTOR
 M80 - 120V/120V MOTOR
 M81 - 120V/120V MOTOR
 M82 - 120V/120V MOTOR
 M83 - 120V/120V MOTOR
 M84 - 120V/120V MOTOR
 M85 - 120V/120V MOTOR
 M86 - 120V/120V MOTOR
 M87 - 120V/120V MOTOR
 M88 - 120V/120V MOTOR
 M89 - 120V/120V MOTOR
 M90 - 120V/120V MOTOR
 M91 - 120V/120V MOTOR
 M92 - 120V/120V MOTOR
 M93 - 120V/120V MOTOR
 M94 - 120V/120V MOTOR
 M95 - 120V/120V MOTOR
 M96 - 120V/120V MOTOR
 M97 - 120V/120V MOTOR
 M98 - 120V/120V MOTOR
 M99 - 120V/120V MOTOR
 M100 - 120V/120V MOTOR

- NOTE:
 1. THIS IS SINGLE REMOTE METER ALTERNATING REGENERATION ONLY. ONE OR TWO COILS ARE REQUIRED FOR REGENERATION ON STANDARD.
 2. CUSTOM WIRE FOR 3-WAY SOLENOID OUTPUT.
 COIL A CLOSURE THE DASHWAGON VALVES OF LAG UNIT.
 COIL B CLOSURE THE DASHWAGON VALVES OF LEAD UNIT.
 3. VALVE HOLDING SWITCH POSITION.

17727-02 Rev E

SERVICE ASSEMBLIES

24 Hour Gear Assemblies

19205	Gear Assy, 24 Hour, Silver, 5600, 12 A.M.
60519-02	Gear Assy, 3200 24 Hour 2 Times/Day, w/Silver Label
60519-03	Gear Assy, 3200, 24 Hour 3 Times/Day, w/Silver Label
60519-04	Gear Assy, 3200, 24 Hour 4 Times/Day, w/Silver Label
60519-06	Gear Assy, 3200, 24 Hour (12:00) 6 Times/Day, w/Silver Label

Adapters

61415	Adapter Assy, Sidemount, 2850/2900/2930
61415NP	Adapter Assy, Sidemount, NP 2850/2900/2930
61415-20	Adapter Assy, Sidemount, BSP/MTC 2850/2900/2930
61415-20NP	Adapter Assy, Sidemount, BSP/NP 2850/2900/2930

Air Checks

60002-34	Air Check, #500, 34 inches Long
60003-34	Air Check, #500, HW, 34-inch Tube
60009-00	Air Check, #900, Commercial, Less Fittings
60009-01	Air Check, #900, Commercial, HW Less Fittings

Auxiliary Micro Switch

60320-02	Switch Kit, 3200/9000 Timer Auxiliary
60320-07	Switch Assy, 2850, Aux w/Self Tapping Screws
60320-12	Switch Assy, 1500 through 2850

Brine Line Flow Control (BLFC)

60020-25	BLFC, .25 GPM, 1600
60020-50	BLFC, .50 GPM, 1600
60020-100	BLFC, 1.0 GPM, 1600
60010-25	BLFC, 1650, .25 GPM, Plastic
60010-50	BLFC, 1650, .50 GPM, Plastic
60010-100	BLFC, 1650, 1.0 GPM, Plastic

Brine Valves

60011	Brine Valve, 1650, Less BLFC
60029	Brine Valve, 1600, Short Stem Brass, Std O-rings
60029HW	Brine Valve, 1600, Short Stem Hot Water
60034-xx	1700 Brine Valve Assy (Specify flow control 1.0 - 5.0)
60604-xx	Model 1710 Brine Valve Assy (Specify flow control 1.0 - 5.0)

Cam Assemblies

60160-15	Drive Cam Assy, STF, Blue
----------	-------	---------------------------

Covers

60219-xx	Environmental
60232-xx	Designer 2 Piece
60232-110	Cover, Designer, 1 Pc Black

Drain Line Flow Controls

60366-xx	1-inch FNPT x 3/4-inch FNPT (Specify flow control .6 - 7.0)
60701-xx	1-inch FNPT x 1-inch FNPT (Specify flow control 8.0 - 25.0)
60702-xx	1-inch FNPT x 1-inch MNPT (Specify flow control 8.0 - 25.0)
60708-xx	1-inch FNPT x 3/4-inch FNPT (Specify flow control 8.0 - 25.0)
60721-xx	1-inch FNPT x 1-inch FNPT (Specify flow control .6 - 7.0)

Drive Assemblies

60050-21	Drive Assy, 2750, STF, 120V Softener
----------	-------	--------------------------------------

Injector Assemblies (Complete)

60381-xx	1700 Injector Assy (Specify size of Injector)
60480-xx	1600 - 3/8-inch Brine (Specify size of injector)
60481-xx	1600 Brass - 3/8-inch Brine (Specify size of injector)

Meters

61933-10	1-1/2" NPT Stainless Steel Meter Assembly, Standard Range
61933-11	1-1/2" NPT Stainless Steel Meter Assembly, Extended Range
61933-20	1-1/2" BSP Stainless Steel Meter Assembly, Standard Range
61933-21	1-1/2" BSP Stainless Steel Meter Assembly, Extended Range
61560-01	Meter Assy, In-Line, w/1-inch NPT Plstc Connector
61560-07	Meter Assy, In-Line, w/1-inch NPT Brass Connector
61560-09	Meter Assy, In-Line, w/ 1-1/2 inches NPT Brass Connector

Piston Assemblies

60105	Piston Assy, 2850
60105-001	Piston Assy., 2850, 560CD
60105-01	Piston Assy., 2850, Hot Water
60114-00	Piston Assy, Filter, 2850 Conversion, NHWBP
60114-01	Piston Assy, 2850, NHWBP
60114-02	Piston Assy, 2850, 1600 Conversion, NHWBP
60114-03	Piston Assy, 2850, 1700 Conversion, NHWBP

Program Wheel Assemblies

60405-20	Program Wheel, with 3/4-inch Ext Label 1-1/2 inches Std Set @ 100
60405-30	Program Wheel, with 1-inch Std Label Set @ 50

SERVICE ASSEMBLIES *CONTINUED*

60405-40Program Wheel, w/1-inch Ext Label
60405-70Program Wheel, w/1-inch Ext Label

Safety Brine Valves

60014.....Safety Brine Valve Assy, 2310
60038.....Safety Brine Valve, 2350
60027-FFA.....Safety Brine Valve Body,
2300 Fitting Facing Arm
60027-FFS.....Safety Brine Valve Body Fitting Facing
Stud
60026-30SAN Float Assy, 2350, 30-inch HW
60028-30Float Assy, 2350, 30-inch, White
60028-30Float Assy, 2300, 30-inch, Blue/White
60068-30Float Assy, 2310, w/30-inch Rod

Sales and Service Aids

40726.....Literature, 2850 Spec Sheet
16510.....Literature, 2850 S/Manual
40717.....Literature, Catalog Assy, PWT
Residential/Commercial

Seal & Spacer Kits

60129.....Seal & Spacer Kit, 2850
60129-20Seal & Spacer Kit, 2850, Chemical
Resistant Seal

Service Equipment

16174.....Silicone, 2 oz. Tube
16586-8Silicone, Dow #7 8 Lb
16516.....Stuffer Assy, 2850/9500
17623.....Puller Tool Assy, 2850/9500
60460.....Meter Checker Kit, Std
60461.....Meter Checker Kit, Ext

Service Valve Operator Assemblies (SVO)

60150.....SVO Assy, 1600 O/S
60150-01SVO Assy, 1600 N/S

Skipper Wheel Assemblies

14860.....Skipper Wheel Assy, 7 Day
14381.....Skipper Wheel Assy, 12 Day

For Fleck® Product Warranties visit:
Fleck para las garantías de los productos visite: } [waterpurification.pentair.com](https://www.waterpurification.pentair.com)
Pour Fleck garanties produit visitez le site :



13845 BISHOPS DR., SUITE 200, BROOKFIELD, WI 53005
WATERPURIFICATION.PENTAIR.COM | CUSTOMER CARE: 800.279.9404 | tech-support@pentair.com

© 2018 Pentair Residential Filtration, LLC. All rights reserved.

§For a detailed list of where Pentair trademarks are registered, please visit [waterpurification.pentair.com/brands](https://www.waterpurification.pentair.com/brands). Pentair trademarks and logos are owned by Pentair plc or its affiliates. Third party registered and unregistered trademarks and logos are the property of their respective owners.

16510 REV N MY18