

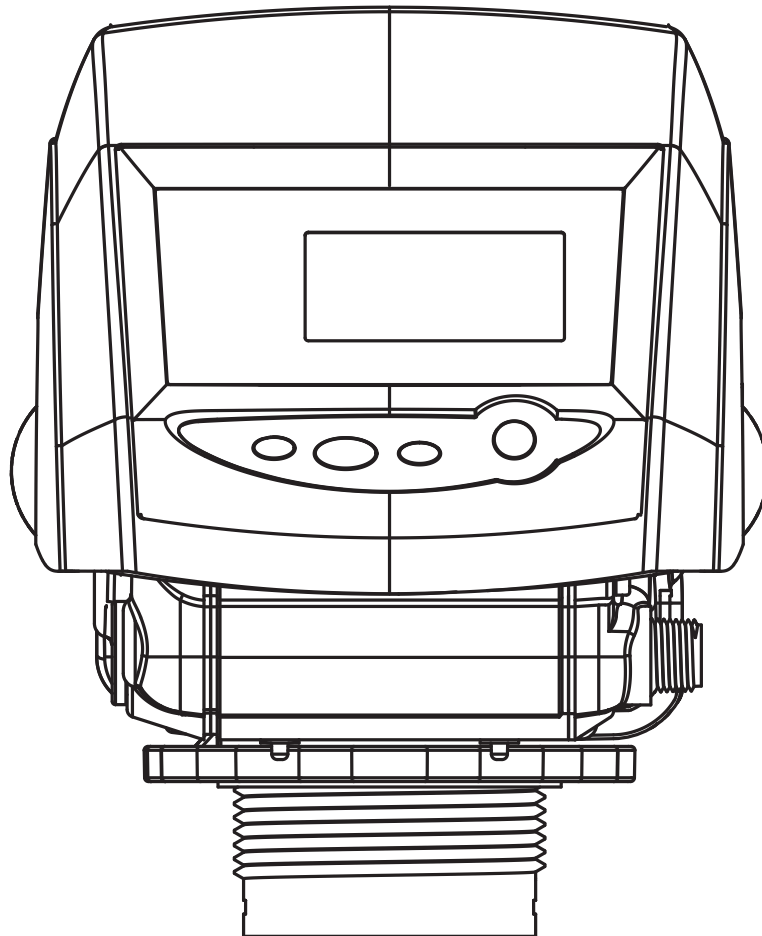

**AUTOTROL®** LOGIX™ 764 CONTROL  
PERFORMA CV SERIES VALVES (273, 278)  
SERVICE MANUAL



## TABLE OF CONTENTS

MANUAL OVERVIEW .....	2
SAFETY INFORMATION .....	2
LOCATION SELECTION .....	3
EQUIPMENT INSTALLATION.....	3
764 LOGIX CONTROL FEATURES .....	6
273/278 VALVE FEATURES.....	7
SYSTEM SPECIFICATIONS .....	8
700 SERIES CONTROLLER FEATURES.....	9
CONTROL DISPLAY ICONS .....	10
KEYPAD - BUTTONS .....	10
PLACING SYSTEM INTO OPERATION .....	11
PROGRAMMING .....	14
LEVEL I PROGRAMMING.....	16
LEVEL II PROGRAMMING .....	17
LEVEL III CYCLE PROGRAMMING.....	19
LEVEL IV VIEWING HISTORY.....	20
SERVICE AND MAINTENANCE .....	23
REFILL-FIRST OPTION .....	21
MANUAL REGENERATION OPTIONS.....	21
PROGRAM RESET .....	21
REGENERATION MODES FOR PARALLEL SYSTEMS .....	22
WIRING DIAGRAMS.....	29
ASSEMBLY DIAGRAMS.....	31
TROUBLESHOOTING.....	35
FLOW DIAGRAMS.....	38
FLOW DATA CHARTS.....	40

## MANUAL OVERVIEW

### How To Use This Manual

This installation manual is designed to guide the installer through the process of installing and starting water conditioning systems featuring the Logix 764 controller.

This manual is a reference and will not include every system installation situation. The person installing this equipment should have:

- Training in the 764 series control and the 273/278 valve.
- Knowledge of water conditioning and how to determine proper control settings.
- Adequate plumbing skills.

### Icons That Appear In This Manual

**⚠ WARNING:** Failure to follow this instruction can result in personal injury or damage to the equipment.

**⚠ CAUTION** Failure to follow this instruction can result in damage to the equipment.

**NOTE:** This will make the process easier if followed.

## SAFETY INFORMATION

### Electrical

There are no user-serviceable parts in the AC adapter, motor, or controller. In the event of a failure, these should be replaced:

- All electrical connections must be completed according to local codes.
- Use only the power AC adapter that is supplied.

- The power outlet must be grounded.
- To disconnect power, unplug the AC adapter from its power source.
- Install an appropriate grounding strap across the inlet and outlet piping of the water system to ensure proper grounding is maintained.

### Mechanical

- Do not use petroleum based lubricants such as petroleum jelly, oils, or hydrocarbon based lubricants. Use only 100% silicone lubricants.
- All plastic connections should be hand tightened. Plumber's tape may be used on connections that do not use an O-ring seal. **Do not use pliers or pipe wrenches.**
- All plumbing must be completed according to local codes.
- Soldering near the drain line should be done before connecting the drain line to the valve. Excessive heat will cause interior damage to the valve.
- Do not use lead-based solder for sweat solder connections.
- The drain line must be a minimum of 1/2" diameter. Use 3/4" pipe if the backwash flow rate is greater than 5 GPM (18.9 Lpm) or the pipe length is greater than 20' (6 m).
- Do not support the weight of the system on the control valve fittings, plumbing, or the bypass.

### General

- Keep the media tank in the upright position. Do not turn on side, upside down, or drop. Turning the tank upside down will cause media to enter the valve.
- Operating ambient temperature is between 34°F (1°C) and 120°F (49°C).
- Operating water temperature is between 34°F (1°F) and 100°F (38°C).
- Working water pressure range is 20 to 120 psi (1.38 to 8.27 bar). In Canada the acceptable working water pressure range is 20 to 100 psi (1.38 to 6.89 bar).
- Use only regenerant salts designed for water softening. Do not use ice melting, block, or rock salts.
- Follow state and local codes for water testing. Do not use water that is micro-biologically unsafe or of unknown quality.
- When filling media tank, do not open water valve completely. Fill tank slowly to prevent media from exiting the tank.
- When installing the water connection (bypass or manifold) connect to the plumbing system first. Allow heated parts to cool and cemented parts to set before installing any plastic parts. Do not get primer or solvent on O-rings, nuts, or the valve.

## CALIFORNIA PROPOSITION 65 WARNING

**⚠ WARNING:** This product contains chemicals known to the State of California to cause cancer or birth defects or other reproductive harm.

## LOCATION SELECTION

Location of a water treatment system is important. The following considerations must be taken into account when selecting the location for the water conditioning system:

- Level platform or floor.
- Constant electrical supply to operate the controller.
- Locate drain or tub for discharge as close as possible.
- Water line connections with shutoff or bypass valves.
- Must meet any local and state codes for site of installation.
- Do not install the unit near acid or acid fumes.
- Do not expose the unit to petroleum products.
- Valve is designed for minor plumbing misalignments. Do not support weight of system on the plumbing.
- Be sure all soldered pipes are fully cooled before attaching the plastic valve to the plumbing.
- If supplementary water treating equipment is required, make sure that adequate additional space is available. Locate the brine tank in an accessible place so that salt can be easily added.
- Do not install any system with less than 10' (3 m) of piping between the outlet of the conditioners and the inlet of the water heater. Water heaters can transfer heat down the cold water pipe into the control valve. Hot water can severely damage the conditioners.
- A 10' (3 m) total pipe run (including bends, elbows, etc.) is a reasonable distance to prevent hot water damage. A positive way to prevent hot water from flowing from a heat source to the conditioners is to install an expandable accumulator tank before the hot water heater. **Always conform to local codes.**

### Outdoor Locations

When the water conditioning system is installed outdoors, several items must be considered.

- Moisture — The valve and 700 controller are rated for NEMA 3 locations. Falling water should not affect performance. The system is not designed to withstand extreme humidity or water spray from below. Examples are: constant heavy mist, near corrosive environment, upwards spray from sprinkler.

**CAUTION** This unit is for dry location use only unless used with a Listed Class 2 power supply suitable for outdoor use.

- Direct Sunlight — The materials used will fade or discolor over time in direct sunlight. The integrity of the materials will not degrade to cause system failures. If it is necessary to locate the conditioner in direct sunlight, a protective outdoor cover (P/N 1267811) over the valve and controller is necessary.
- Temperature — Extreme hot or cold temperatures may cause damage to the valve or controller. Freezing temperatures will freeze the water in the valve. This will cause physical damage to the internal parts as well as the plumbing. High temperatures will affect the controller. The display may become unreadable but the controller should continue to function. When the temperature drops down into normal operating limits the display will return to normal. A protective cover, P/N 1267811, should assist with high temperature applications.

- Insects — The controller and valve have been designed to keep all but the smallest insects out of the critical areas. Any holes in the top plate can be covered with a metal foil duct work tape. The top cover should be installed securely in place.
- Wind — The Logix cover is designed to withstand a 30 mph (48 Kph) wind when properly installed on the valve.

## EQUIPMENT INSTALLATION

All plumbing must conform to local codes. The two tanks should be plumbed to an interconnecting manifold (see Figure 1 Typical Plumbing for Twin Tank Systems below). It is highly recommended that separate brine lines be used for each tank. It is critical for the resin, resin volume, inlet piping, etc. to be identical for both tanks.

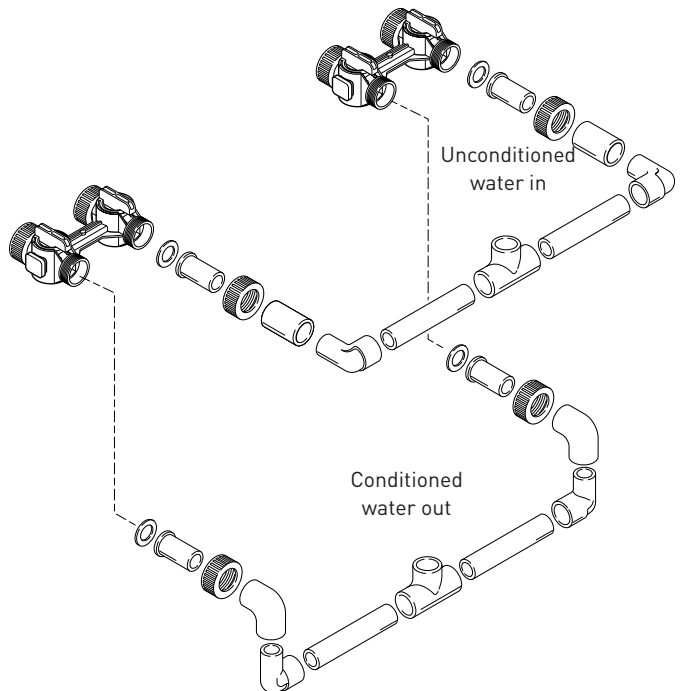

Figure 1 Typical Plumbing for Twin Tank Systems

## EQUIPMENT INSTALLATION *CONTINUED*

### Grounding the Plumbing

It is important that the plumbing system be electrically grounded. When a water softener is installed, a non-metallic bypass valve may interrupt the grounding. To maintain continuity, a grounding strap can be purchased at a hardware store (Figure 2). When installed, the strap will connect the inlet plumbing to the outlet plumbing to properly ground the system.

If you have other water treating equipment such as a chlorinator, sediment filter, neutralizer, iron filter, or taste and odor filter, they should be installed upstream of a water softener.

You may wish to consult a water professional if additional water treating equipment is to be installed.

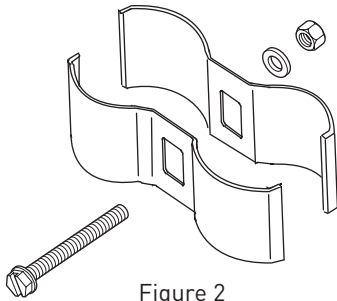

Figure 2

### Bypass Valve

A bypass valve system should be installed on all water conditioning systems. Bypass valves isolate the conditioner from the water system and allow unconditioned water to be used. Service or routine maintenance procedures may also require that the system is bypassed. Figures 3 and 4 show the two common bypass methods.

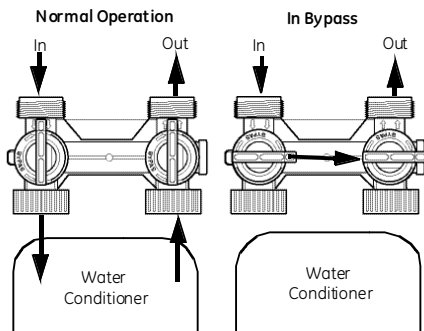

Figure 3 Series 1265 Bypass for Use with Perma Valve Bodies

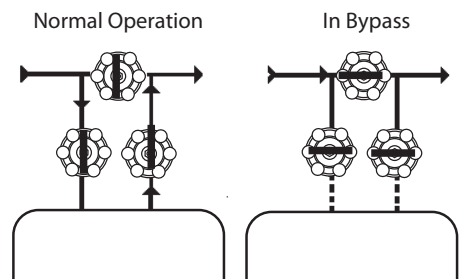

Figure 4 Typical Globe Valve Bypass System

### Brine Tank

Normally one brine tank is needed for each media tank. The use of block salt or rock salt is not recommended. If a brine shelf is used, two brine tanks are required. This is due to the increased time needed to produce a concentrated brine solution when using a salt shelf. If rapid multiple exhaustions and regenerations are anticipated, do not use a salt shelf even if two brine tanks are used.

### Drain Line Connection

**NOTE:** Standard commercial practices are expressed here. Local codes may require changes to the following suggestions. Check with local authorities before installing a water conditioning system.

- The unit should be above and not more than 20' (6.1 m) from the drain. Connect an appropriate adapter fitting and 3/4" (1.9 cm) plastic tubing to the drain line connection on the rear of the control valve.
- If the backwash flow rate exceeds 5 gpm (22.7 Lpm) or if the unit is located 20-40' (6.1-12.2 m) from drain, use 1" (2.5 cm) tubing. Use appropriate fittings to connect the tubing to the drain connection on valve.
- If the unit is located where the drain line must be elevated, the drain line may be elevated up to 5' (1.5 m), provided the run does **not** exceed 15' (4.6 m) and water pressure at the system is not less than 40 psi (2.76 bar). Elevation can be increased by 2' (61 cm) for each additional 10 psi (.69 bar) of water pressure at the drain connector.
- When the drain line is elevated, but empties into a drain below the level of the control valve, form a 7" (18 cm) loop at the far end of the line so that the bottom of the loop is level with the drain line connection. This will provide an adequate siphon trap. When the drain empties into an overhead sewer line, a sink-type trap must be used.

Secure the end of the drain line to prevent it from moving (see Figure 5 Drain Line Connection):

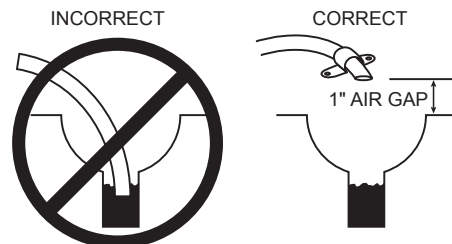

Construct air gap as shown or purchase air gap device as used with clothes washers.

Figure 5 Drain Line Connection

**NOTE:** Waste connections or the drain outlet should be designed and constructed to provide for connection to the sanitary waste system through an air gap of two pipe diameters or 1" (22 mm), whichever is larger.

**⚠ WARNING:** Never insert a drain line directly into a drain, sewer line, or trap (Figure 5 Drain Line Connection). Always allow an air gap between the drain line and the wastewater to prevent the possibility of sewage being back-siphoned into the softener.

## EQUIPMENT INSTALLATION *CONTINUED*

### Brine Line Connection

**NOTE:** It is recommended that separate brine lines be used for each tank.

The brine line from the brine tube connects to the valve. Be certain the connections are hand tightened. Make sure that the salt line is secure and free from any air leaks. Even a small leak may cause the brine line to drain out, and the system will not draw brine from the tank. This may also introduce air into the valve causing problems with valve operation. Ensure that plumbers tape is applied to the 3/8" NPT brine line connection (Figure 6 Regenerant Connection).

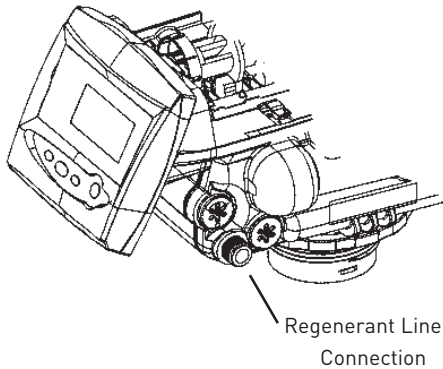

Figure 6 Regenerant Connection

To install the brine line:

1. Inside the brine tank, remove the cap from the large cylinder to gain access to the connection.
2. Be sure the brass insert is in the end of the brine tubing. Insert the tubing through the opening in the tank.
3. Push the tubing into the plastic nut. Slowly unscrew the nut until the tubing moves into the connection. The tubing will hit bottom.

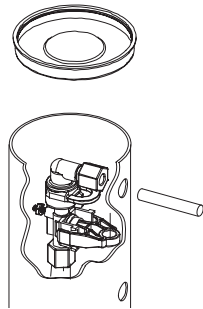

Figure 7

**NOTE:** Once the tubing has been pushed into the nut it cannot be pulled out. The nut will need to be removed. See Figure 8 for correct assembly.

4. Hand tighten the nut until the connection is tight.

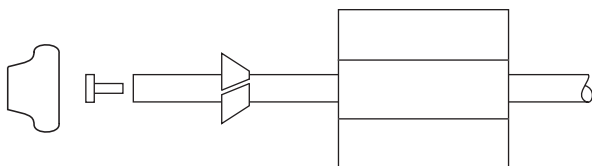

Figure 8

### Electrical Connection

**⚠ WARNING:** This valve and control are for dry location use only unless used with a Listed Class 2 power supply suitable for outdoor use.

The 764 Series control operates on a 12 volt alternating current power supply. This requires use of the supplied AC adapter. A variety of AC adapters are available from your supplier for different applications. They include:

AC Adapter	Input Voltage	Application	Part Number
Standard wall-mount	120 V 60 Hz	UL listed for indoor installations	1000811
Outdoor rated	120 V 60 Hz	UL listed for outdoor installations	1235448

#### 120 VAC Adapters

Make sure the power source matches the rating printed on the AC adapter.

**NOTE:** The power source should be constant. Be certain the AC adapter is not on a switched outlet. Power interruptions longer than eight hours may cause the controller to lose the time setting. When power is restored, the time setting must then be re-entered.

**NOTE:** Do not connect power by plugging in the transformer at this time. Doing so may cause difficulty in properly placing the unit into operation.

**CAUTION** Plumbing cannot be used for electrical grounding when metal inlet and outlet piping is connected to a non-metal valve. Connect the inlet and outlet piping together using a grounding strap or clamp to establish continuity.

# 764 LOGIX CONTROL FEATURES

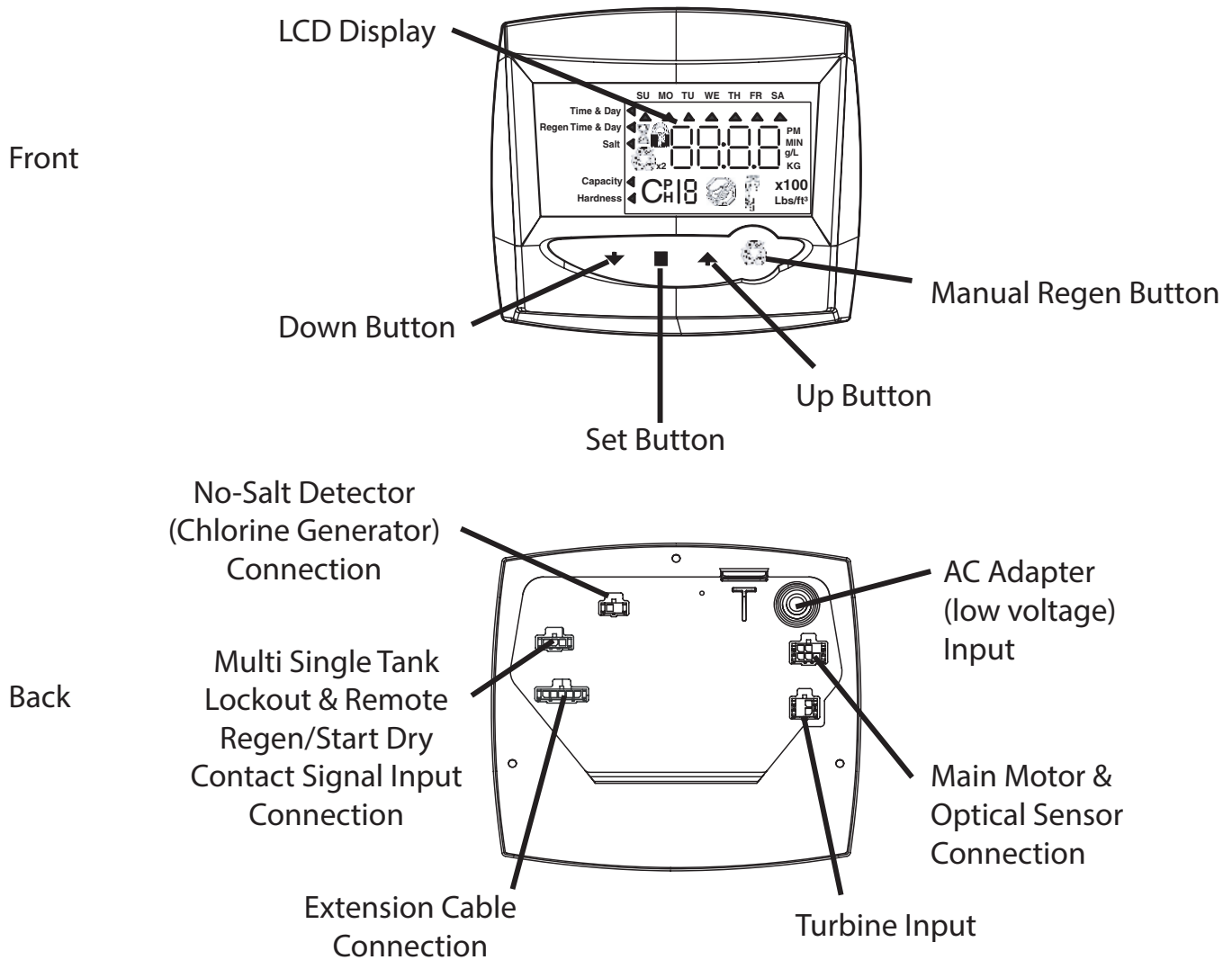

Figure 9 764 Controller Identification

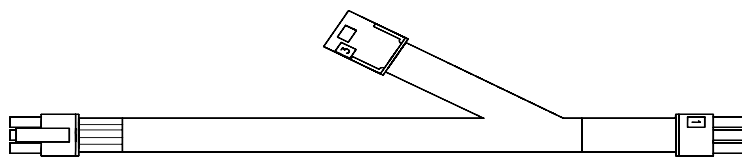

Figure 10 Remote Start/Multi-Tank Lockout Cable

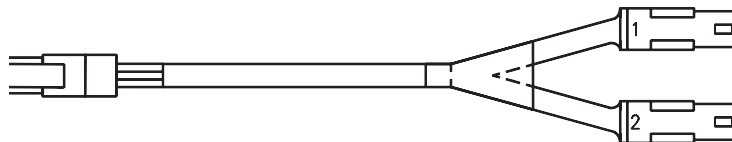

Figure 11 Twin Sensor Cable

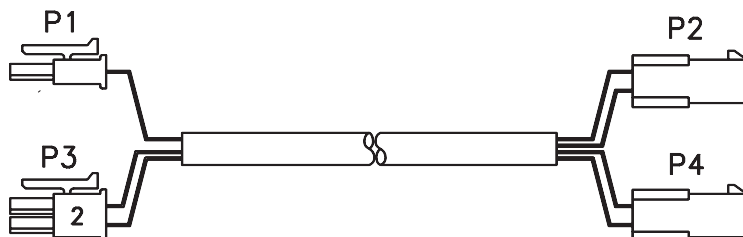

Figure 12 Twin Cable Extension

# 273/278 VALVE FEATURES

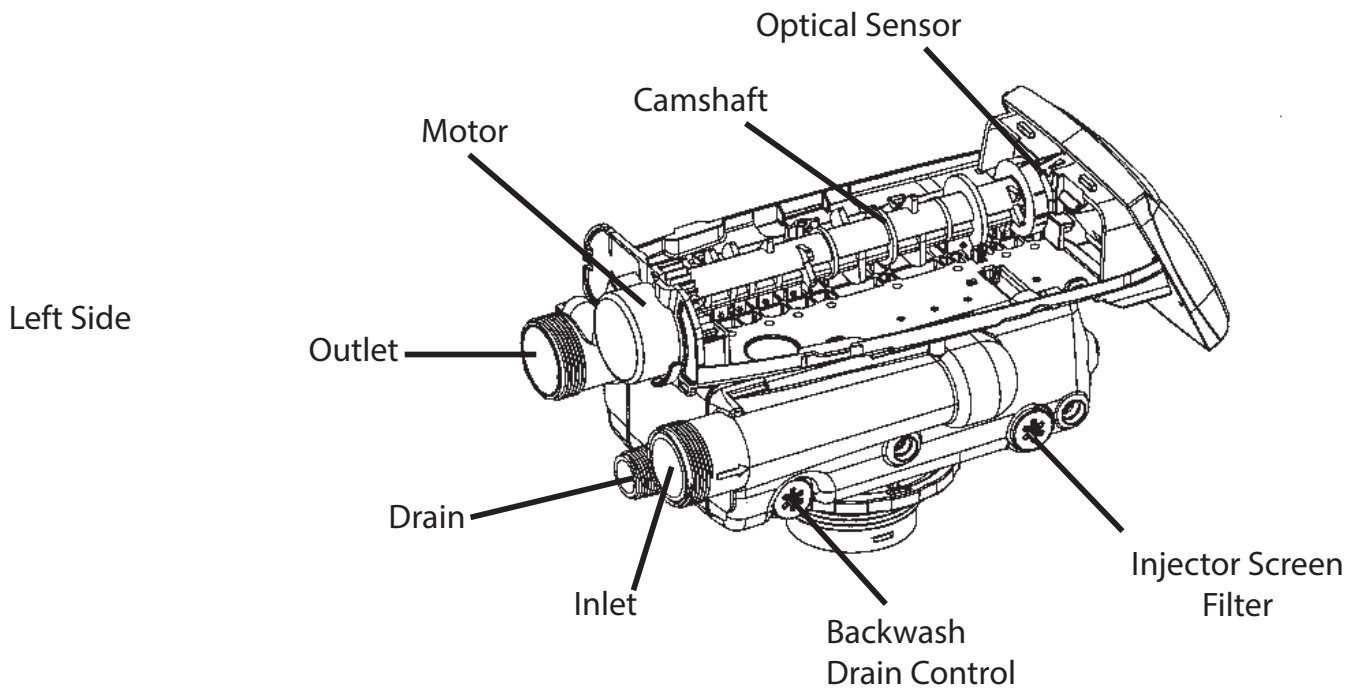
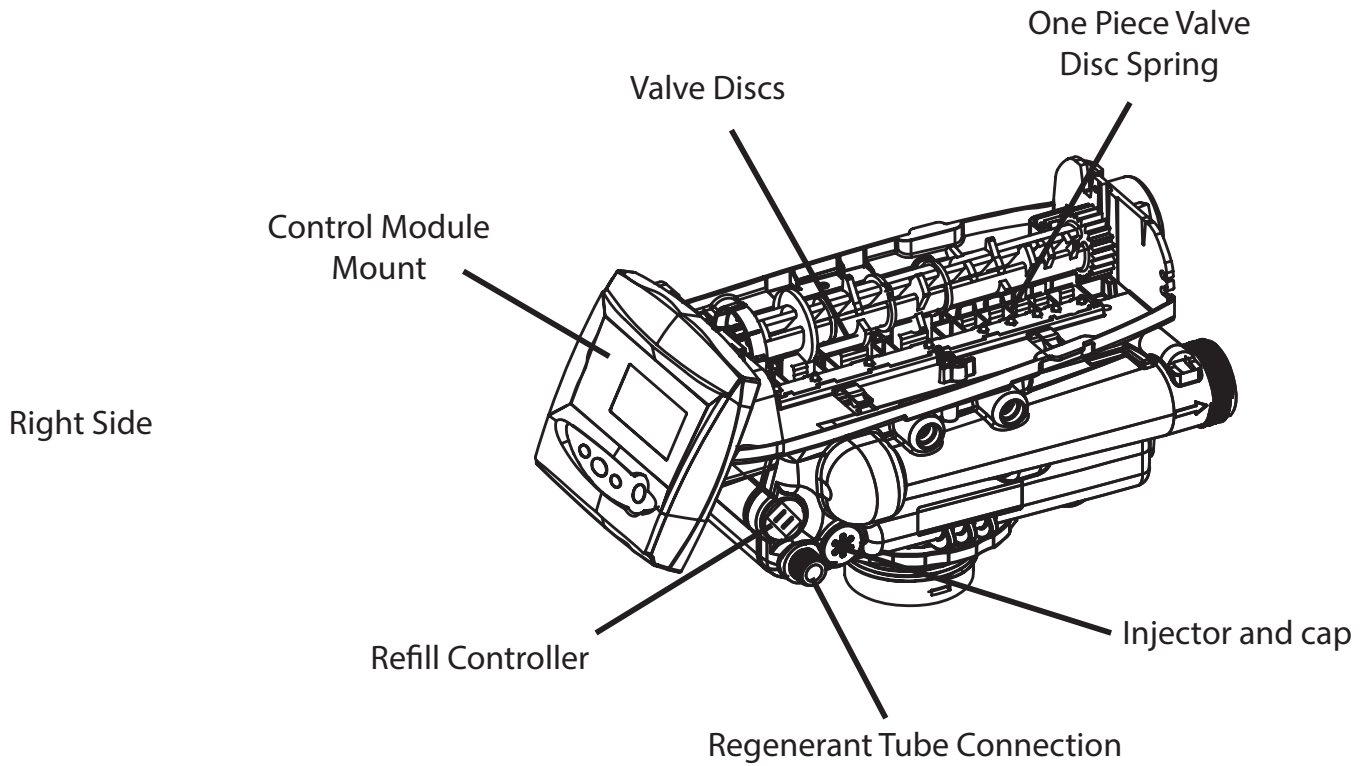

Figure 13 273/278 Valve Layout

# SYSTEM SPECIFICATIONS

## System Regeneration Cycles

### 1. Service (Downflow) — Cycle C0:

Untreated water is directed down through the resin bed and up through the riser tube. The hardness ions attach themselves to the resin and are removed from the water. The water is conditioned as it passes through the resin bed.

### 2. Backwash (Upflow) — Cycle C1:

The flow of water is reversed by the control valve and directed down the riser tube and up through the resin bed. During the backwash cycle, the bed is expanded and debris is flushed to the drain.

### 3. Brine/Slow Rinse (Downflow) — Cycles C2, C3:

The control directs water through the brine injector and brine is drawn from the regenerant tank. The brine is then directed down through the resin bed and up through the riser tube to the drain. The hardness ions are displaced by sodium ions and are sent to the drain. The resin is regenerated during the brine cycle. Brine draw is completed when the air check closes.

### 4. Repressurize Cycle — (Hard Water Bypass Flapper Open), Cycle C4:

This cycle closes the flappers for a short time to allow the air and water to hydraulically balance in the valve before continuing the regeneration.

### 5. Fast Rinse (Downflow) — Cycles C5:

The control directs water down through the resin bed and up through the riser tube to the drain. Any remaining brine residual is rinsed from the resin bed.

### 6. Brine Refill — Cycle C8:

Brine refill occurs during a portion of the fast rinse cycle. Water is directed to the regenerant tank at a controlled rate, to create brine for the next regeneration.

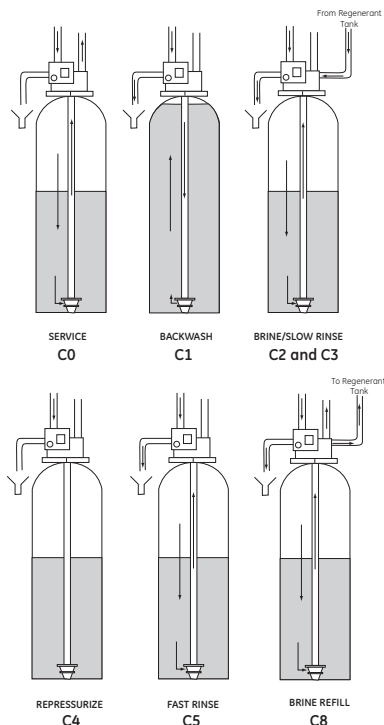

Figure 14

## Controller Location

The 700 Series controllers are designed to be mounted on the valve or attached to a flat surface. Installations that do not provide easy access to the valve can have the controller mounted for remote operation.

A remote mount connection, P/N 1256257, is available for the 700 Series controller.

## Valve Camshaft

The front end of the camshaft has an indicator cup. The cup has slots in the outer periphery and numbers on the inside face (Figure 15).

The numbers can be seen with the cover off, from the front over the top of the controller. The number at the top indicates which regeneration cycle is currently in progress.

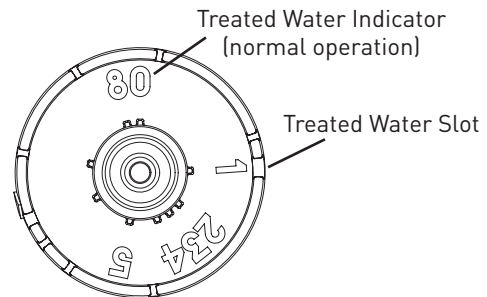

Figure 15 Camshaft Front End for 273 and 278 valve bodies  
The corresponding slot for the number is positioned at the optical sensor which is approximately 90 degrees out of phase.

## Regeneration Cycle Indicators

- C0 = Treated Water - normal operation mode
- C1 = Backwash Cycle
- C2 = Regenerant Draw Cycle (not used in filter mode)
- C3 = Slow Rinse Cycle (not used in filter mode)
- C4 = System Pause
- C5 = Fast Rinse Cycle
- C8 = Regenerant Refill (not used in filter mode)

## Valve Disc Operation

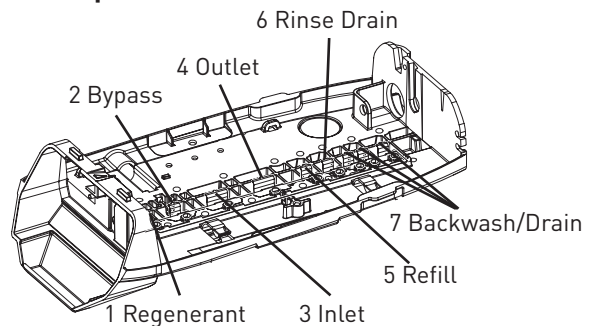

Figure 16 - Performa Valve (273, 278)

## **700 SERIES CONTROLLER FEATURES**

### **Power Loss Memory Retention**

The 700 series of controllers feature battery-free time of day and day of week retention during loss of power. The supplied super capacitor is designed to keep time for 8 to 24 hours, depending on the installation. If the super capacitor is exhausted, the Logix control will display four dashes (---) immediately upon power up. The time of day and day of week must be reset.

The controller will not track water usage on volumetric demand controls in the event of a power failure.

All programmed parameters are stored in the 700 Series static memory and will not be lost in the event of a power failure. These settings are maintained separately from the time and day settings.

### **Motor**

The 700 series controller uses a standard 12 volt AC motor that works with either 50 Hz or 60 Hz. The same motor is used worldwide and does not need to be changed for different power conditions.

### **Power**

700 Series controllers are available in two power configurations:

1. The North American model requires 60 Hz input. The controller will display USA units when power is first applied.
2. The World model accepts either 60 or 50 Hz input and will automatically adjust measurement units when power is first applied.

Information entered or calculated by the controller is stored in two different ways.

A static memory will store:

- Media volume
- Regenerant setting
- Time of regeneration
- Days between regeneration
- Filter mode

A dynamic memory with eight hour retention will store:

- Current day of week
- Running clock

**NOTE: Water flow to the valve can be turned on or bypassed when the controller is powered up for the first time.**

## CONTROL DISPLAY ICONS

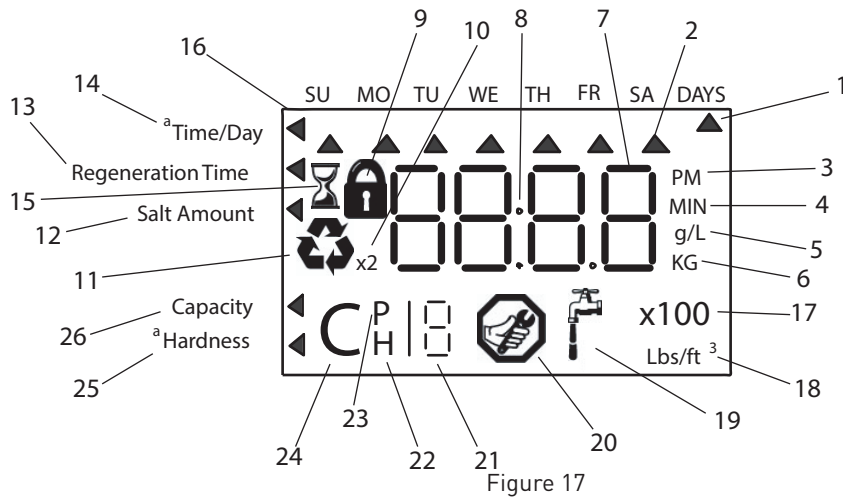

<sup>a</sup> If your Logix 764 controller was purchased as a filter control, the overlay will show: Time/Day, Backwash Time, Backwash Length and Capacity.

Figure 17

**NOTE: In normal operation and during programming, only a few of the icons will actually be displayed**

1. This cursor is displayed when the days between regeneration are being programmed (used with 5 to 99 day regeneration programming).
2. One of these cursors is displayed to indicate which day will be programmed into the controller.
3. "PM" indicates that the time displayed is between 12:00 noon and 12:00 midnight (there is no AM indicator). PM indicator is not used if clock mode is set to 24-hour.
4. When "MIN" is displayed, the value entered is in minute increments.
5. When "g/L" is displayed, the value for regenerant amount entered is in grams/liter.
6. When "Kg" is displayed, the value entered is in kilograms or kilograins.
7. Four digits used to display the time or program value. Also used for error codes.
8. Colon used as part of the time display.
9. Locked/unlocked indicator. In Level I programming, this is displayed when the current parameter is locked-out. It is also used in Level II programming to indicate if the displayed parameter is locked (icon flashes) when controller is in Level I.
10. When "x2" is displayed, a second regeneration has been called for.
11. The recycle sign is displayed (flashing) when a regeneration at the next time of regeneration has been called for. Also displayed (continuous) when in regeneration.
12. The display cursor is next to "SALT AMOUNT" when programming the amount of regenerant. If the controller is set to Filter then backwash time is programmed.
13. The display cursor is next to "REGENERATION TIME" when programming the time of regeneration and the days of regeneration.
14. The display cursor is next to "TIME/DAY" when programming the current time and day.
15. The hourglass is displayed when the motor is running. The camshaft should be turning.
16. These cursors appear next to the item that is currently displayed.
17. X100 multiplier for large values.
18. When Lbs/ft<sup>3</sup> is displayed the value for regenerant amount entered is in pounds/cubic foot.
19. Faucet is displayed when the current flow rate is displayed. Control may show the faucet and "0", indicating no flow.
20. Maintenance interval display turns on if the months in service exceed the value programmed in P11.
21. Used with #22, #23, and #24. Displays valve in service, a sequence number or a value.
22. History Values (H). The number displayed by #21 identifies which history value is currently displayed.
23. Parameter (P). Displayed only in Level II programming. The number displayed by #21 identifies which parameter is currently displayed.
24. Cycle (C). The number displayed by #21 is the current cycle in the regeneration sequence.
25. Hardness setting. Only used with 278 conditioners.
26. Capacity display. Shows estimated system capacity.

## KEYPAD - BUTTONS

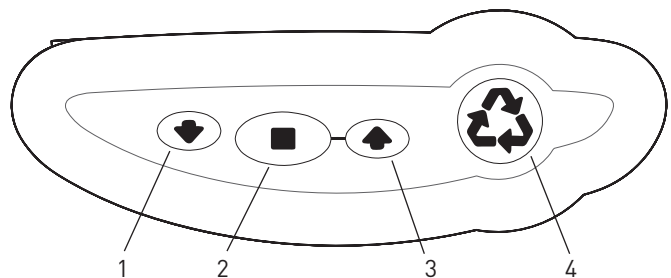

Figure 18

1. DOWN arrow. Generally used to scroll down or increment through a group of choices.
2. SET. Used to accept a setting that normally becomes stored in memory. Also used together with the arrow buttons.
3. UP arrow. Generally used to scroll up or increment through a group of choices.
4. Regenerate. Used to command the controller to regenerate. Also used to change the lock mode.

**NOTE: If a button is not pushed for 30 seconds, the controller returns to normal operation mode. Pushing the regenerate button immediately returns the controller to normal operation.**

## PLACING SYSTEM INTO OPERATION

After you have performed the installation steps, the system will need to be placed into operation.



**NOTE: All Logix 764 controls are shipped in the service (treated water) position.**

The incoming supply water should be turned off.

**Table 1 Pre-Programmed Values**

Type	Valve	System	Connection in Inches
255A	255	8-cycle conditioner	3/4
273A	273	Filter	1
278A	278	5-cycle conditioner	1
293A	293	Filter	2
298A	298	5-cycle conditioner	2
255P	255	8-cycle conditioner	3/4
273P	273	Filter	1
278P	278	5-cycle conditioner	1
293P	293	Filter	2
298P	298	5-cycle conditioner	2
255L	255	8-cycle conditioner	3/4
263L	263	Filter	1
268L	268	8-cycle conditioner	1
273L	273	Filter	1
278L	278	5-cycle conditioner	1
293L	293	Filter	2
298L	298	5-cycle conditioner	2

### Power Up the Control

1. Plug the transformer into a non-switched outlet. The display will show the valve type that was loaded from memory.  
If this is the first time the control is powered up, the display will show "255A".
2. Use the  or  buttons to increment through the available selections (Table 1). For the next steps you may want to remove the cover to watch the camshaft movement.
3. Press  to enter the value type and the proper pre-programmed valves for your application:  
273A: For twin alternating filter systems  
278A: For twin alternating conditioner systems  
273P: For twin parallel filter systems  
278P: For twin parallel conditioner systems  
273L: For single or multiple tank filter systems with regeneration lockout or remote regeneration start  
278L: For single or multiple tank conditioner systems with regeneration lockout or remote regeneration start
4. The display will show --:--. Select media volume or "F" for filter setup. If a number or "F" is displayed, the resin volume or a filter valve has been programmed.  
Finish programming the Logix 764 control using the Level I programming guide.  
The cam will move to service if not already in service. For alternating systems, Tank 1 will move to standby and Tank 2 will move to service. For parallel systems, both tanks will move to service.

These cam movements may take up to five minutes.

# PLACING THE SYSTEM INTO OPERATION

## CONTINUED

### 764 Control with 278 Conditioner Valve

Screen	Buttons to Press	Description	Range
	then ↓ or ↑ press ■	1. Resin Volume Select correct resin volume	Cubic feet: 0.25 to 3.00
	press ■ then ↓ or ↑ press ■	2. Time of Day (12 hr.) Set to time of day Note: Setting includes PM indicator.	
	press ■ then ↓ or ↑ press ■	3. Day of Week Set to actual day of the week.	
	press ■ then ↓ or ↑ press ■	4. Time of Regeneration Set to desired time of regeneration.	
	press ■ then ↓ or ↑ press ■	5. Days Override Leave at 0 to disable or Set to desired days between regeneration.	Days: 0 to 99
	press ■ then ↓ or ↑ press ■	6. Salt Dosage Set to desired dosage lbs per cubic feet of resin	Lbs/ft <sup>3</sup> : 3 to 18
	press ↓ to override press ■ then ↓ or ↑ press ■	7. Capacity Capacity calculated by Logix control Use to OVERRIDE cacluated capacity	Kilograins: 1 to 900
	press ■ then ↓ or ↑ press ■	8. Hardness Set to actual water hardness in grains per gallon	Grains/gal: 3 to 200

### Control programming is complete

**NOTE:** If the control displays Err3 and goes to the home position, the Regen icon will begin flashing. This indicates that a delayed regeneration will occur at the next programmed time of regeneration. If a delayed regeneration is not desired, press the REGEN button to disable the delayed regeneration and the system will regenerate by water usage.

# PLACING THE SYSTEM INTO OPERATION

## CONTINUED

### 764 Control with 273 Filter Valve

Screen	Buttons to Press	Description	Range
<p>Time/Day Backwash Time Backwash Length Capacity</p>	<p>press </p>	<p>1. Program Type — Select "F"</p>	
<p>Time/Day Backwash Time Backwash Length Capacity</p>	<p>press  then  or  press </p>	<p>2. Time of Day (12 hr.) — Set to actual time of day Note: Setting includes PM indicator.</p>	
<p>Time/Day Backwash Time Backwash Length Capacity</p>	<p>press  then  or  press </p>	<p>3. Day of Week — Set to actual day of the week</p>	
<p>Time/Day Backwash Time Backwash Length Capacity</p>	<p>press  then  or  press </p>	<p>4. Time of Backwash — Set to desired time of backwash Note: Time of Backwash is ignored for Twin-alternating.</p>	
<p>Time/Day Backwash Time Backwash Length Capacity</p>	<p>press  then  or  press </p>	<p>5. Days Override — Leave at 0 to disable or — Set to desired days override</p>	<p>Max. Days Between Regen: 0 to 99</p>
<p>Time/Day Backwash Time Backwash Length Capacity</p>	<p>press  then  or  press </p>	<p>6. Backwash Length (minutes) — Set to desired backwash length</p>	<p>Minutes: 0 to 200</p>
<p>Time/Day Backwash Time Backwash Length Capacity</p>	<p>press  then  or  press </p>	<p>7. Capacity (gallons) — Set to desired capacity in multiples of 100 gallons</p>	<p>Gallons: 1 x 100 to 900</p>

Control programming is complete

**NOTE:** If the control displays Err3 and goes to the home position, the Regen icon will begin flashing. This indicates that a delayed regeneration will occur at the next programmed time of regeneration. If a delayed regeneration is not desired, press the REGEN button to disable the delayed regeneration and the system will regenerate by water usage.

## PROGRAMMING

**CAUTION** If the system is a twin alternating conditioner (278A), go to "Quick Cycling the Control for Twin Alternating Systems".

### Quick Cycling the Control

It is required that the control be quick cycled to specific regeneration cycles when placing the system into operation. This will ensure that all of the air in the tank and valve is purged. The process also provides a check for leaks and functioning of the brine system. Please perform the following steps for quick cycling the control before proceeding to start up the system.

1. With the control in the treated water position, press and hold the REGEN button on the controller for five seconds. This will initiate a manual regeneration. The control will display a solid hourglass indicating that the motor and camshaft are turning to the backwash cycle (C1). When the control reaches the backwash cycle, the total regeneration time remaining will be displayed. Pressing the SET button will display the specific cycle time remaining.
2. While the controller is in cycle C1 (Backwash), open the water supply valve very slowly to approximately the 1/4 open position. Water will begin to enter the media tank. Any air remaining will begin to be purged to drain as the media tank fills with water.

**⚠ WARNING:** If opened too rapidly or too far, media may be lost out of the tank into the valve or the plumbing. In the 1/4 open position, you should hear air slowly escaping from the valve drain line.

When all of the air has been purged from the media tank (water begins to flow steadily from the drain line), open the main supply valve all the way. This will purge the final air from the tank.

Allow water to run to drain until the water runs clear from the drain line. This purges any debris from the media bed.

3. Press and release the UP and SET buttons to move the control to the Regenerant Draw cycle (C2).
4. Add water to the regenerant tank.
  - A. With a bucket or hose add approximately four gallons (15 liters) of water to the regenerant tank.
  - B. If the tank has a salt platform in the bottom of the tank, add water until the water level is approximately 1" (25 mm) above the platform.

**NOTE:** It is recommended that you do not put regenerant into the tank until after the control valve has been put into operation. With no regenerant in the tank, it is much easier to view water flow and motion in the tank.

5. Check regenerant draw.
6. Repeat step 3 to advance to each cycle.

Before the final filling of the media tank with water, check that:

  - The nearest water faucet is completely closed.
  - The valve drain line is properly routed to a drain.
  - The regenerant tank is empty and the regenerant hose is connected to the valve.
  - The water supply valve is off.

**NOTE:** The control can be sent directly back to the treated water position from any regeneration cycle. Press the UP and SET buttons (for about five seconds) until the hourglass icon begins flashing. The control will now skip all remaining regeneration cycles.

- A. C2 will be displayed. With the control in this position, check to see that the water is being drawn out of the regenerant tank. The water level in the regenerant tank should recede very slowly.
  - B. Observe that water is being drawn from the regenerant tank for at least three minutes. If the water level does not recede, check all regenerant line connections for air leaks.
7. If the water level is receding from the regenerant tank you can quick cycle the control to the C8 Regenerant tank refill position.
    - A. The control will cycle to the regenerant tank refill cycle, and water will be directed down through the regenerant line to the regenerant tank. Let the water flow through the line until all air bubbles have been purged from the line. Note: Do not let the water flow down the line to the tank for more than one to two minutes, or the tank may overflow.

**NOTE:** As you advance through each cycle there will be a slight delay before you can advance to the next cycle. There will be a pause after the regenerant draw and slow rinse cycles. This cycle (C4) is a re-pressurization cycle and is designed to allow the water pressure to equalize on each side of the valve discs. Allow the control to re-pressurize (three minutes) before cycling the control to the regenerant tank refill position.

8. Finally, turn on a faucet plumbed after the water conditioner. Run the faucet until the water runs clear.
9. Add the appropriate amount of regenerant to regenerant tank.

### The System is Now Fully Operational

**NOTE:** After any control reset (valve type or system change, etc.), it is necessary to initiate a manual regeneration and quick cycle through it. This will ensure the control and cam are synchronized. If not synchronized, Err3 will display and the control will drive cams to the correct position for the valve and system type programmed.

### Quick Cycling the Control for Twin Alternating Systems



It is required that the control be quick cycled to specific regeneration cycles when placing the conditioner into operation. This will ensure that all of the air in the tank and valve is purged. The process also provides a check for leaks and functioning of the brine system.

After the initial power up and programming, Tank 1 will be in standby and Tank 2 will be in service.

**Before the final filling of the media tanks with water, check that:**

- The nearest water faucet is completely closed.
- The valve drain line is properly routed to a drain.
- The regenerant tank is empty and the regenerant hose is connected to the valve.
- The water supply valve is partially open.
- Valve bypasses are in service positions.

## PROGRAMMING *CONTINUED*

During this process the valves will need to be quickly advanced to the next cycle. To quick cycle, press  and  after the regeneration cycle has started.

Alternating tank systems have one Logix 764 control that is mounted on Tank 1. Tank 2 has a blank faceplate and the Tank 2 valve is controlled by the Logix 764 control on Tank 1.

### Placing the Alternating System into Operation

1. Press and hold the  button for five seconds. This will start the first regeneration.

**NOTE:** Once the valve has reached the cycle (visible on the display and camshaft has stopped turning), quick cycle to the next cycle. This is especially recommended for the C8 cycle. Overfilling the regenerant tank will affect the brine and future regen cycles.

**NOTE:** It is recommended that you do not put regenerant into the tank until after the control valve has been put into operation. With not regenerant in the tank, it is much easier to view water flow and motion in the tank.

Tank 1 moves through cycles:

C5 - Fast Rinse: as the water enters the tank, air will be forced out the drain line. Once water fills the tank, it will then discharge out the drain line. Quick cycling the control can now be used to advance through the remaining cycles.

C8 - Regenerant Refill: the aircheck is filled and flow to the regenerant tank is visible.

Quick cycle Tank 1 to service

then--

Tank 2 moves through cycles:

C1 - Backwash: as water enters the tank, air will be forced out the drain line. Once water fills the tank, it will then discharge out the drain line. Quick cycling the control can now be used to advance through the remaining cycles.

C2 - Regenerant Draw: the regenerant tank should have water in it. As the draw occurs the level will go down.

C3 - Slow Rinse

C4 - Standby

Both tanks have now been purged of air. The water supply valve can be fully opened.

2. Press and hold the  button for five seconds. This will start the second regeneration.

Quick cycle as Tank 2 moves through cycles:

C5 - Fast Rinse

C8 - Regenerant Refill: the aircheck is filled and flow to the regenerant tank is visible.

then--

Quick cycle as Tank 1 moves through cycles:

C1 - Backwash

C2 - Regenerant Draw: the regenerant tank should have water in it. As the draw occurs the level will go down.

C3 - Slow Rinse

C4 - Standby

At this point Tank 1 is fully operational.

3. Press and hold the  button for five seconds. This will start the third regeneration. After this step both tanks will be ready.

Quick cycle as Tank 1 moves through cycles:

C5 - Fast Rinse

C8 - Regenerant Refill

Quick cycle to service

then--

Quick cycle as Tank 2 moves through cycles:

C1 - Backwash

C2 - Regenerant Draw: the regenerant tank should have water in it. As the draw occurs the level will go down.

C3 - Slow Rinse

C4 - Standby

Both tanks are now ready.

4. Turn on a faucet plumbed after the water conditioner. Run the faucet until the water runs clear.
5. Add water to the regenerant tanks.
  - A. With a bucket or hose, add water until approximately four gallons (15 liters) of water in each regenerant tank.
  - B. If the tank has a salt platform in the bottom of the tank, add water until the water level is approximately 1" (25 mm) above the platform.

### The Alternating Water Conditioning System is Now Fully Operational

**NOTE:** After any control reset (valve type or system change, etc.), it is necessary to initiate a manual regeneration and quick cycle through it. This will ensure the control and cam are synchronized. If not synchronized, Err3 will display and the control will drive cams to the correct position for the valve and system type programmed.

## PROGRAMMING CONTINUED

### In Service Display

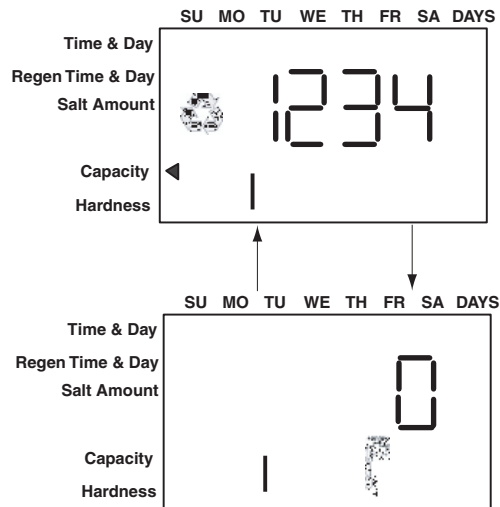

Figure 19

While the system is in service the display will provide different information depending on the system type selected.

#### Multi-Tank - "A" Alternating Control

- Number of the tank in service (small digit at bottom of display)
- Alternating Capacity Remaining
- Flow Rate with Faucet icon of tank in service

#### Multi-Tank - "P" Parallel Control

Three alternating items:

- Capacity remaining for Tank 1 with digit "1" displayed
- Capacity remaining for Tank 2 with digit "2" displayed
- System Flow Rate (Tank 1 + Tank 2 added) with Faucet icon

#### Multi-Tank - "L" Lock Out Control

- Capacity Remaining
- Flow Rate with Faucet icon
- "L" displayed indicating lockout signal is active
- Blinking "L" and Lock icon if lockout signal is active and control is ready to perform regeneration

**NOTE:** The faucet icon is displayed on all the Logix 764 controls when there is flow. The 764 will show the faucet icon when the flow rate is zero, the faucet will turn off when the capacity is displayed.

**NOTE:** In service flow rate display can be replaced with a clock display using Level II programming.

#### Programming Overview

The 764 control includes multiple program levels that allow the water treatment professional to customize the system for many water conditions. Additionally, historical data can be viewed allowing quick and easy troubleshooting. In most cases Level I programming is all that is required to set up the system for proper operation. A brief description of each program level is listed below.

Level I: Used to program control for normal applications.

Level II (P-Values): Allows the installer to customize programming for non-standard applications.

Level III (C-Values): Allows the installer to adjust the length of select cycles for non-standard applications.

Level IV History (H-Values): Allows access to historical information for troubleshooting the system.

**NOTE:** If a button is not pushed for thirty seconds, the control returns to normal operation mode.

#### Things You Might Need to Know

- When the controller is first plugged in, it may display a flashing hourglass and the message Err 3, this means that the controller is rotating to the home position. If the Err 2 is displayed, check that the incoming power frequency matches the controller. The North American controller will not run with 50 Hz input.
- The preset default time of regeneration is 2:00 AM.
- English or Metric? The World controller senses the electrical input and decides which is needed. The North American controller only runs on 60 Hz and defaults to English units.
- The 700 Series controller can be programmed to regenerate on specific days of the week.
- If electrical power is not available, the camshaft can be rotated counterclockwise by hand if the motor is removed.
- The 700 Series controllers send commands to the motor for camshaft movement. However, water pressure/flow are required during the regeneration cycle for backwash, purge and refill, and brine draw to actually take place.
- Make sure control power source is plugged in. The transformer should be connected to a non-switched power source.
- You can start programming at the beginning by resetting the control mode. When viewing H0 (History Value) push and hold SET for five seconds. The display reverts back to 255 and any programmed information is lost. Return to 700 Series Initial Power Up.

## LEVEL I PROGRAMMING

The 764 control can be quickly programmed by following the sequential procedure on pages 12-13. Level I program parameters are those that can be accessed by pressing the UP or DOWN buttons.

- Resin Volume Setting: Set to match the volume (cubic feet) of resin in the mineral tank.
- Time of Day: Includes PM indicator. Can be set to display as a 24-hour clock. See Level II programming.
- Day of Week: Set to actual day of week.
- Time of Regeneration: Fully adjustable. Default is 2:00 AM.
- Days Override: Range 0.5 to 99 days. Leave at 0 to disable.
- Salt Dosage: Set at pounds of salt per cubic foot of resin in the conditioner tank (268 conditioner only). For the 263 filter valve the salt dosage is replaced with backwash length and the setting is minutes of backwash.

**NOTE:** When the control is set up for a twelve-hour clock a PM indicator when the displayed time is in the PM hours. There is no AM indicator.

## LEVEL II PROGRAMMING

### P Values

Level II program parameters can be adjusted to fine-tune the conditioner's operation. The parameters are accessible by pressing and holding the UP and DOWN buttons until the control displays a "P" value.

**NOTE: The control must be in the home position to change settings. See Table 3 for Level II parameters.**

Typically the Level II parameters will not need to be adjusted as the default settings accommodate most applications. Contact your water treatment professional before attempting any programming.

**Table 2 Level II Parameters**

	Description	Range	Minimum Increments	Default	Units	Notes
P9	Units of Measure	0-1	1	{2}		0 = US 1 = Metric
P10	Clock Mode	0-3	1	{2}		0 = 12 hour clock; flow rate service display 1 = 24 hour clock; flow rate service display 2 = 12 hour clock; Time of Day service display 3 = 24 hour clock; Time of Day service display
P11	Service Interval	0-250	1	0	Months	Uses 30 days for each month; 0 = off
P12	Remote regeneration switch delay	3-250	1	60	Seconds	Time remote switch must be active to start regeneration.
P13*	Chlorine Generator Options (not used on "A" and "P" systems)	0-2	1	0		0 = No chlorine generator 1 = Salt check only 2 = Generate chlorine
P14*	Refill Rate	1-700	1	{1}	gpm x 100	
P15	Draw Rate	1-700	1	{1}	gpm x 100	
P16	Reserve Type (not used for alternating mode)	0-3	1	0		0 = Variable reserve delayed regeneration 1 = Fixed reserve delayed regeneration 2 = Variable reserve immediate regeneration 3 = Fixed reserve immediate regeneration
P17	Initial Average or Fixed Reserve (not used for alternating mode)	0-70	1	30	% of capacity	Depends on value entered in P16
P18	Flow Sensor Select	0-7	1	{1}		0 = Internal Magnum NHWB 1, 6 = 1" Autotrol turbine 2, 7 = 2" Autotrol turbine 3 = User defined K-factor 4 = User defined Pulse Equivalent 5 = Internal Magnum HWB Values 6 & 7 are for single turbine configurations on twin alternating systems
P19	K-Factor or Pulse Equivalent	1.00-99.99 0-9999	0.01 1	0.01 1		K-factor P18 = 3; Pulse Equivalent P18 = 4
Pr**	Refill First	0-1	1	0		0 = Refill first off 1 = Refill first on
Pd	Remote Switch Operation	0-1	1	0		0 = Immediate Regeneration after P12 time 1 = Delayed Regeneration after P12 time
Notes: (1) Default selected with valve type and resin volume. (2) Factory Default is "0" for North America units and "1" for World units. * Not used for 273 filter valves. ** Not used when the control is programmed for twin alternating systems.						

## PROGRAMMING *CONTINUED*

### Programming the Lockout Feature

All Level I parameters can be locked out when the control is in Level II programming. Simply press the REGEN button during Level II programming and a Lock icon will appear indicating that the specific setting has been locked out. When locked out, the setting cannot be adjusted. To disable the lockout feature, press the REGEN button when in Level II. The Lock icon will not be displayed.

### Salt Setting

The default P6 salt setting is set at 9 lbs/ft<sup>3</sup>. Under normal circumstances this setting will provide the correct system capacity. This setting may be adjusted to change the exchange capacity (see Table 4).

**Table 3 High Efficiency Exchange Capacity**

Salt lbs/ft <sup>3</sup>	Exchange Capacity grains/ft <sup>3</sup>	Salt grams/liter	Exchange Capacity grams/liter
3	14100	50	33.6
4	18307	60	40.0
5	21160	70	44.5
6	23490	80	48.4
7	25460	90	51.8
8	27167	100	54.9
9	28673	110	57.7
10	30019	120	60.2
11	31238	130	62.6
12	32350	140	64.8
13	33373	150	66.8
14	34320	170	70.4
15	35202	200	75.2
16	36027	230	79.3
17	36802	260	82.9
18	37533	290	86.1

## LEVEL III CYCLE PROGRAMMING

### C Values

Several Level III program parameters can be adjusted to fine-tune valve operation for non-standard applications. Typically these parameters will not need to be adjusted as the default settings accommodate most applications. Contact your water treatment professional before attempting any programming.

The parameters are accessible by pressing and holding the UP and SET buttons until the display shows a "C" value.

**NOTE: The control must be in the treated water position to change settings.**

**Table 4 Level III Parameters**

C#	Description	Range	Minimum Increments	Default Setting	Notes
C1	Backwash	0-200	1 Min	10	Flow rate dictated by size of drain line flow controller.
C2	Regenerant Draw	0-200*	1 Min	See Notes	Automatically calculated from resin volume and salt dosage settings.
C3	Slow Rinse	0-200	1 Min	See Notes	Automatically calculated from resin volume and salt dosage settings.
C4	Re-pressurization	0-200	1 Min	3	Allows system to equalize water pressure across valve discs.
C5	Fast Rinse	0-200	1 Min	4	Rinses residual regenerant from tank.
C8	Regenerant Refill	0-200*	1 Min	See Notes	Automatically calculated from resin volume and salt dosage settings.
* C2 and C8 are automatically calculated and not adjustable when 268 softener is selected. C2 and C8 are adjustable when 273 filter is selected but are not used by the system.					

## LEVEL IV VIEWING HISTORY

### H Values

Historical information can be viewed by pressing the SET and DOWN buttons simultaneously, with the 764 control in the home position. Release both buttons when the control displays an "H" value. Press the UP or DOWN buttons to navigate to each setting.

**Table 5 History Data**

H#	Description	Range	Notes
H0*	Initial Setting Value	Cubic Feet or Liters	Resin Volume
H1	Days since last regeneration	0-255	
H2	Current Flow Rate	Depends on turbine used	
H3	Water used today in gallons or m <sup>3</sup> since Time of Regeneration	0-131,070 gallons or 0-1,310.70 m <sup>3</sup>	
H4	Water used since last regeneration in gallons or m <sup>3</sup>	0-131,070 gallons or 0-1,310.70 m <sup>3</sup>	
H5*	Total water used since reset in 100s	0-999900 gallons or 0-9999 m <sup>3</sup>	
H6*	Total water used since reset in 1,000,000	4,294 x 10 <sup>6</sup> gallons or 4,264 x 10 <sup>4</sup> m <sup>3</sup>	
H7	Average usage for Sunday in gallons or m <sup>3</sup>	0-131,070 gallons or 0-1,310.70 m <sup>3</sup>	
H8	Average usage for Monday in gallons or m <sup>3</sup>	0-131,070 gallons or 0-1,310.70 m <sup>3</sup>	
H9	Average usage for Tuesday in gallons or m <sup>3</sup>	0-131,070 gallons or 0-1,310.70 m <sup>3</sup>	
H10	Average usage for Wednesday in gallons or m <sup>3</sup>	0-131,070 gallons or 0-1,310.70 m <sup>3</sup>	
H11	Average usage for Thursday in gallons or m <sup>3</sup>	0-131,070 gallons or 0-1,310.70 m <sup>3</sup>	
H12	Average usage for Friday in gallons or m <sup>3</sup>	0-131,070 gallons or 0-1,310.70 m <sup>3</sup>	
H13	Average usage for Saturday in gallons or m <sup>3</sup>	0-131,070 gallons or 0-1,310.70 m <sup>3</sup>	
H14	Average service cycle	0-255 days	
H15*	Peak Flow Rate	0-200 gpm or 1000 Lpm	
H16	Day and Time of Peak Flow Rate	Time and day that peak flow occurred	
H17*	Months since service	0-2,184 months	
H18	Water used since last regeneration - Tank 1	0-131,070 gallons or 0-1,310.70 m <sup>3</sup>	
H19*	Water used since last regeneration - Tank 2	0-131,070 gallons or 0-1,310.70 m <sup>3</sup>	
Hr	Number of regenerations since last service	0-65536	
* H0, H5, H6, H15, H17, H19 values can be reset by pressing and holding  for three seconds while the value is being displayed.			

## REFILL-FIRST OPTION

---

Refill First is only available for single tank "L" and twin parallel "P" systems.

The 764 control allows users to select when the refill cycle occurs. When Pr = 0 (default) refill occurs immediately after fast rinse. When Pr = 1 refill will not occur until just before a regeneration. This allows for a "dry" brine tank.

If refill first is selected, the valve will move to refill two hours before the start of backwash. After refill is complete, the valve moves back to service for a two-hour brine make-up time. Regeneration then follows as normal, skipping refill.

By default, time of regeneration is set to midnight after refill first is selected.

**NOTE: The tank in service (on-line) cannot be regenerated while the other tanks are isolated. Water for backwash would not be available.**

## MANUAL REGENERATION OPTIONS

---

The 764 control features several options that offer additional flexibility for manually regenerating the conditioner. On alternating systems the tank in standby will move through regeneration to service. The tank in service will move through regeneration to standby. On parallel systems, the tank with the lowest remaining capacity will regenerate.

### Delayed Manual Regeneration

Press and release the REGEN button to start a delayed manual regeneration. The Regeneration icon on the display will flash indicating a regeneration will start when the time of day reaches the programmed time of regeneration. Pressing the REGEN button again will turn off the regeneration icon and cancel the delayed regeneration.

### Immediate Manual Regeneration

Pressing and holding the REGEN button for three seconds starts an immediate manual regeneration. A solid regeneration icon will be displayed. The control will immediately begin a regeneration on the tank in service.

### Delayed Second Regeneration

Pressing and releasing the REGEN button while the control is in regeneration will program the control for a delayed second regeneration. A flashing x2 icon next to the regeneration icon will appear, indicating a second regeneration will start when the time of day reaches the programmed time of regeneration. The delayed second regeneration will be performed on the new tank in service. For alternating and parallel systems, each tank will regenerate once.

### Double Immediate Manual Regeneration

Back-to-back manual regenerations are initiated by pressing and holding the REGEN button for three seconds while the control is in the regenerating mode. A solid x2 icon next to the regeneration icon will appear indicating a second manual regeneration will start immediately after current regeneration is complete. For alternating and parallel systems each tank will regenerate once. Single tank systems will regenerate twice back-to-back.

### During a Regeneration

- A "C#" is displayed to show the current cycle.
- Total regen time remaining is displayed on the screen.
- Press and hold SET to show the current cycle time remaining.

## To Advance Regeneration

1. Press and hold SET - showing current cycle time.
2. Simultaneously press SET and UP to advance on the cycle. An hourglass will display while the cam is advancing. When the cam reaches the next cycle, "C2" will be displayed.
3. Repeat SET and UP to advance through each cycle.
4. Press and hold SET and UP for five seconds to cancel the regen. An hourglass will flash once cancelled. The camshaft will advance to home, this may take one to two minutes.

## Viewing Cycle Times

1. Press and hold the UP and SET buttons for three seconds when the control is in the "in service mode" to access the "cycle time display mode". The display will show a small "c" followed by a number in the lower portion of the display.
2. Press the UP and DOWN buttons to display the programmed cycle time.
3. Press the REGEN button to exit the "cycle times display mode".

## PROGRAM RESET

---

The 764 control can be reset to original factory parameters when viewing the H0 parameter. Press and hold SET and DOWN simultaneously for five seconds. H0 and the system's set resin volume (or "F" mode) will be displayed. Press and hold the SET button for three seconds while H0 is displayed. Release the button. All settings except for Time of Day and Day of Week will be reset. The 764 Logix control will now display the valve and system type. Refer to Level I programming.

**NOTE: After any control reset (valve type or system change, etc.) it is necessary to initiate a manual regeneration and quick cycle through it. This will ensure the control and cam are synchronized. If not synchronized Err# will display and the control will drive cams to the correct position for valve and system type programmed.**

# REGENERATION MODES FOR PARALLEL SYSTEMS

Parameter P16 is used to determine the method for demand initiated regeneration. Four regeneration modes are possible.

- **P16 = 0: Delayed Regeneration with a Smart Reserve**

Regenerations will start only at the time of regeneration entered in P2. A tank is regenerated if the capacity remaining in that tank is below the minimum required capacity needed to meet the next day's calculated water usage requirement. The next day's water usage number is based on the daily average water usage held in memory plus a 20% reserve. If necessary, both tanks will be regenerated sequentially, beginning with the most exhausted tank.

This option allows the control to vary the reserve, and therefore the decision to regenerate, based on the actual daily water usage pattern for the location at which it is installed. See Table 7.

- **P16 = 1: Delayed Regeneration with a Fixed Reserve**

Regenerations will start only at the time of regeneration entered in P2. A tank is regenerated if the capacity remaining in that tank is below the percentage entered in P17.

If either tank's capacity is overrun by 50% a regeneration will take place. The control will also cause both tanks to be regenerated sequentially, the next time of regeneration regardless of how much water is used during that 24 hour period. This feature is to help recover a severely exhausted bed. See Table 8.

- **P16 = 2: Immediate Regeneration - Fixed Reserve / Delayed Regeneration - Smart Reserve**

This option uses the features of both option 0 and option 3. This is the most versatile of regeneration options. Option number 2 provides all the advantages of variable reserve based on the actual amount of water that is used each day plus the capability to react to the excessive water usage days that occur occasionally. See Table 9.

- **P16 = 3: Immediate Regeneration - Fixed Reserve**

Regenerations are started immediately when a tank reaches zero or when the system capacity remaining (capacity remaining in both tanks) drops below the reserve capacity programmed in P17. To prevent hard water this reserve should be set large enough to provide conditioned water during the regeneration of the most exhausted tank. See Table 10.

Table 6 P16 = 0

Priority	Flow Rate	Continuous Soft Water	Efficiency
High	•		
Average		•	•
Low			

Table 7 P16 = 1

Priority	Flow Rate	Continuous Soft Water	Efficiency
High	•		
Average		•	
Low			•

Table 8 P16 = 2

Priority	Flow Rate	Continuous Soft Water	Efficiency
High		•	
Average	•		•
Low			

Table 9 P16 = 3

Priority	Flow Rate	Continuous Soft Water	Efficiency
High		•	•
Average			
Low	•		

## SERVICE AND MAINTENANCE

### Cover

The cover provides protection for the controller, wiring, and other components. This cover will be removed for most service and maintenance.

When installed, the cover provides NEMA 3 water protection. This protects from falling water up to 30 degrees from vertical.

To remove cover:

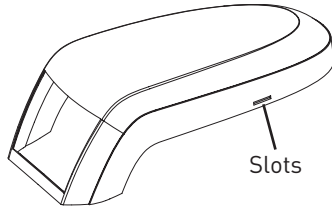

1. Grasp side edges toward rear of the valve.
2. Pull outwards until the slots in the cover clears the projections on the top plate.
3. Lift up on the rear and pull forward to clear the control module.

To install cover:

1. Position cover to be low in front and under the bottom edge of the control module.
2. The cover will hook on the bottom of the controller and drop down over the camshaft.
3. To finish, grasp the side edges and pull outward to clear the projections on the top plate.
4. Drop down until the cover snaps in place.

### Electronic Control Module

The purpose of the electronic control module is to control the regeneration cycle. The control module has several variations. When replacing the controller, use the same model or some functions may not work. This is an electronic controller that is programmable and uses input/output signals.

To remove control module:

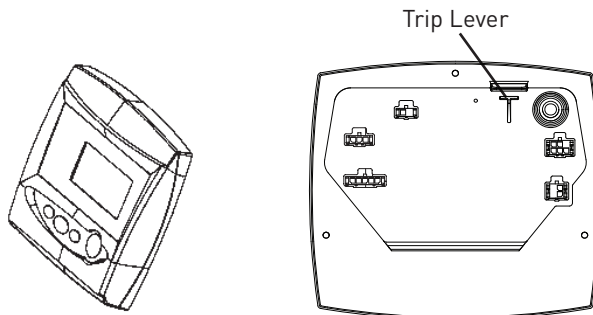

1. Disconnect power to the unit.
2. Remove valve cover.
3. Press trip lever to release module from top plate.
4. Pivot the top forward and up.
5. Remove any wire connections. Wire connectors have a locking tab that must be squeezed before removing.

**NOTE:** There is no need to label the wires. The keyed connectors will only plug back into one site.

To install control module:

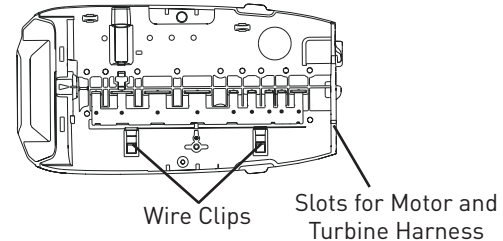

1. Be sure the power is disconnected.
2. Check model.
3. Check routing of wires and plug them into the controller. Connectors will snap in place. Be sure that wires are properly managed through the clips on top plate. This will prevent the wires from being caught in the camshaft.
4. Place bottom of module in position. The bottom will fit into a clip.
5. Pivot the top into position and snap in place. The controller should be secure.

If you are ready to program the controller, then power can be applied by plugging in transformer.

### Drive Motor

The drive motor is open loop and receives commands from the control module. The motor has a pinion gear that meshes with the camshaft gear to drive (rotate) the camshaft.

During operation, rotation forces the motor into its mounting position and screws or bolts are not needed.

**NOTE:** Some units will have a shipping peg in the top motor mount. The peg can be removed and discarded. This peg is not required for motor operation.

To remove motor:

1. Disconnect power to the unit.
2. Remove cover.
3. Pull off wiring connector.
4. Grasp the motor body and rotate counterclockwise.
5. Pull motor out.

To install motor:

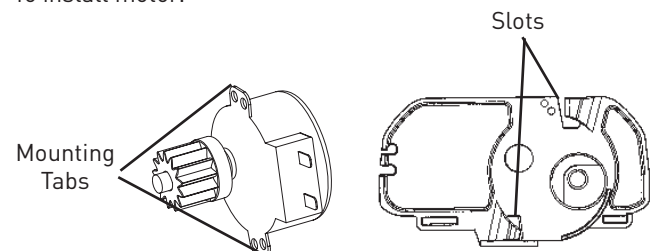

1. Insert gear through hole on top plate and mesh with camshaft. Cam may need to be rotated slightly.
2. With motor ears flat to the rear of the top plate, rotate clockwise until mounting tabs are engaged in slots.
3. Reconnect wires.

**NOTE:** It is not necessary to pre-position the camshaft or the motor. When the controller is powered up the camshaft will be rotated to the "home" position.

## SERVICE AND MAINTENANCE *CONTINUED*

### Optical Sensor

The optical sensor is mounted to the top plate. The camshaft cup rotates through the sensor and the slots are detected. A signal is sent to the controller for each slot.

**NOTE:** Damaged sensors should be replaced. Sensors may be cleaned with compressed air or a soft brush.

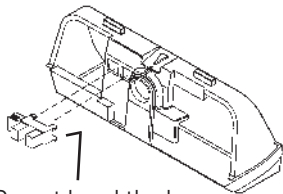

Do not bend the legs on the optical sensor.

To remove optical sensor:

1. Disconnect power to the unit.
2. Remove cover.
3. Remove controller.
4. From the controller side, pinch the legs of the sensor holder in the top plate.
5. Pull the holder away from the mounting surface.
6. Remove wires.

To install optical sensor:

1. Attach wires. Wires should point away from camshaft.
2. Place leading edge of sensor holder into opening.
3. Pivot holder into place. Legs should enter slots and snap in place.

**⚠ WARNING:** The optical sensor legs are fragile and may break. If the optical sensor legs break or crack, we recommend replacement. A damaged sensor may result in improper regeneration.

### Camshaft

The camshaft has several lobes that push open the valve discs as the camshaft rotates. Rotation is controlled by a drive motor that drives a gear at the rear of the camshaft. The front end has a cup with markings and slots.

**⚠ WARNING:** The camshaft slots are molded to exact dimensions. Do not attempt to modify the cam cup slots. Improper regeneration will occur!

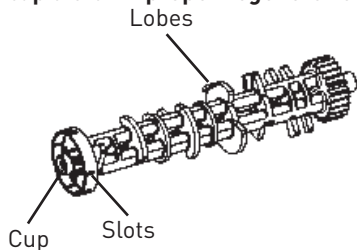

The outside surface of the cup has an arrow mark. When the arrow is at top center, the camshaft is in the loading position. 90 degrees clockwise on the cup an optical sensor is mounted to the top plate. This sensor reads the slots as they pass through. The largest slot is "Home" and the remaining slots are positioned to signal the regeneration cycles.

When looking at the end of the camshaft, numbers are visible in the hollow of the cup. An arrow on the top plate points to the current marking. The numbers represent regeneration cycles as follows:

- C0 = Treated water-normal operation mode
- C1 = Backwash
- C2 = Regenerant draw (not used in filter mode)
- C3 = Slow rinse (not used in filter mode)
- C4 = System pause
- C5 = Fast rinse cycle 1
- C8 = Regenerant refill (not used in filter mode)

These numbers are offset rotationally 90 degrees from the matching slot. The offset enables the service person to view the number at the top of the cup and determine which slot is at the optical sensor.

**NOTE:** If any part of the camshaft is broken or damaged the camshaft should be replaced. Do not repair or modify damaged cam lobes, gears or timing cup.

To remove camshaft:

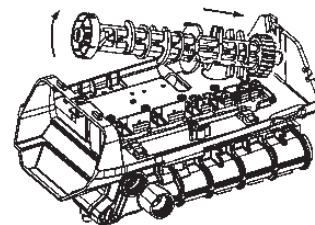

1. Disconnect power to the unit.
2. Remove cover.
3. Remove motor.
4. Camshaft should be in the treated water position. Rotate counterclockwise as needed.
5. Use a screwdriver to hold open the #1 valve disc.

**NOTE:** When replacing/removing camshaft, make sure not to damage or mis-align the optical sensor. Hold the sensor in position while removing camshaft.

6. Move the camshaft backwards, away from the controller.
7. Lift the loose front end up and out.

To install camshaft:

1. Check that the optical sensor is in position.
2. Position camshaft above the valve discs. The arrow on the cup should be up.
3. Slide the rear of the camshaft into place.
4. Pivot the camshaft close to its final position.
5. The camshaft will push on one or more valve discs. You will feel resistance as you complete the installation.
6. Move the camshaft down and into position. Force valve discs to move as needed.
7. Move the camshaft forward. Check that the optical sensor is in position.
8. Install motor.

**NOTE:** The camshaft will position itself to C0 (treated water) when the controller is powered up.

## SERVICE AND MAINTENANCE *CONTINUED*

### Wiring Harnesses

The wiring harnesses are designed to fit one way. The connectors are unique to the port they plug into. The wires are held in place by clips and the connectors latch in place. Do not run wires through holes in top plate.

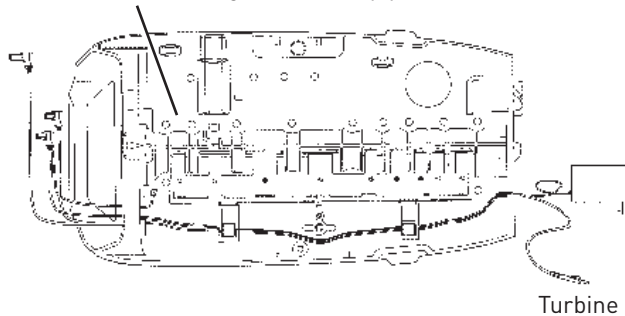
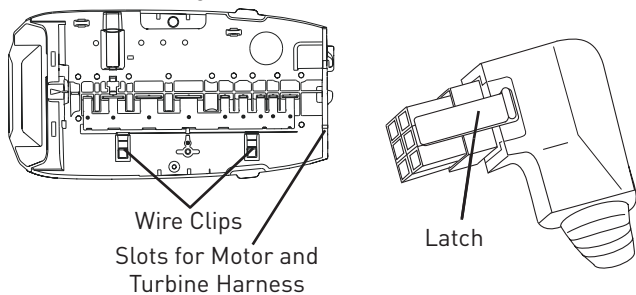

Figure 20 - Wire Harness Routing

To remove a wiring harnesses:



1. Disconnect power to the unit.
2. Remove cover.
3. Remove controller.
4. Remove connections by squeezing the latch on the connector and pulling out.
5. Pull the harness out of the clips on the top plate.

To install a wiring harness:

**NOTE:** Start at the back of the valve and work toward the controller. This will place any slack behind the controller. Slack or loose wires can become tangled in the camshaft.

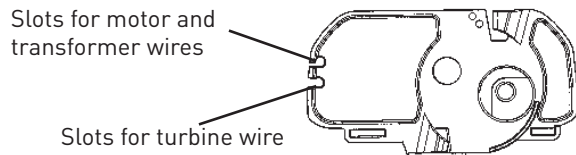

1. Depending on which harness is being installed, plug the connector into the motor or turbine.
2. Route the harness through the opening at the back of the top plate.
3. Place the harness into the clips on the top plate. Do not leave any slack. Put the motor wire in first, then the turbine sensor cable second.
4. Feed the wire through the opening on the front of the top plate.
5. If installing the motor harness the connector to the optical sensor can be clipped in place.
6. Connect the harness to the back of the controller.

**NOTE:** If using both a motor and turbine cable harness, install the smaller motor cable first. Install the larger turbine cable second. This will lock the motor cable beneath the wire management clips.

### Microswitch (Optional Under the Cover)

The microswitch is located under the cover and is screwed to the top plate. This switch is turned on/off by a cam lobe on the camshaft. Its function is to signal that the unit is in-service or out-of-service (regenerating).

Microswitches are available as kits from Pentair or a standard microswitch can be used as well.

**⚠ WARNING:** This switch will normally control an event on another piece of equipment. Be certain of what effect your actions will have on the other equipment.

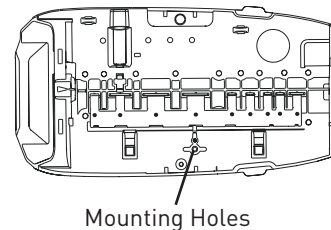

To install microswitch:

1. Connect wires.
2. Use self-tapping screws to secure the switch base to the blind boss top plate.
3. Adjust microswitch distance to cam.

**NOTE:** Proper procedure for replacing a self-tapping screw:  
**A.** Drop screw into hole.  
**B.** With a screwdriver, back the screw up (counterclockwise) until the threads click.  
**C.** Rotate the screw forward (clockwise) until finger tight.

**⚠ WARNING:** The valve is rated for low voltage (less than 48 volts) microswitch components only. Using a high voltage switch may result in damaged valves or fire and may interfere with electronic control function.

To remove microswitch:

1. Disconnect power to the switch.
2. Remove cover.
3. Unscrew switch base from top plate.
4. Disconnect wires.

### Microswitch (Optional - Front of Camshaft)

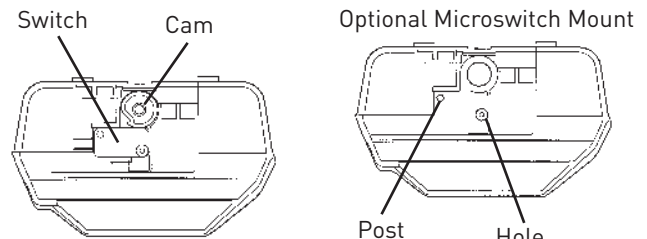

This microswitch is mounted behind the controller at the front end of the camshaft. The switch is mounted to the top plate. The cam for this switch is screwed to the front of the camshaft. This cam can be adjusted to activate the microswitch at any time during the regeneration cycle.

The front end cam switch is available as a kit from Pentair Water.

**⚠ WARNING:** This switch will normally control an event on another piece of equipment. Be certain of what effect your actions will have on the other equipment.

## SERVICE AND MAINTENANCE *CONTINUED*

To remove microswitch:

1. Disconnect power to the switch.
2. Remove cover.
3. Remove controller.
4. Unscrew switch from top plate.
5. Disconnect wires.

To install microswitch:

1. Connect wires.
2. Screw switch base to top plate using the switch guide pin over screw boss.
3. Attach the switch cam to front of the camshaft with a self-tapping screw. Adjust to the appropriate cycle and tighten.

**NOTE:** The cam for this switch is adjustable. To have the microswitch activate at a different point in the cycle, rotate the cam as needed. To rotate the cam loosen the center screw, tighten when the cam is in the new position.

### Spring (Valve Discs)

This spring is a one-piece metal spring that applies pressure to the valve discs holding them closed. The rotating camshaft overcomes this pressure to open the valve discs as needed. The shape of the spring is critical for proper operation.

**⚠ WARNING:** Do not attempt to straighten or repair this spring. If this spring is damaged, valve discs may not operate correctly.

To remove spring:

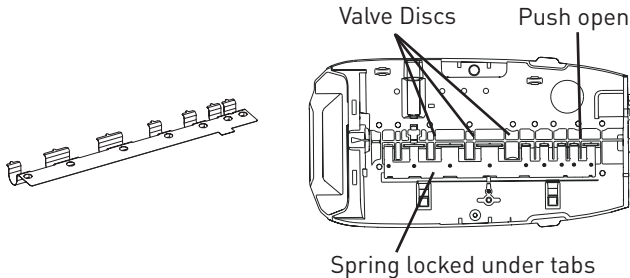

1. Disconnect power to the unit.
2. Remove cover.
3. Remove motor.
4. Remove camshaft.
5. Place unit in bypass.
6. Release water pressure by pushing the last valve discs open with a screw driver.
7. Locate valve discs 3, 4 and 5.
8. Position yourself on the spring side of the valve discs.
9. Place two (or more) fingers on the flat part of the spring.
10. Move the fingers toward the valve discs and into the spring valley between the previously located valve discs.
11. By pulling back and up on the spring, the spring will pop out of the valley.
12. Pull back further to remove the spring.

To install spring:

- 
1. Inspect the spring for damage. Do not attempt to repair a bent spring.
  2. Position yourself on the spring side of the valve discs.
  3. Position the spring over the valve body close to final position. The wide spring segments will be located at the wide valve discs. The curve of the spring will be down into the valley.
  4. The long flat close edge is inserted first. This edge slides into a channel on the valve body.
  5. Rock the spring back and place the flat edge into the channel.
  6. Lower the springs until they rest on top of the valve discs.
  7. A tool (phillips screwdriver) will be needed to push the springs in place.
  8. The spring posts will guide the spring into position.
  9. Hold the flat part down with one hand.
  10. Spread your fingers apart to cover the length and push down.
  11. With the other hand use the tool to push down in the valley of each spring segment.

The spring will slide off the top of the valve disc downward. The small projection on the end of the spring will drop into the hole in the valve disc to provide secure positioning. Repeat for all spring segments.

**NOTE:** If a spring segment goes beyond the locating hole, it can be pulled back using a small flat blade screwdriver.

**NOTE:** In high pressure (80 psi and higher) applications, the standard single valve disc springs can be installed on top of the one piece spring.

### Terminal Block (Optional)

**⚠ WARNING:** The Pentair Water valve is rated for low voltage microswitch components only. Using a high voltage switch may result in damaged valves or fire and may interfere with electronic control function.

Holes are provided to mount standard terminal blocks. The location is under the cover on the top plate.

Mounting Holes

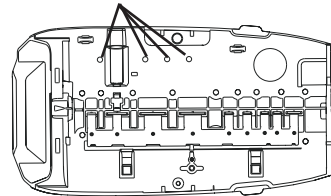

To install terminal blocks:

1. Disconnect power to unit.
2. Remove cover.
3. Use self-tapping screws to secure terminal block to top plate.
4. Clip wires with plastic tie-wrap to ensure that the wires do not tangle in camshaft.

## SERVICE AND MAINTENANCE *CONTINUED*

### Top Plate

The top plate holds the valve discs in place during operation. This plate is removed to allow cleaning and replacing the valve discs.

**NOTE:** The Pentair Water valve discs are made from a chloramine resistant severe service rubber. The valve discs will usually not need to be changed. Before removing the top plate for valve disc service be certain that one of the discs is not operating correctly.

To remove top plate:

Remove screws

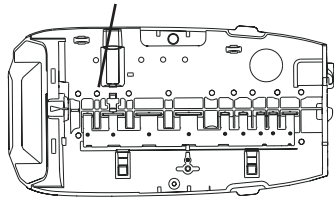

1. Disconnect power to unit.
2. Remove cover.
3. Remove motor.
4. Remove camshaft.
5. Place unit in bypass.
6. Release water pressure by pushing the last valve disc open with a screwdriver.
7. Any optional items may be removed.
8. Wiring harnesses should be removed.
9. Remove valve disc and spring.
10. Use a phillips screwdriver to remove the screws from the top plate.
11. Lift the top plate off. All the valve discs can be pulled straight out.

Inspect valve discs for wear. The sealing surface is the raised ridge on the underside of the top shoulder.

Check each valve disc cavity in the valve for debris. Remove any foreign objects before replacing the valve disc.

To install valve discs:

**NOTE:** If the valve disc fits properly in the cavity, it will work correctly.

1. Put the valve disc into the correct (based on shoulder size) valve port cavity. The metal end without rubber coating should be visible.
2. Push down on the shoulder to position the valve disc completely into the port cavity.
3. The metal portion will be positioned straight up and the top of the shoulder will be level with the valve.

To install the top plate:

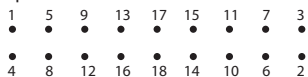

**NOTE:** All valve discs should be in position. Use the same screws that were removed to reassemble the top plate.

**⚠ WARNING:** Follow the procedure to engage the screws with the existing threads. If the same threads are not used, the holding power of the screw is lost. Under pressure the valve can leak. Screws that have the same diameter but have different threads should not be used.

1. Position the top plate on top of the valve and over the valve discs.
2. Insert a screw at one of the corner positions.

**⚠ WARNING:** This procedure for reinserting screws must be followed to ensure proper holding strength of the screws.

- A. Drop screw of same size and thread into the hole.
  - B. Use a phillips screwdriver and lightly rotate the screw backwards (counterclockwise).
  - C. When the thread of the screw and the thread of the hole match, the screw will "click" and slightly drop down.
  - D. The threads are lined up. Lightly rotate the screw to tighten and engage threads.
  - E. Once the threads have engaged the screw can be tightened. Minimal resistance will be present as the screw is turned in. Resistance indicates new threads are being formed. Back the screw out and rematch the threads.
3. Turn the screw in but do not tighten.
  4. Place a second screw into the hole diagonally opposite the first screw and turn in but do not tighten.
  5. Insert another screw into one of the remaining corners and turn it in.
  6. The fourth screw goes into the hole diagonally opposite. Turn it in.
  7. Put the remaining screws in following the same criss-cross pattern working from the ends toward the center. When all the screws are in place they can be tightened down.
  8. Start at the corner of the screw pattern and tighten that screw. Work the same pattern from the ends toward center and criss-crossing as each screw is tightened. Check that each valve disc moves smoothly before replacing the spring and camshaft.
  9. Replace spring.
  10. Replace camshaft and motor.
  11. Replace controller and wiring harnesses.

## **SERVICE AND MAINTENANCE CONTINUED**

### **Disinfection Of Water Conditioning Systems**

The materials of construction in the modern water conditioning system will not support bacterial growth, nor will these materials contaminate a water supply. During normal use, a conditioner may become fouled with organic matter, or in some cases with bacteria from the water supply. This may result in an off-taste or odor in the water.

Some conditioners may need to be disinfected after installation and some conditioners will require periodic disinfection during their normal life. Depending upon the conditions of use, the style of conditioner, the type of ion exchanger, and the disinfectant available, a choice can be made among the following methods:

#### **Sodium or Calcium Hypochlorite**

These materials are satisfactory for use with polystyrene resins, synthetic gel zeolite, and bentonites.

#### **5.25% Sodium Hypochlorite**

These solutions are generally known as household bleach. If stronger solutions are used, such as those sold for commercial laundries, adjust the dosage accordingly.

##### **1. Dosage**

- Polystyrene resin; 1.2 fluid ounce (35.5 mL) per cubic foot.
- Non-resinous exchangers; 0.8 fluid ounce (23.7 mL) per cubic foot.

##### **2. Regenerant tank conditioners**

- A. Backwash the conditioner and add the required amount of hypochlorite solution to the well of the regenerant tank. The regenerant tank should have water in it to permit the solution to be carried into the conditioner.
- B. Proceed with the normal regeneration.

#### **Calcium Hypochlorite**

Calcium hypochlorite, 70% available chlorine, is available in several forms including tablets and granules. These solid materials may be used directly without dissolving before use.

##### **1. Dosage**

- A. Two grains (approximately 0.1 ounce (3 mL) per cubic foot.

##### **2. Regenerant tank conditioners**

- A. Backwash the conditioner and add the required amount of hypochlorite to the well of the regenerant tank. The regenerant tank should have water in it to permit the chlorine solution to be carried into the conditioner.
- B. Proceed with the normal regeneration.

# WIRING DIAGRAMS

## Connecting the Logix 764 Twin Alternating or Parallel Controls

The twin sensor and extension cables are used for twin unit parallel and alternating applications. Four standard connections are required for operation; the power transformer, the flow sensor, motor/optical sensor, and the connection between tank 1 and tank 2 controls. Figure 21 outlines these standard features.

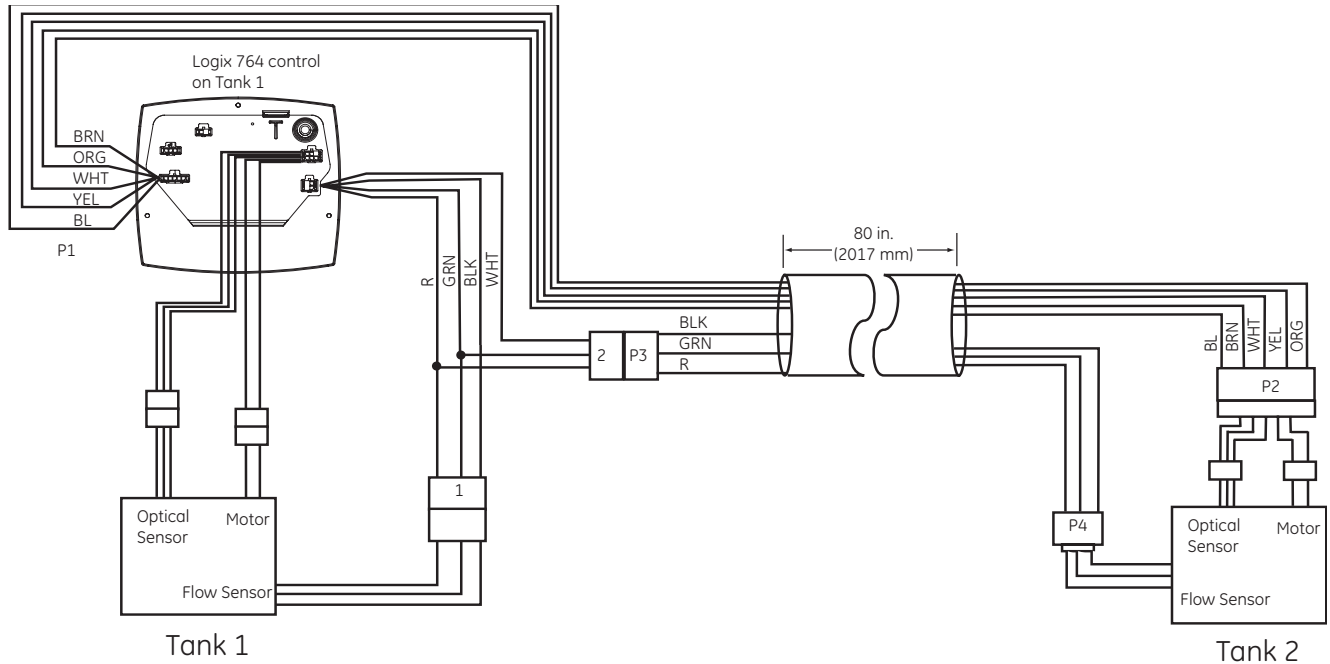

Figure 21

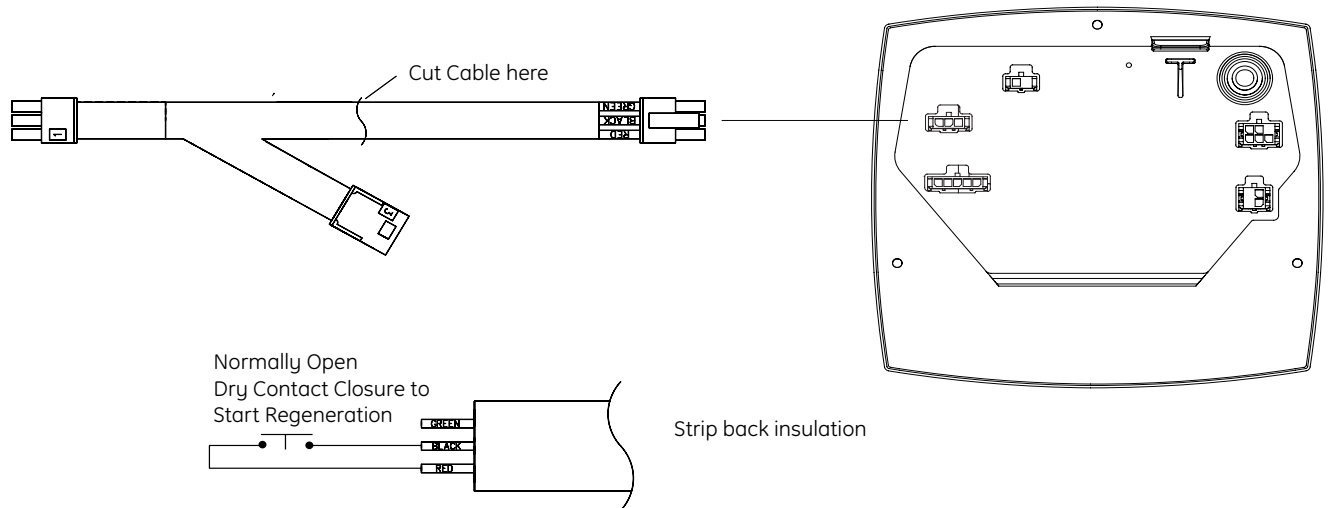

Figure 22

**NOTE:** Cable PN 3020228 sold separatel

**WIRING DIAGRAMS** *CONTINUED*

**Connecting the Logix 764 Multi Single Tank Control**

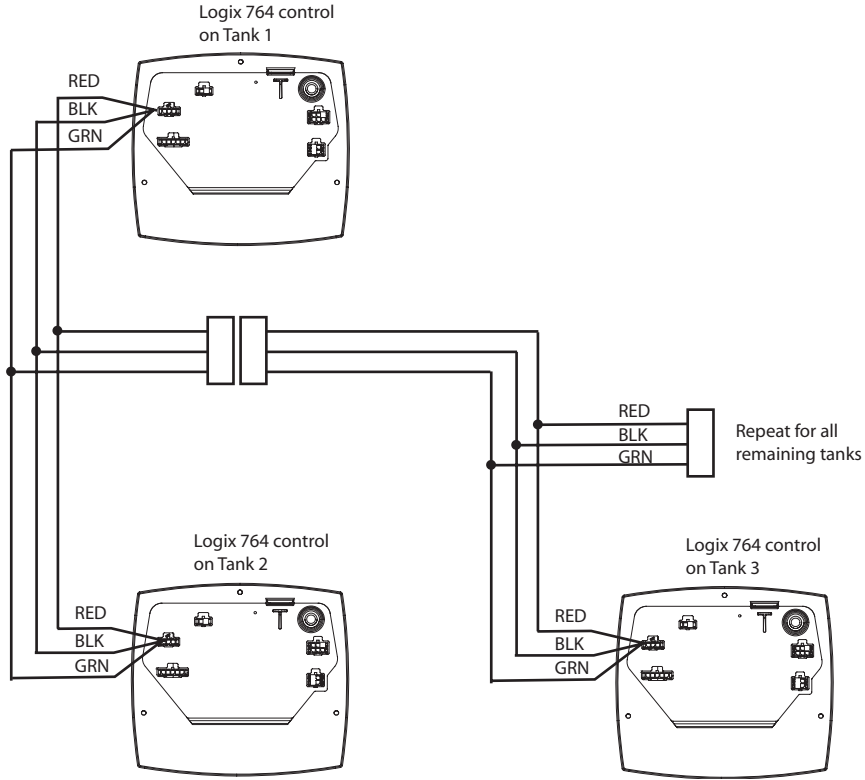
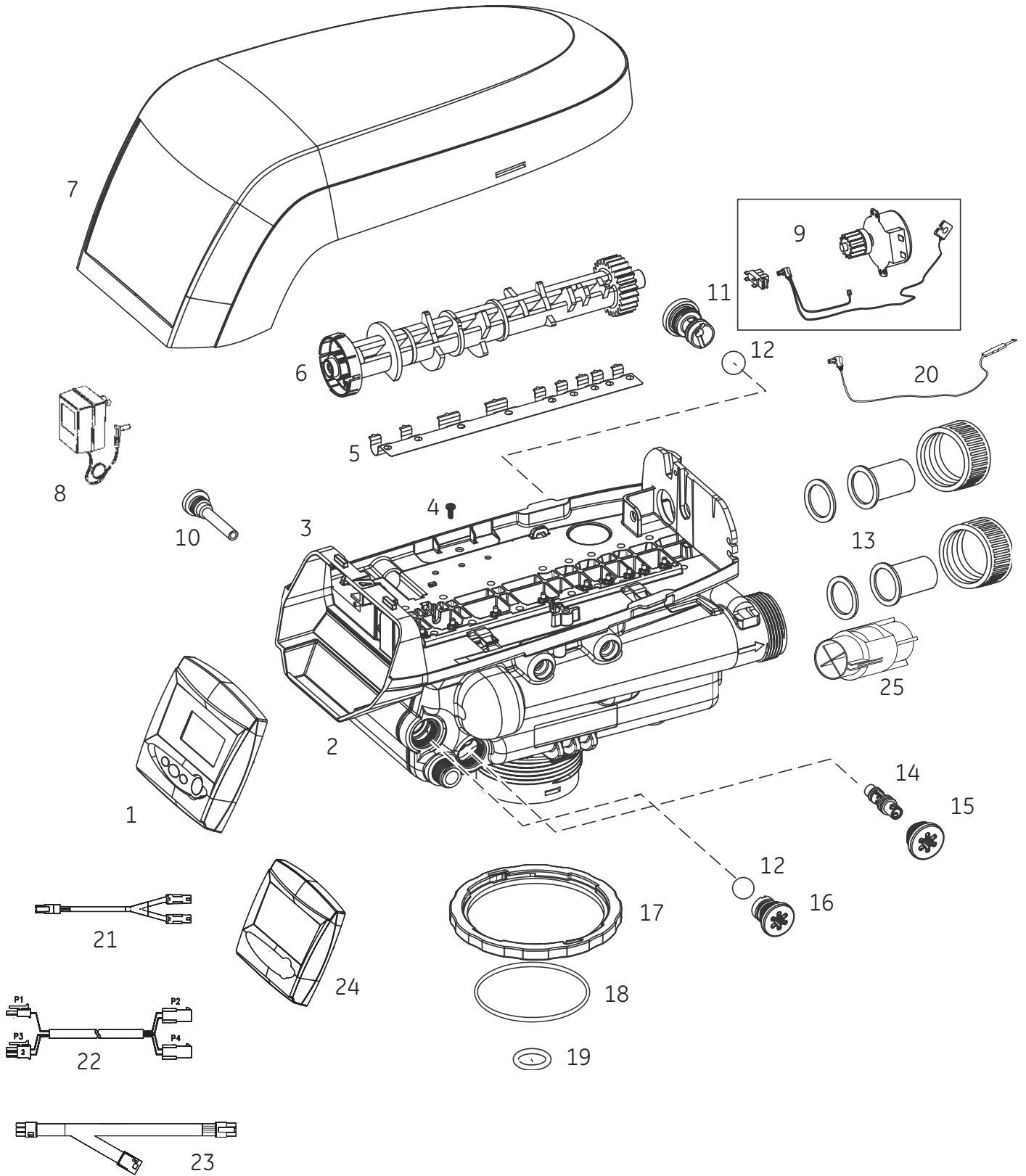

Figure 23

**NOTE:** Cable PN 3020228 sold separately.

# ASSEMBLY DIAGRAMS

## 273/278 Exploded View & Parts List



## ASSEMBLY DIAGRAMS *CONTINUED*

Item No.	QTY	Part No.	Description	Item No.	QTY	Part No.	Description
1	1		764 Series Control	22	1	3016775	Assy, Cable Extension 3 m (9.8 ft), Logix Twin
		3022004	278 Logix 764 Control w/Conditioner Faceplate Overlay - English	23	1	3020228	Assy, Cable Remote Start/ Multi-Tank Lockout, 3 m (9.8 ft)
		3022005	273 Logix 764 Control w/ Filter Faceplate Overlay - English	24	1	1254886	Secondary Faceplate
2	1	1244651	Valve Assembly w/o Flow Controls	25	1	1033444	Internal Turbine Assembly
3	1	1235338	Top Plate	*	1	1041174	Valve Disc Kit
4	12	1234170	Screw, Top Plate	*	1	1040930	1265 Bypass, Valve (Optional)
5	1	1235339	Valve Disc Spring, Performa Valve				
6	1	1237406	Cam, 278 Logix Valve, Twin				
7	1	1236246	Cover, Grey				
8	1	1000811	AC Adapter, North American				
9	1	3019221	Motor/Optical Cable				
10	1	1000226	Screen/Cap Assembly w/O-ring				
11	1		Drain Control Assembly				
		1000210	No. 8 (1.6 gpm; 6 Lpm)				
		1000211	No. 9 (2 gpm; 7.6 Lpm)				
		1000212	No. 10 (2.5 gpm; 9.5 Lpm)				
12	1	1030502	Ball, Flow Restrictor				
13	1		Adapter Kit, Multiple Options				
14	1		Injector				
		1035733	"H" Injector, Lt. Purple, 9-inch tank				
		1035734	"J" Injector, Lt. Blue, 10-inch tank				
		1035735	"K" Injector, Pink, 12-inch tank				
		1035737	"M" Injector, Brown, 14-inch tank				
		1035738	"N" Injector, Green, 16-inch tank				
		1035739	"Q" Injector, Purple, 18-inch tank				
		1035884	"R" Injector, Dark Grey, 21-inch tank				
15	1	1000269	Injector Cap with O-ring				
16	1	1243511	0.33 Refill Ball & Cone Type Flow Controller				
17	1	1035622	Tank Ring				
18	1	1010154	O-ring, Tank				
19	1	1232370	O-ring, Riser Tube				
20	1	1235446	Turbine Cable				
21	1	3016715	Assy, Sensor Cable Logix Twin				

\* Not shown in drawing.

## ASSEMBLY DIAGRAMS CONTINUED

### Bypass Valve

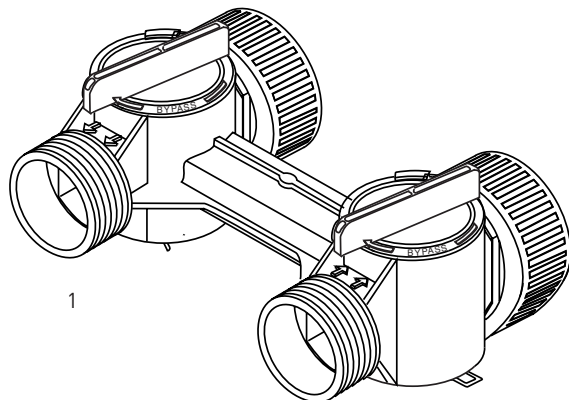

Item No.	QTY	Part No.	Description
1	1	1040930	1265 Bypass

# ASSEMBLY DIAGRAMS *CONTINUED*

## Manifold Kits

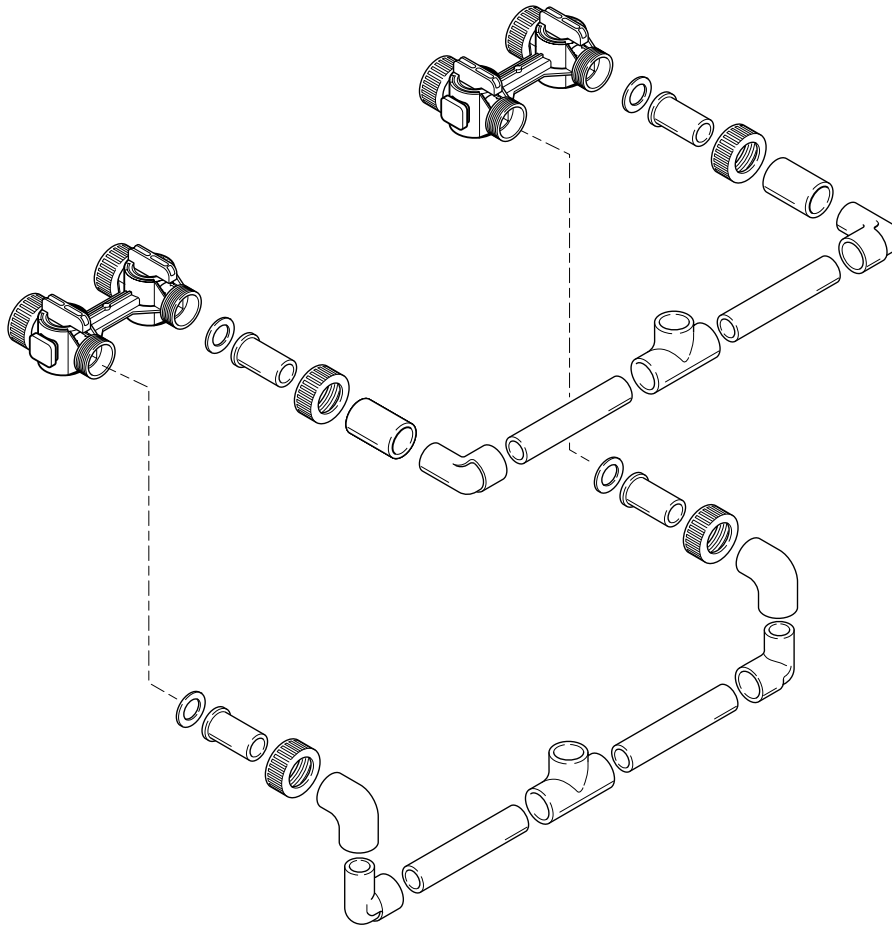

Item No.	QTY	Part No.	Description
.....	.....	3019933	273/278 Manifold Kit, 1-in, PVC w/1265 Bypass
.....	2	.....	Pipe Fitting, Tee, 1-in
.....	2	.....	Pipe Fitting, Elbow, Sch 40, 1-in, PVC
.....	4	.....	Pipe Fitting, Sch 40, 1-in, Str Elbow, PVC
.....	2	.....	Pipe Fitting, Sch 40, 1-in, Coupling, PVC
.....	4	.....	Gasket, 1.69 OD x 1.06 ID x 0.13 T, EP
.....	4	.....	Adapter Pipe, Soc Connector, 1-in, CPVC, Grey
.....	4	.....	Pipe, 1-in, Sch 40 x 12.5 in long, PVC, 255 Ry
.....	4	.....	Pipe-Tube Adapter Nut, 1.42 ID, Universal
.....	2	.....	1265 Bypass w/Install Kit, No Adapters, Single Pack

Item No.	QTY	Part No.	Description
.....	.....	3019932	74 Manifold Kit, 1-in PVC w/ No Bypass
.....	2	.....	Pipe Fitting, Tee, 1-in
.....	2	.....	Pipe Fitting, Elbow, Sch 40, 1-in, PVC
.....	4	.....	Pipe Fitting, Sch 40, 1-in, Str Elbow, PVC
.....	2	.....	Pipe Fitting, Sch 40, 1-in, Coupling, PVC
.....	4	.....	Gasket, 1.69 OD x 1.06 ID x 0.13 T, EP
.....	4	.....	Adapter Pipe, Soc Connector, 1-in, CPVC, Grey
.....	4	.....	Pipe, 1-in, Sch 40 x 12.5 in long, PVC, 255 Ry
.....	4	.....	Pipe-Tube Adapter Nut, 1.42 ID, Universal

# TROUBLESHOOTING

## 764 Controller - Error Codes & 278 "L" with Check Salt Light

Problem	Cause	Correction
ERR 1 is displayed	Program settings have been corrupted.	Press any key and reprogram Level I settings.
ERR 3 is displayed	Controller on tank 1 does not know the position of the camshaft. Camshaft should be rotating to find Home position.	Wait for two minutes for the controller to return to Home position. The hourglass should be flashing on the display indicating the motor is running.
	Camshaft on tank 1 is not turning during ERR 3 display.	Check that motor is connected.
		Verify that motor wire harness is connected to motor and controller module.
		Verify that optical sensor is connected and in place.
		Verify that motor gear has engaged cam gear.
	If everything is connected, try replacing in this order: —Wire harness, Motor and Optical Sensor Assembly —Controller	
Camshaft on tank 1 is turning for more than five minutes to find Home position:	Verify that optical sensor is in place and connected to wire.	
	Verify that camshaft is connected appropriately.	
	Verify that no dirt or rubbish is clogging any of the cam slots.	
	If motor continues to rotate indefinitely, replace the following components in this order: —Wire harness, Motor and Optical Sensor Assembly —Controller	
Regeneration starts but control shows Err3 before completing regeneration	Verify that the correct valve is selected in the Logix controller.	
ERR 4 is displayed	If single tank system...	Verify system setting is programmed to 273/278 "L".
	Controller on tank 2 does not know the position of the camshaft. Camshaft should be rotating to find Home position.	Wait for two minutes for the controller to return to the Home position. The hourglass should be flashing on the display indicating the motor is running.
	Camshaft on tank 2 is not turning during ERR 4 display.	Check that motor is connected.
		Verify that motor wire harness is connected to motor and controller module.
		Verify that optical sensor is connected and in place.
		Verify that motor gear has engaged cam gear.
If everything is connected, try replacing in this order: —Wire harness, Motor and Optical Sensor Assembly —Controller		
Camshaft on tank 2 is turning more than five minutes to find Home position.	Verify that optical sensor is in place and connected to wire.	
	Verify that camshaft is connected appropriately.	
	Verify that no dirt or rubbish is clogging any of the cam slots.	
	If motor continues to rotate indefinitely, replace the following components in this order: —Wire harness, Motor and Optical Sensor Assembly —Controller	
Four dashes displayed: -- : --	Power failure occurred	Press SET to reset the time display.
Check Salt Light is displayed - Press the regen button to turn off the check salt light.	No regenerant draw or insufficient regenerant detected during regeneration.	Ensure salt/regenerant is available. Check for regenerant draw. Inspect regenerant line for leaks.

## **TROUBLESHOOTING** *CONTINUED*

### **System Troubleshooting**

<b>Problem</b>	<b>Cause</b>	<b>Correction</b>
Regenerant tank overflow.	Uncontrolled refill flow rate.	Remove brine control to clean ball and seat.
	Air leak in regenerant line to air check.	Check all connections in regenerant line for leaks. Refer to instructions.
	Drain control clogged with resin or other debris.	Clean drain control.
Flowing or dripping water at drain or regenerant line after regeneration.	Valve stem return spring weak.	Replace spring. (Contact dealer.)
	Debris is preventing valve disc from closing.	Remove debris.
Hard water leakage after regeneration.	Improper regeneration.	Repeat regeneration after making certain correct regenerant dosage was set.
	Leaking of external bypass valve.	Replace bypass valve. (Contact dealer.)
	O-ring around riser pipe damaged.	Replace o-ring. (Contact dealer.)
	Incorrect capacity.	Verify appropriate regenerant amount and system capacity. (Contact dealer.)
Control will not draw regenerant.	Low water pressure.	Make correct setting according to instructions.
	Restricted drain line.	Remove restriction.
	Injector plugged.	Clean injector and screen.
	Injector defective.	Replace injector and cap. (Contact dealer.)
	Valve disc 2 and/or 3 not closed.	Remove foreign matter from disc and check disc for closing by pushing in on stem. Replace if needed. (Contact dealer.)
	Air check valve prematurely closed.	Put control momentarily into brine refill, C8. Replace or repair air check if needed. (Contact dealer.)
Control will not regenerate automatically.	AC adapter or motor not connected.	Connect power.
	Defective motor.	Replace motor. (Contact dealer.)
Control regenerates at wrong time of day.	Controller set incorrectly.	Correct time setting according to instructions.
Valve will not draw regenerant.	Low water pressure.	Set pump to maintain 20 psi at softener.
	Restricted drain line.	Change drain to remove restriction.
	Injector plugged.	Clean injector and screen.
	Injector defective.	Replace injector. (Contact dealer.)
Intermittent or irregular regenerant draw.	Low water pressure.	Set pump to maintain 20 psi at conditioner.
	Defective injector.	Replace injector. (Contact dealer.)
No conditioned water after regeneration.	No regenerant in regenerant tank.	Add regenerant to regenerant tank.
	Injector plugged.	Clean injector and screen.
	Air check valve closes prematurely.	Put control momentarily into brine/slow rinse, C2. Replace or repair air check if needed. (Contact dealer.)
Backwashes or purges at excessively low or high rate.	Incorrect drain controller used.	Replace with correct size controller. (Contact dealer.)
	Foreign matter affecting valve operation.	Remove drain controller and clean ball and seat.
Run out of conditioned water between regenerations.	Improper regeneration.	Repeat regeneration, making certain that correct regenerant dosage is used.
	Incorrect hardness or capacity settings.	Set to correct values. See Programming section.
	Water hardness has increased.	Set hardness to new value. See Programming section.
	Restricted meter turbine rotation due to foreign material in meter.	Remove meter housing, free up turbine and flush with clean water. Turbine should spin freely; if not, replace meter. (Contact dealer.)

## **TROUBLESHOOTING** *CONTINUED*



---

<b>Problem</b>	<b>Cause</b>	<b>Correction</b>
Regenerant tank overflow.	Regenerant valve disc 1 being held open by foreign matter.	Manually operate valve stem to flush away obstruction.
	Valve disc 2 not closed during regenerant draw causing brine refill.	Flush out foreign matter holding disc open by manually operating valve stem.
	Air leak in regenerant line to air check.	Check all connections in regenerant line for leaks. Refer to instructions.
	Improper drain control for injector.	Too small of a drain control with a larger injector will reduce draw rates.
	Drain control clogged with resin or other debris.	Clean drain control.

# FLOW DIAGRAMS



## Performa Valve

### Service Position

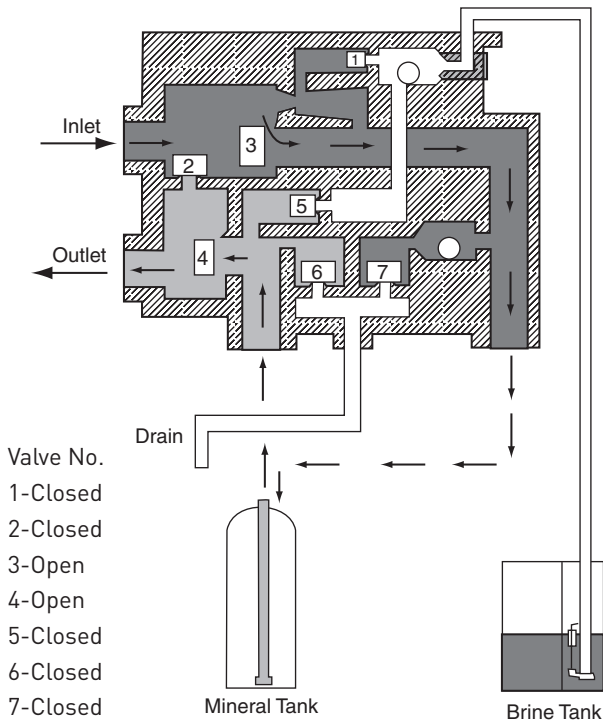
-  Hard Water
-  Soft Water



### Brining/Slow Rinse Position

-  Hard Water
-  Soft Water

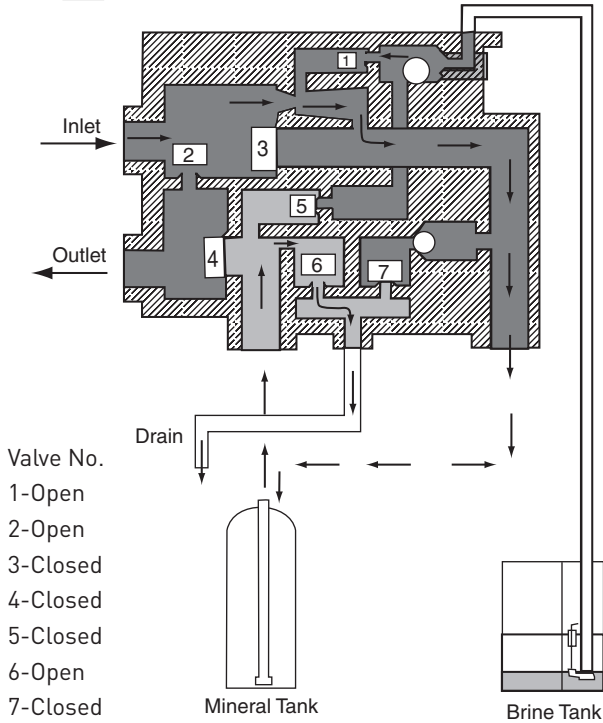

### Backwash Position

-  Hard Water
-  Soft Water

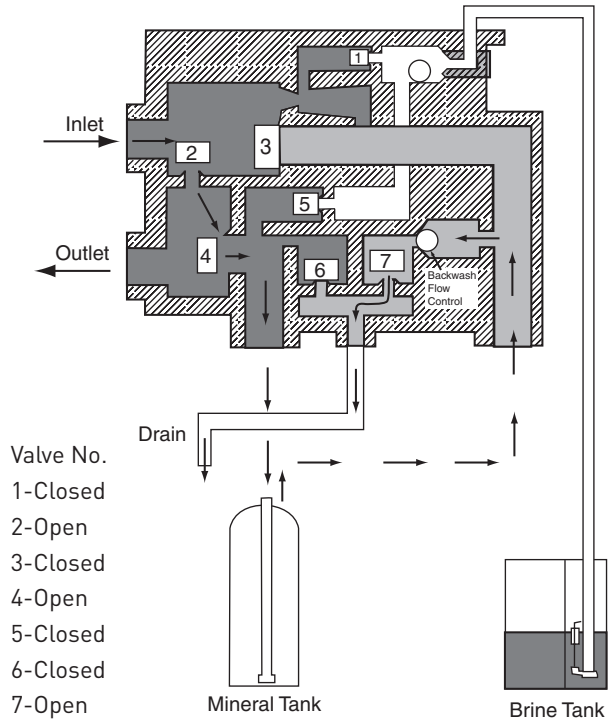

### Repressurize Position

-  Hard Water
-  Soft Water

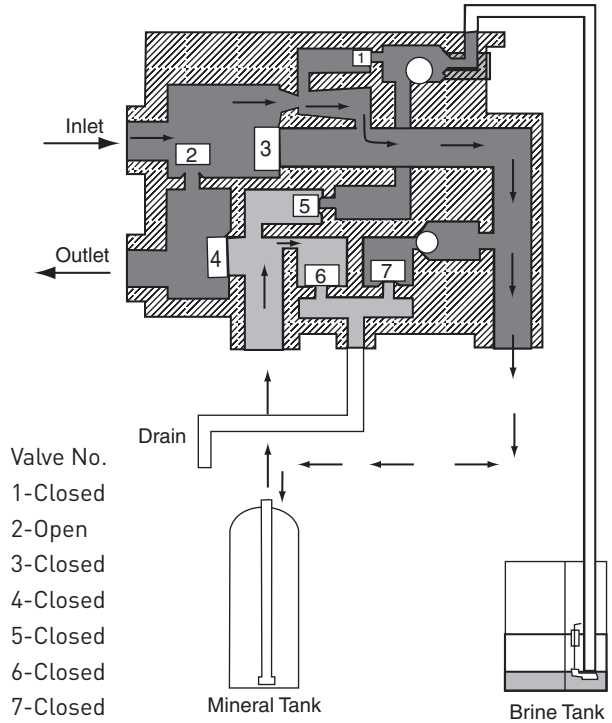

# FLOW DIAGRAMS CONTINUED

## Fast Rinse Position

Hard Water  
 Soft Water

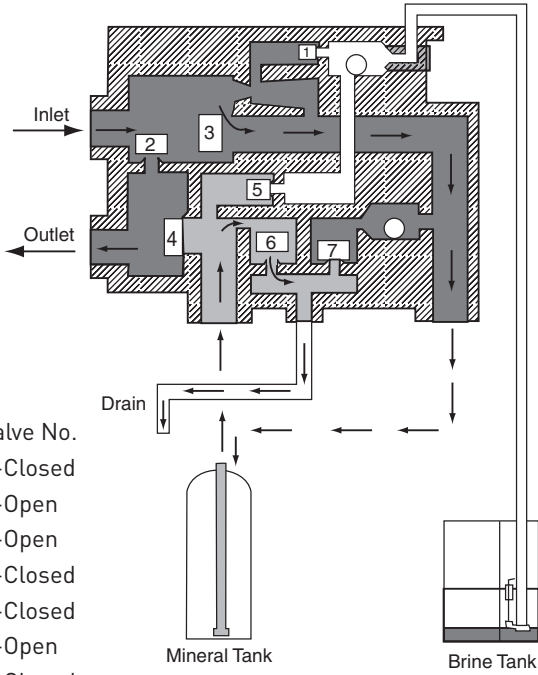

- Valve No.
- 1-Closed
  - 2-Open
  - 3-Open
  - 4-Closed
  - 5-Closed
  - 6-Open
  - 7-Closed

## Refill Position

Hard Water  
 Soft Water

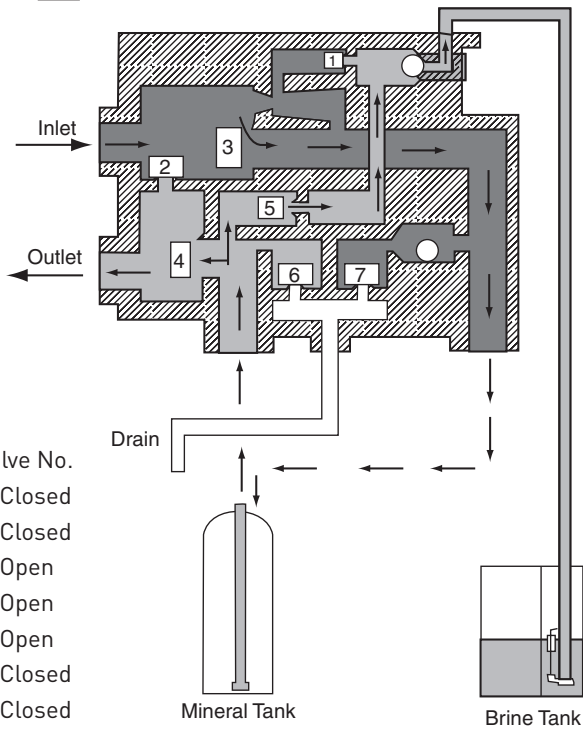

- Valve No.
- 1-Closed
  - 2-Closed
  - 3-Open
  - 4-Open
  - 5-Open
  - 6-Closed
  - 7-Closed

# FLOW DATA CHARTS

## Injector Performance Graphs

**Injector "H" (Light Purple)**  
For 9-inch Tanks

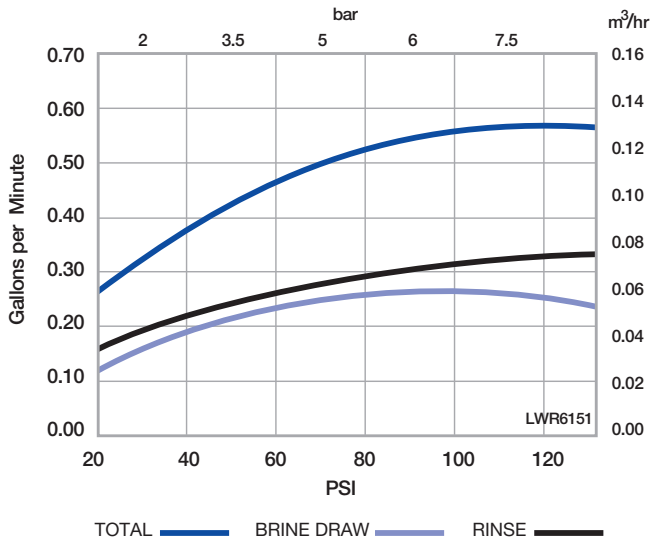

**Injector "K" (Pink)**  
For 12-inch Tanks

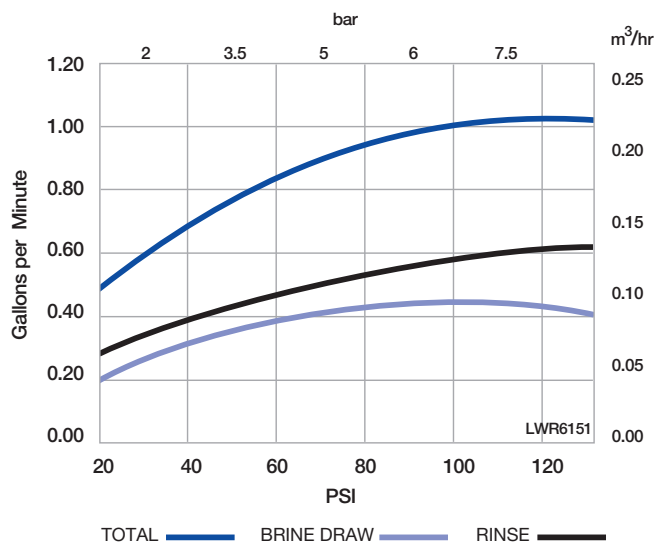

**Injector "J" (Light Blue)**  
For 10-inch Tanks

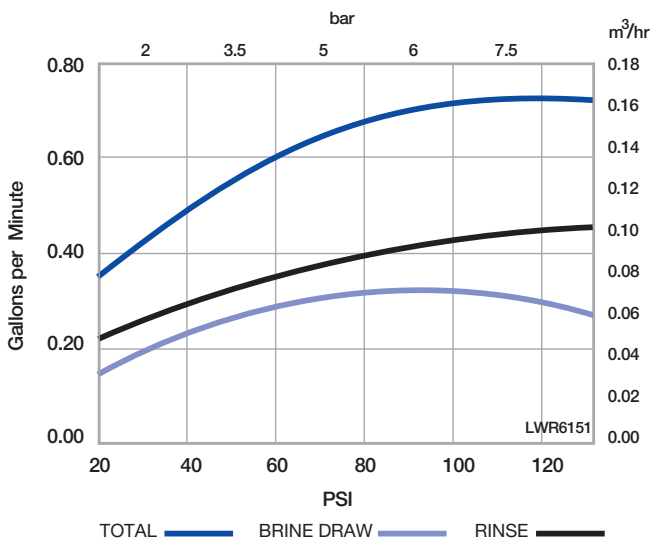

**Injector "L" (Orange)**  
For 13- and 14-inch Tanks

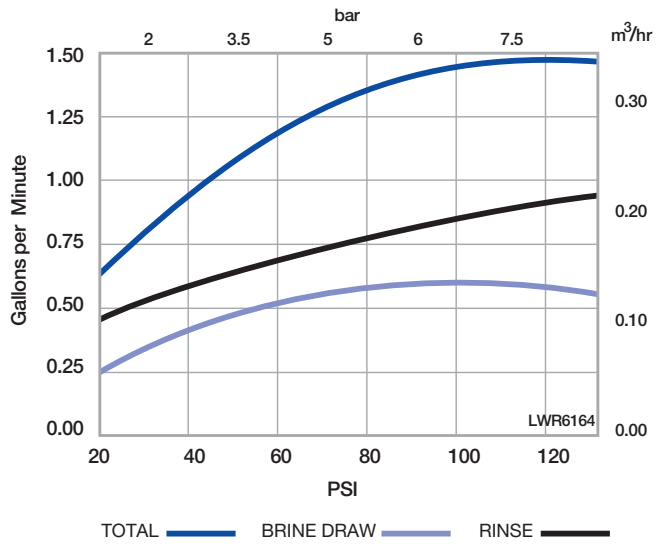

**FLOW DATA CHARTS *CONTINUED***

**Injector "N" (Green)  
For 16-inch Tanks**

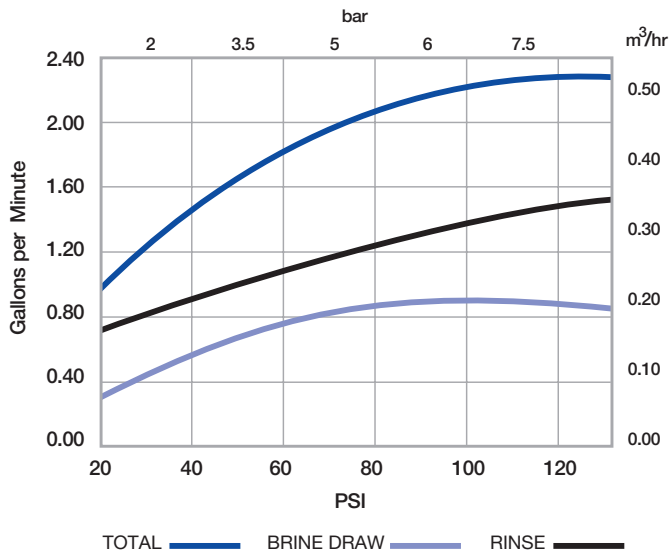

**Injector "R" (Dark Grey)  
For 21-inch Tanks**

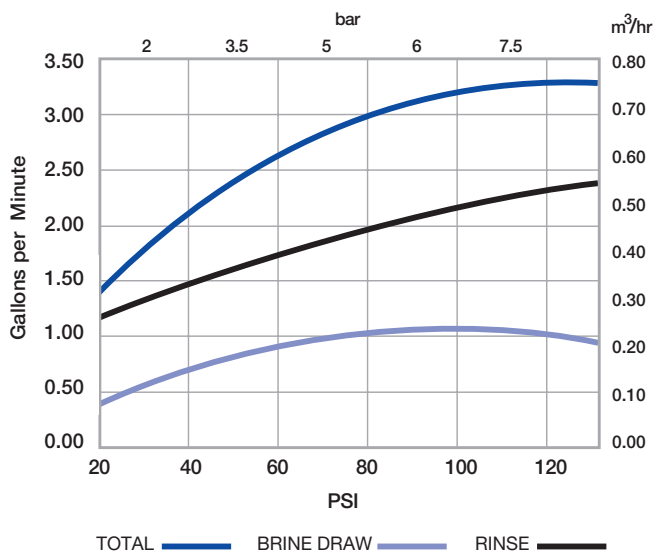

**Injector "Q" (Purple)  
For 18-inch Tanks**

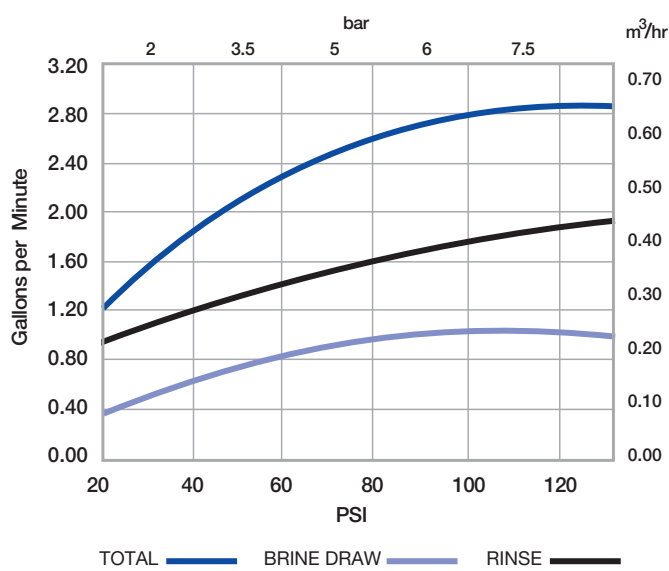

**Valve Flow Data**

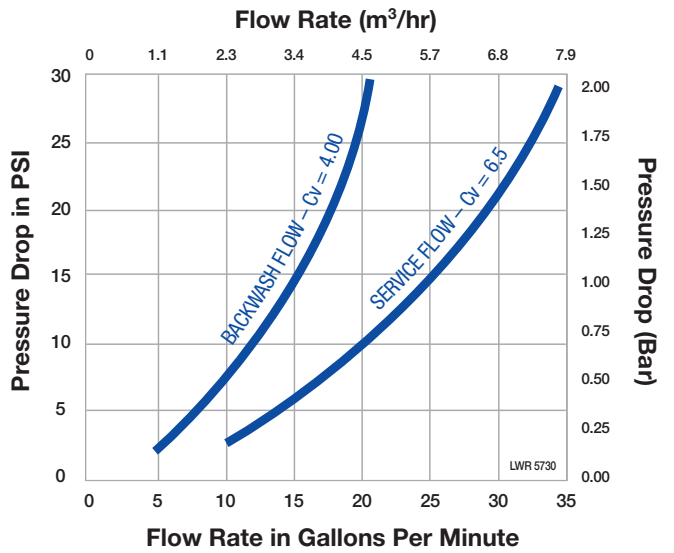





For Autotrol® Product Warranties visit:  
Autotrol® para las garantías de los productos visite: } [www.pentairaqua.com/pro](http://www.pentairaqua.com/pro)  
Pour Autotrol® garanties produit visitez le site :



**FILTRATION & PROCESS**

5730 NORTH GLEN PARK ROAD, MILWAUKEE, WI 53209

P: 262.238.4400 | [WWW.PENTAIRAQUA.COM](http://WWW.PENTAIRAQUA.COM) | CUSTOMER CARE: 800.279.9404 | [tech-support@pentair.com](mailto:tech-support@pentair.com)

All Pentair trademarks and logos are owned by Pentair, Inc. or its affiliates. All other registered and unregistered trademarks and logos are the property of their respective owners. Because we are continuously improving our products and services, Pentair reserves the right to change specifications without prior notice.

Pentair is an equal opportunity employer.

3020014 REV F JL14 © 2014 Pentair Residential Filtration, LLC All Rights Reserved.