

Owner's Manual

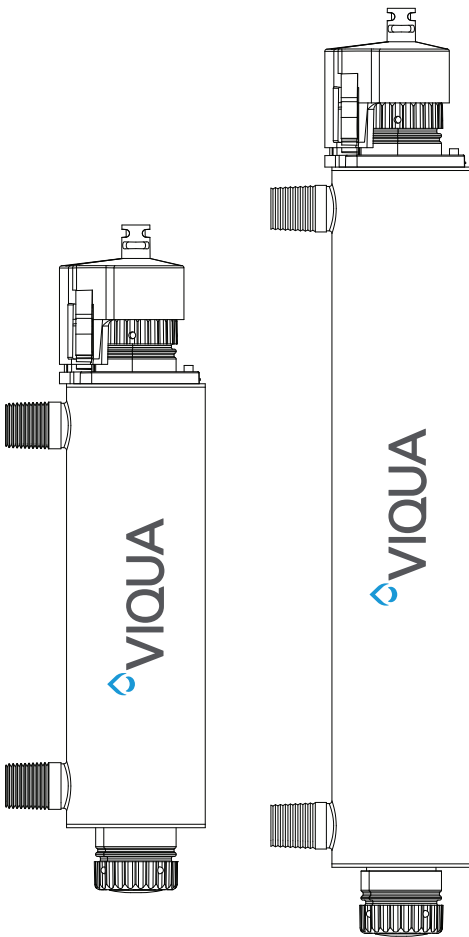

Powered by
Sterilight

Models:

VT1, VT1/2, VT1/2A, VT1/2B, VT1/12
VT4, VT4/2, VT4/2A, VT4/2B, VT4/12

Congratulations

on the purchase of your ultraviolet (UV) water disinfection system! This system uses the most advanced UV technology on the market and is designed to provide you with years of trouble free operation with minimal maintenance required to protect your drinking water from microbiological contaminants.

To ensure ongoing disinfection of your water, UV lamps need to be replaced annually with VIQUA factory-supplied replacements. VIQUA lamps are the result of extensive development resulting in a highly efficient disinfection platform with extremely stable UV output over the entire 9000 hour lifetime. Its success has led to a proliferation of non-genuine copies in the market.

The UV lamp is the heart of the disinfection system, and there should be no compromise when it's time for a replacement.

Why should you insist on genuine factory supplied VIQUA replacement lamps?

- Use of widely available, non-genuine, replacement lamps has been shown to damage the control module of VIQUA UV disinfection equipment.
- An increasing number of calls to VIQUA Technical Support are connected with non-genuine lamps being used (unknowingly) as replacements.
- Damage arising from the use of non-genuine lamps poses a safety risk and is not covered by equipment warranty.
- Unless the UV equipment is equipped with a UV sensor (monitor), it is not possible to verify the UV (invisible) output of replacement lamps.
- Similar appearance to the original lamp and the presence of (visible) blue light does not mean equivalent disinfection performance.
- VIQUA replacement lamps undergo rigorous performance testing and strict quality control processes to ensure that the safety and performance certifications of the original equipment are not compromised.

So, you can see that it's simply not worth the risk! Insist on genuine VIQUA replacement lamps.

















Section 1 Safety Information

These are the original instructions. Please read this entire manual before operating this equipment. Pay attention to all danger, warning, and caution statements in this manual. Failure to do so could result in serious personal injury or damage to the equipment.

Make sure that the protection provided by this equipment is not impaired. Do not use or install this equipment in any manner other than that specified in the installation manual.



1.1 Potential Hazards:

Read all labels and tags attached to the system. Personal injury or damage to the system could occur if not observed.

	Waste electrical and electronic equipment (WEEE). This symbol indicates that you should not discard wasted electrical or electronic equipment (WEEE) in the trash. For proper disposal, contact your local recycling/reuse or hazardous waste center.		This symbol indicates not to store any combustible or flammable material close to the system.
	This symbol indicates there is Mercury present.		This symbol indicates that the contents of the transport package are fragile and the package should be handled with care.
	This is the safety alert symbol. Obey all safety messages that follow this symbol to avoid potential injury. When on the equipment, refer to the Operational and Maintenance manual for additional safety information.		This symbol indicates safety glasses with side protection is required for protection against UV exposure.
	This symbol indicates a risk of electrical shock and/or electrocution exists.		This symbol indicates gloves must be worn.
	This symbol indicates the marked equipment may contain a component that can eject forcibly. Obey all procedures to safely depressurize.		This symbol indicates safety boots must be worn.
	This symbol indicates the system is under pressure.		This symbol indicates the operator must read all available documentation to perform required procedures.
	This symbol indicates there is a potential UV hazard. Proper protection must be worn.		This symbol indicates the plumber must use copper piping.
	This symbol indicates the marked item could be hot and should not be touched without care.		This symbol indicates that the system should only be connected to a properly grounded, grounding-type controller receptacle that is protected by a Ground Fault Circuit Interrupter (GFCI).
	This symbol indicates there is a potential for VERY hot water when flow is started.		

Warning: This product may contain chemicals known to the State of California to cause cancer and birth defects or other reproductive harm.

1.2 Safety Precautions:

⚠ DANGER	
 	<p>Failure to follow these instructions will result in serious injury or death.</p> <ul style="list-style-type: none"> Electric Shock: To avoid possible electric shock, special care should be taken since water is present near the electrical equipment. Unless a situation is encountered that is explicitly addressed by the provided maintenance and troubleshooting sections, do not attempt repairs yourself, refer to an authorized service facility. GROUNDING: This product must be grounded. If it should malfunction or breakdown, grounding provides a path of least resistance for electric current to reduce the risk of electrical shock. This system is equipped with a cord having an equipment-grounding conductor and a grounding plug. The plug must be plugged into an appropriate outlet that is properly installed and grounded in accordance with all local codes and ordinances. Improper connection of the equipment-grounding conductor can result in a risk of electrocution. Check with a qualified electrician or service personnel if you are in doubt as to whether the outlet is properly grounded. Do not modify the plug provided with this system – if it does not fit in the outlet, have a proper outlet installed by a qualified electrician. Do not use any type of adapter with this system. GROUND FAULT CIRCUIT INTERRUPTER PROTECTION: To comply with the National Electrical Code (NFPA 70) and to provide additional protection from the risk of electric shock, this system should only be connected to a properly grounded, grounding-type controller receptacle that is protected by a Ground Fault Circuit Interrupter (GFCI) or to a residual current device (RCD) having a rated residual operating current not exceeding 30 mA. Inspect operation of GFCI as per manufacturer's suggested maintenance schedule. DO NOT operate the disinfection system if it has a damaged cord or plug, if it is malfunctioning or if it has been dropped or damaged in any manner. DO NOT use this disinfection system for other than intended use (potable water applications). The use of attachments not recommended or sold by the manufacturer / distributor may cause an unsafe condition. DO NOT install this disinfection system where it will be exposed to the weather or to temperatures below freezing. DO NOT store this disinfection system where it will be exposed to the weather. DO NOT store this disinfection system where it will be exposed to temperatures below freezing unless all water has been drained from it and the water supply has been disconnected.

Safety Information

⚠ WARNING



- During extended periods of no water flow, the water in your chamber can become very hot (Approx. 60 °C) and potentially lead to scalding. It is recommended to run your water until this hot water has been purged from your chamber. Do not allow water to contact your skin during this time. To eliminate this condition, a temperature management valve can be installed at the outlet of your UV system.
- This system contains a UV Lamp. Do not operate the UV Lamp when it is removed from the chamber. Unintended use or damage of the system may result in the exposure of dangerous UV radiation. UV radiation may, even in little doses, cause harm to the eyes and skin.
- Changes or modifications made to this system without the consent of the manufacturer could render the system unsafe for operation and may void the manufacturer's warranty.

⚠ CAUTION



Failure to follow these instructions could result in minor or moderate injury.

- Carefully examine the disinfection system after installation. It should not be plugged in if there is water on parts not intended to be wet such as, the controller or lamp connector.
- Due to thermal expansion concerns and potential material degradation due to UV exposure, it is recommended to use metal fittings and at least 10" of copper pipe on the outlet of your UV chamber.
- **Hg EXPOSURE:** The UV lamp contains mercury. If the lamp breaks, then avoid inhalation or ingestion of the debris and avoid exposure to eyes and skin. Never use a vacuum cleaner to clean up a broken lamp as this may scatter the spilled mercury. Obey local regulations and guidelines for the removal and disposal of mercury waste.

NOTICE



- The UV lamp inside the disinfection system is rated at an effective life of approximately 9000 hours. To ensure continuous protection, replace the UV lamp annually.
- The UV system is not to be used or played with by children. Persons with reduced physical, sensory or mental capabilities, or lack of experience and knowledge, are also not to handle the UV system unless they have been given supervision or instruction.
- This system is intended to be permanently connected to the water lines.
- This system is not intended to be used in or above water or outdoors or used in swimming pools when persons are in the pool.
- **EXTENSION CORDS:** If an extension cord is necessary, use only 3-wire extension cords that have 3-prong grounding-type plugs and 3-pole cord connectors that accept the plug from this system. Use only extension cords that are intended for outdoor use. Use only extension cords having an electrical rating not less than the rating of the system. A cord rated for less amperes or watts than this system rating may overheat. Exercise caution when arranging the cord so that it will not be tripped over or pulled. Do not use damaged extension cords. Examine extension cord before using and replace if damaged. Do not abuse extension cord. Keep extension cord away from heat and sharp edges. Always disconnect the extension cord from the receptacle before disconnecting this system from the extension cord. Never yank cord to pull plug from outlet. Always grasp the plug and pull to disconnect.
- If the supply cord is damaged, it must be replaced by a special cord or assembly available from the manufacturer or its service agent.
- **SYSTEM PROTECTION:** To protect your Controller, a UL1449 certified (or equivalent) transient voltage surge suppressor is strongly recommended.
- The UV lamp in this system conforms to the applicable provisions of the Code of Federal Regulations (CFR) requirements including, Title 21, Chapter 1, Subchapter J, Radiological Health.
- Read and understand the Owner's Manual before operating and performing any maintenance on this equipment.

1.3 Water Chemistry

Water quality is extremely important for the optimum performance of your UV system. The following levels are recommended for installation:

Water Quality and Minerals	Level
Iron	< 0.3 ppm (0.3 mg/L)
Hardness*	< 7 gpg (120 mg/L)
Turbidity	< 1 NTU
Manganese	< 0.05 ppm (0.05 mg/L)
Tannins	< 0.1 ppm (0.1 mg/L)
UV Transmittance	> 75% (call factory for recommendations on applications where UVT < 75%)

* Where total hardness is less than 7 gpg, the UV unit should operate efficiently provided the quartz sleeve is cleaned periodically. If total hardness exceeds 7 gpg, the water should be softened. If your water chemistry contains levels in excess of those mentioned above, proper pre-treatment is recommended to correct these water problems prior to the installation of your UV disinfection system. These water quality parameters can be tested by your local dealer, or by most private analytical laboratories. *Proper pre-treatment is essential for the UV disinfection system to operate as intended.*

Section 2 General Information

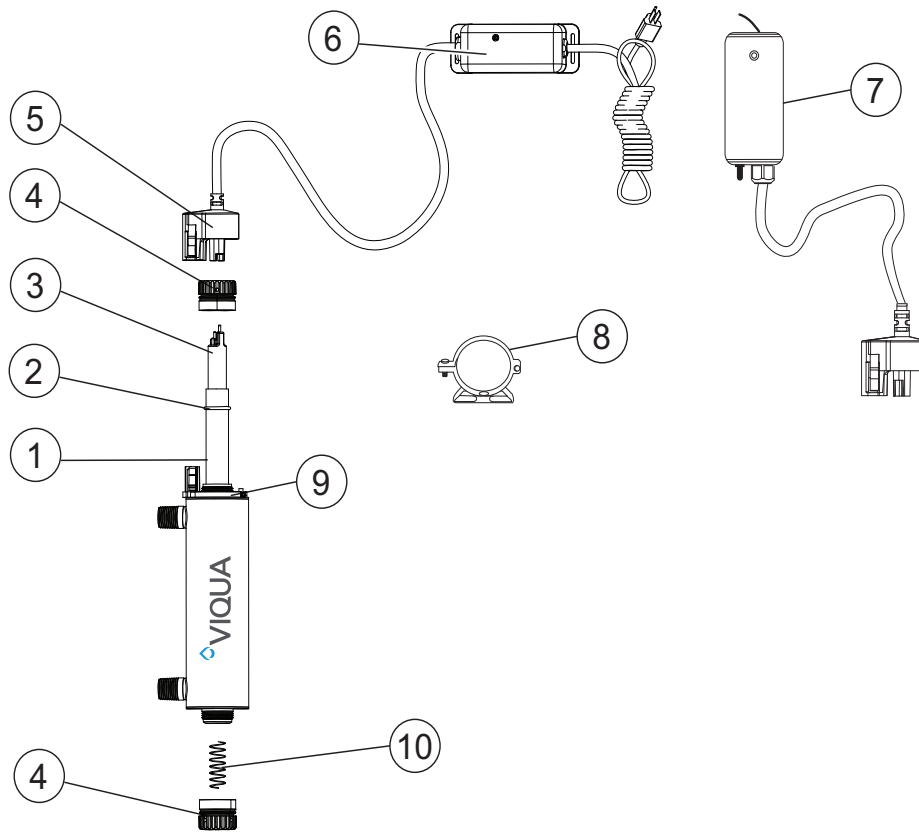

Figure 1 System Components

Item	Description	Part Number	UV Systems
1	Open-ended, GE 214 fused quartz sleeves with fire polished ends	QS-212	VT1, VT1/2, VT1/2A, VT1/2B, VT1/12, VT1/12/MEX
		QS-330	VT4, VT4/2, VT4/2A, VT4/2B, VT4/12, VT4/12/MEX
2	O-ring	410867	Used on all systems
3	Hard glass, coated Sterilume®-EX UV lamps for long, consistent life (9000 hours)	S212RL	VT1, VT1/2, VT1/2A, VT1/2B, VT1/12, VT1/12/MEX
		S330RL	VT4, VT4/2, VT4/2A, VT4/2B, VT4/12, VT4/12/MEX
4	Retaining nut	RN-001	Used on all systems
5	Lamp connector	-	-
6	Controller	BA-VT	VT1 and VT4
		BA-VT/2	VT1/2 and VT4/2
		BA-VT/2A	VT1/2A and VT4/2A
		BA-VT/2B	VT1/2B and VT4/2B
7	Controller (for 12VDC models only)	BA-RO/P/12	VT1/12, VT4/12, VT1/12/MEX and VT4/12/MEX
8	2.5" Mounting brackets	410958-R	Used on all systems
9	Lamp connector base	270276-R	Used on all systems
10	Spring	SP008	Used on all systems

Section 3 Installation

3.1 UV Disinfection System

⚠ CAUTION



Electronic controller must be connected to a Ground Fault Protected Circuit (GFCI) receptacle. Ensure green ground wire ring terminal is securely fastened to ground stud on UV chamber.

The ideal installation is vertical, with the inlet at the bottom and the outlet at the top (side).

- The controller should be mounted either above or beside the UV chamber. Always mount controller horizontally to prevent moisture from running down cordage and causing a potential fire hazard. Drip loops in all cordage connected to controller is highly recommended. Refer to [Figure 3](#).
- The complete water system, including any pressure or hot water tanks, must be sterilized before start up by flushing with chlorine (household bleach) to destroy any residual contamination. Refer to .
- The disinfection system is intended for indoor use only. Do not install disinfection system where it may be exposed to the weather.
- Install the disinfection system on cold water line only.
- A 5 micron sediment filter must precede the disinfection system. Ideally, the disinfection system should be the last treatment the water receives before it reaches the faucet.

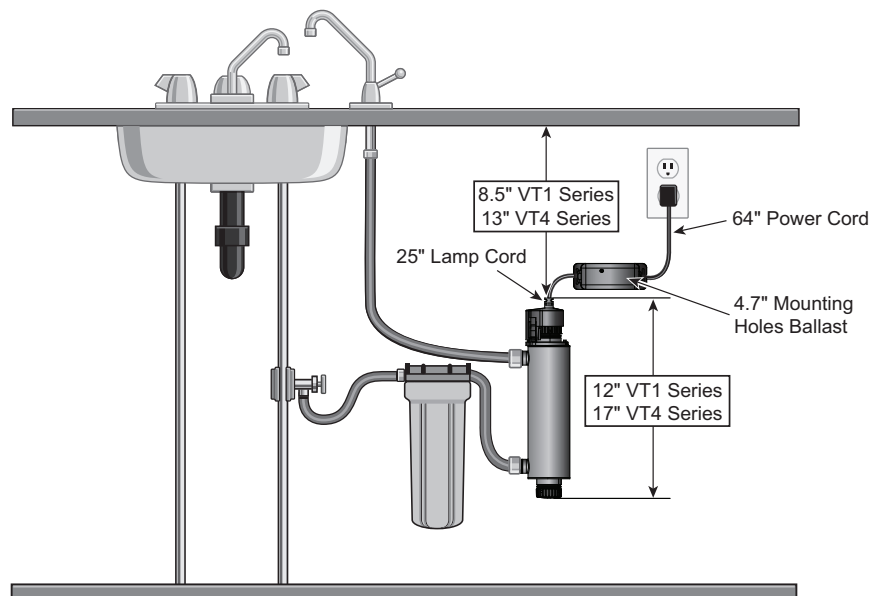

Figure 2 Disinfection System

Installation Procedure:

1. [Figure 2](#) shows the installation of a typical point of use (POU) system and the related components that may be used for the installation. The use of a by-pass assembly is recommended in case the system requires off-line maintenance. In this case, note the system requires a supplementary disinfection for the distribution system if any water is used during by-pass condition. In addition, during by-pass, the water will NOT be disinfected and a “DO NOT CONSUME THE WATER” tag should be physically installed on the by-pass assembly until such time as the system is sanitized and returned to service. For more information, refer to [Section 3.2](#). If the water is to be consumed while the system is off-line, the water must be boiled for two minutes prior to consumption.
2. Select a suitable location for the disinfection system and its related components. As it is required to install a GFCI, make sure that this is taken into consideration prior to any installation. Make sure you leave enough clearance above the system connector to facilitate lamp service (a length equal to the length of the unit should suffice).

3. Mount the system to the wall using the supplied clamps. Various connection methods can be used to connect the water source to the system, however union type connectors are recommended. In addition, the use of a by-pass assembly is recommended for emergency use of untreated water when your disinfection system is being serviced.

Notes: 1) When the UV unit is returned to service after being on by-pass, the complete water system must be disinfected once again with chlorine (household bleach) to destroy any contamination that may have entered the distribution system while on by-pass.

2) DO NOT solder connections while attached to the disinfection system, as this could damage the O-ring seals.

4. Mount the controller horizontally to the wall, near the UV chamber. Ideally place the controller above the chamber and away from any water connection point, to prevent any water from potentially leaking onto the controller by means of a leak at a connection point or a “sweating” system. Make sure you allow for a “drip-loop” as shown in Figure 3 on the UV lamp, UV sensor, and power cord, again, to prevent any water from potentially entering the controller.

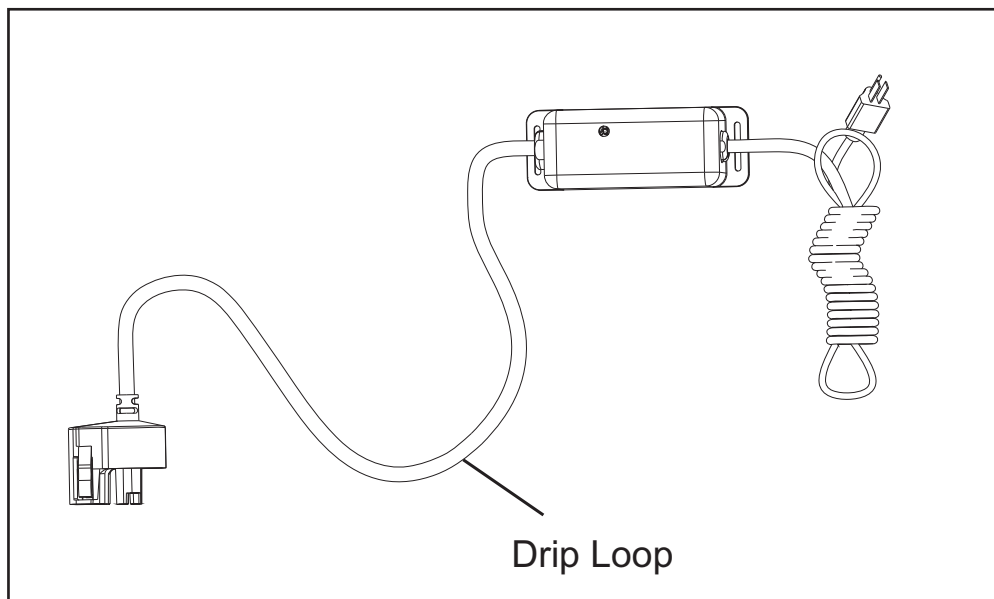

Figure 3 Drip Loop

5. For shipping purposes, the UV lamp is shipped in a separate cardboard tube. Remove the UV lamp from the shipping tube being careful not to touch the glass portion with your fingers. Insert the UV lamp into the quartz sleeve and chamber making sure the connection end is inserted last. Mount the disinfection system to the wall with the supplied clamp.
6. When all plumbing connections are complete, slowly turn on the water supply and check for leaks. The most likely cause of leaks is from the O-ring seal. In case of a leak, shut water off, drain cell, remove the retaining nut, wipe the O-ring and threads. Clean and re-install.
7. Once it is determined that there are no leaks, plug the system into the ground fault interrupter and check controller to ensure the system is operating properly. The controller should illuminate without any alarms.
8. Allow the water to run for a few minutes to clear any air or dust that may be in the UV chamber.

Note: When there is no flow, the water in the cell will become warm, as the UV lamp is always on. To remedy this, run a cold water tap anywhere in the house for a minute to flush out the warm water.

3.2 Disinfection Procedure

UV disinfection is a physical disinfection process and does not add any potentially harmful chemicals to the water. As UV does not provide a disinfection residual, it is imperative that the entire distribution system located after the UV be chemically disinfected to ensure that the plumbing system is free from any bacteriological contaminants. The disinfection process must be performed immediately after the UV unit is installed and repeated thereafter whenever the UV is shut down for service, without power, or inoperative for any reason. The procedure for sanitizing the plumbing system is readily accomplished as follows:

Installation

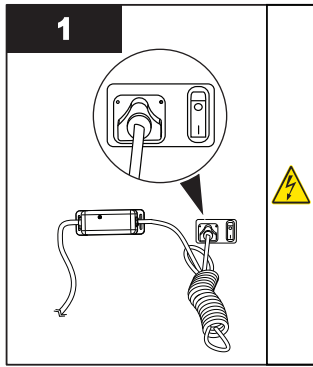

- Ensure the controller is plugged in for entire disinfection process.

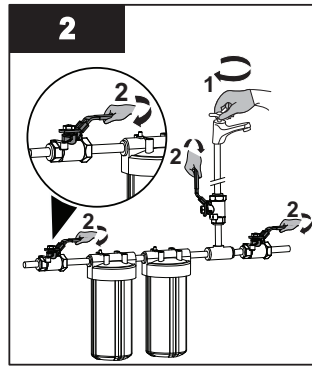

- Shut off the water supply.
- Close each faucet.

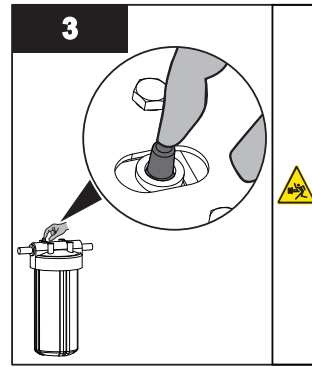

- Press the pressure button to release the pressure from the cartridges.

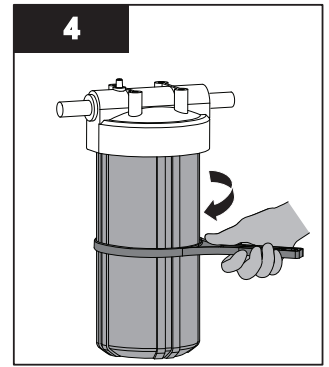

- Remove sump housing(s) using sump wrench.

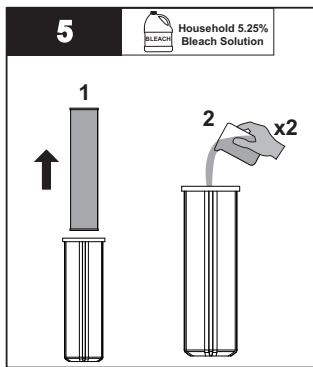

- Remove cartridge(s) and pour 2 cups of household bleach solution into the sump housing(s).

Note: DO NOT use Hydrogen Peroxide.

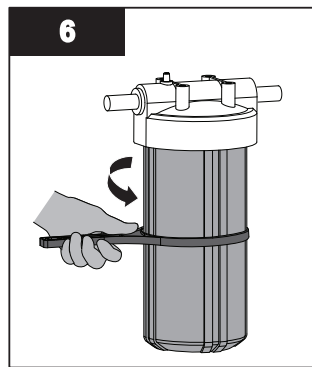

- Connect only the sump housing(s) to the unit.

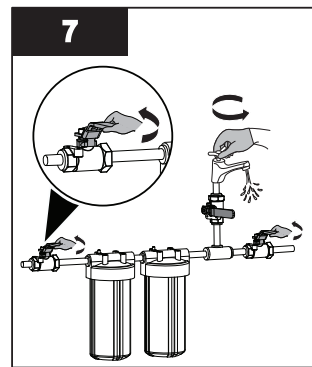

- Open each faucet and turn on water supply.
- Allow water to fill the chamber.

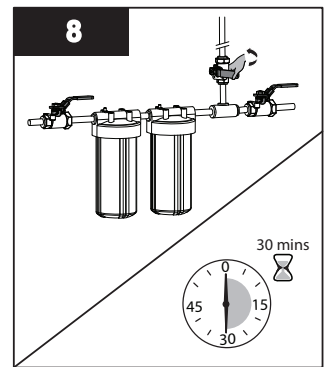

- Close all faucets and allow bleach to settle in the water lines for 30 minutes.

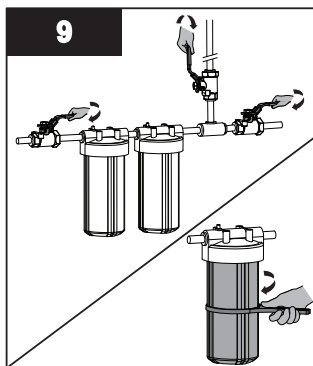

- With all faucets closed, remove sump housing(s) using sump wrench.

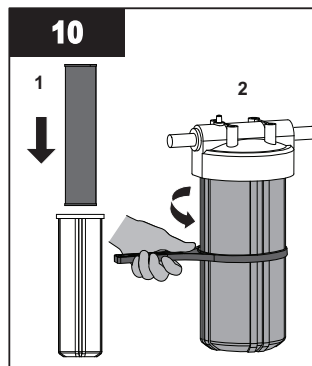

- Reinstall the cartridge(s) into sump housing(s) and connect to the unit.
- Flush all water outlets until bleach can no longer be smelled (at least 5 minutes).

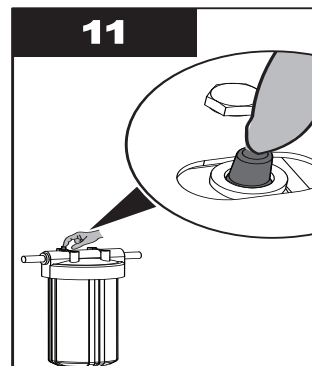

- Press the pressure button to purge air and to complete the disinfection procedure.

Notes: 1) The addition of chlorine (bleach) to a hot water tank that has in the past been fed with untreated raw water with high levels of other contaminants (iron, manganese, hydrogen sulphide, organics, etc.) will result in oxidation of these contaminants and may require repeated flushing of the hot water tank. This contingency must be dealt with independently under the start-up procedure for any other conditioners that may form a part of the pre-treatment for the UV unit.

2) The above disinfection procedure will result in a massive chlorine residual far in excess of the 0.5 to 1.0 mg/L typically present in municipally chlorinated water and of a magnitude consistent with the minimum 50 mg/L chlorine solution recommended for the disinfection of distribution systems known to be contaminated. Do not consume water until complete system has been flushed.

Section 4 Maintenance

⚠ WARNING



- Always disconnect power before performing any work on the disinfection system.
- Always shut-off water flow and release water pressure before servicing.
- Regularly inspect your disinfection system to ensure that the power indicators are on.
- Replace the UV lamp annually (or biennially if seasonal home use) to ensure maximum disinfection.
- Always drain the chamber when closing a seasonal home or leaving the unit in an area subject to freezing temperatures.

4.1 Replacing UV Lamp

NOTICE

- Refer to www.lamprecycle.org for UV lamp disposal.
- Do not use water during replacement of UV lamp.

Lamp replacement is a quick and simple procedure requiring no special tools. The UV lamp must be replaced after 9000 hours of continuous operation (approximately one year) in order to ensure adequate disinfection.

Procedure:

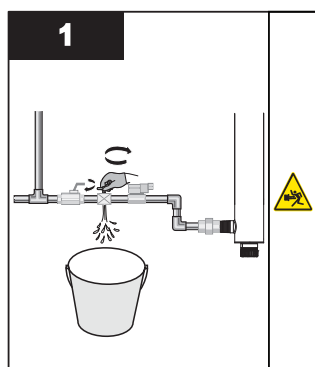

- Shut off the water line to UV chamber and release system pressure before servicing.

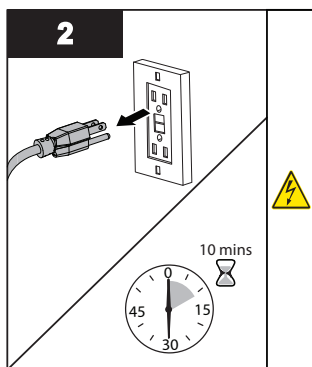

- Disconnect main power source and allow the unit to cool for 10 minutes.

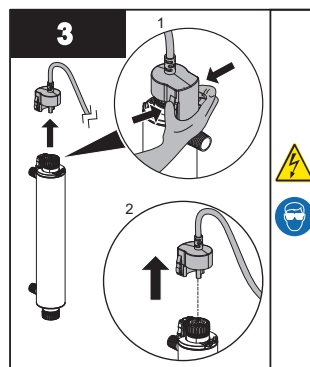

- Remove the lamp connector by squeezing the plastic locking tabs on the side of the connector.

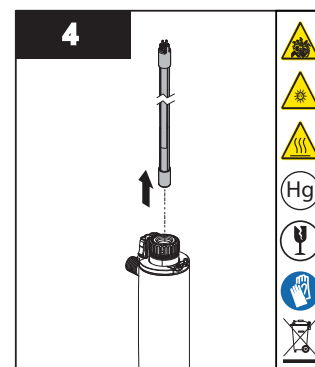

- Remove the UV lamp in upward direction from the UV chamber and lamp connector base.
- Hold the UV lamp at the ceramic ends.

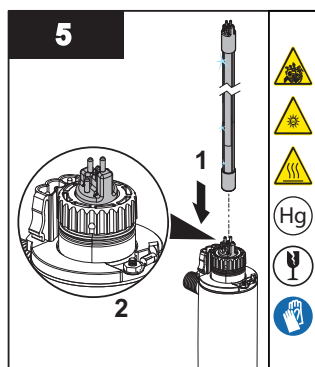

- Insert the new UV lamp fully into the UV chamber leaving about two inches of the UV lamp protruding from the UV chamber.

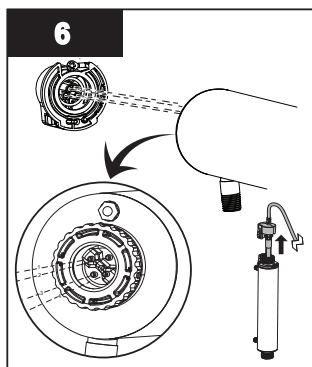

- Attach the connector to the UV lamp and note that the connector will only allow correct installation in one position.

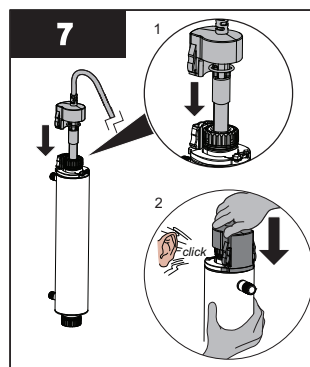

- Push the lamp connector against lamp connector base together until an audible click is heard.
- Restore power and re-pressurize the system to check for leaks.

4.2 Cleaning and Replacing Quartz Sleeve

Note: Minerals in the water slowly form a coating on the quartz sleeve. This coating must be removed because it reduces the amount of UV light reaching the water, thereby reducing disinfection performance. If the sleeve can not be cleaned, it must be replaced.

Prerequisites:

- Shut off water supply and drain the line.
- Place a small pail under the unit to catch any spills.
- Remove the UV lamp. Refer to [Section 4.1](#).

Procedure:

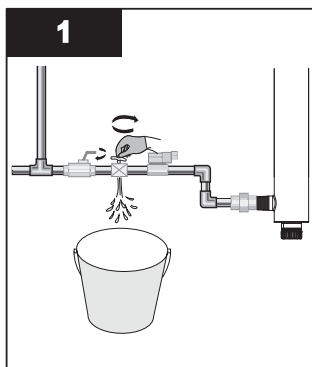

- Drain the UV chamber by using the drain port.

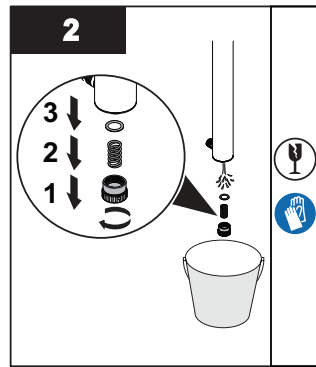

- Remove the bottom retaining nut, floating spring, and O-ring.

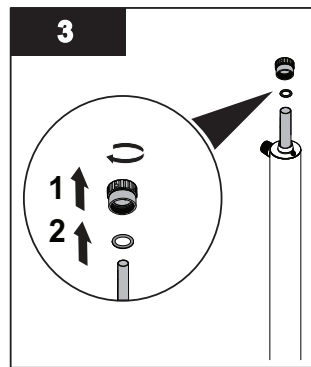

- Remove the top retaining nut and O-ring.

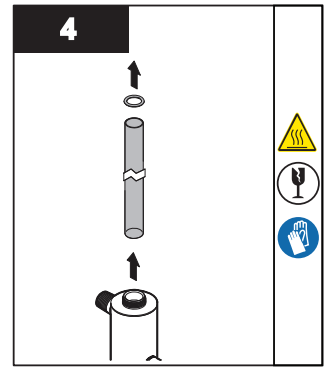

- Carefully, remove O-ring adhering to the quartz sleeve.
- Remove the quartz sleeve.



- Clean the quartz sleeve with a cloth soaked in CLR, vinegar or some other mild acid and then rinse with water.

Note: If sleeve cannot be completely cleaned or it is scratched or cracked, then replace the sleeve.

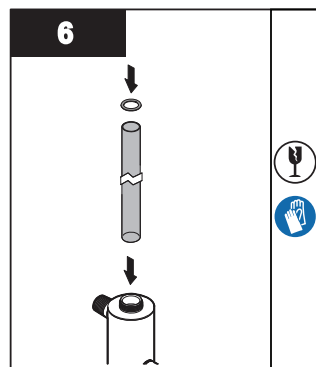

- Reinstall the quartz sleeve in the UV chamber allowing the sleeve to protrude at equal distance on both ends of the UV chamber.

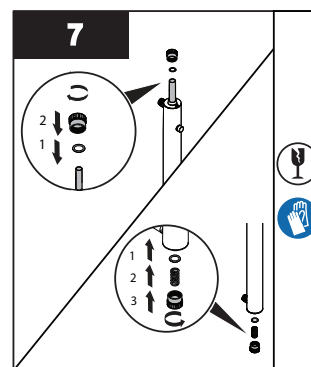

- Reinstall the top and bottom retaining nuts, floating spring, and O-rings respectively.
- When service is complete, assemble the prerequisites in the reverse order of disassembly.

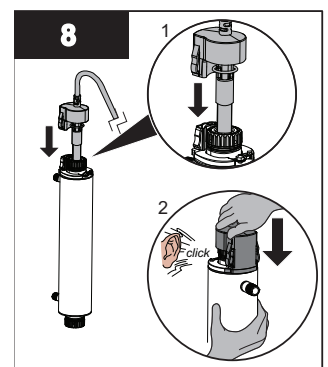

- Push the lamp connector against lamp connector base together until an audible click is heard.
- Plug in controller and verify the POWER-ON LED display is illuminated.
- Re-pressurize the system to check for leaks.

Notes: 1) After replacing the UV lamp or quartz sleeve, perform the disinfection procedure, refer to [Section 3.2](#).

2) If the system is put on a temporary by-pass or if it becomes contaminated after the disinfection system, it is necessary to shock the system with household bleach for a full 20 minutes before resuming the use of the water.

Section 5 Specifications

Model		VT1, VT1/12		VT1/2, VT1/2A, VT1/2B		VT4, VT4/12		VT4/2, VT4/2A, VT4/2B	
Flow Rate ¹	US Public Health 16mJ/cm ²	2 gpm (7.5 lpm) (0.45 m ³ /hr)		2 gpm (7.5 lpm) (0.45 m ³ /hr)		6.5 gpm (24 lpm) (1.4 m ³ /hr)		6.5 gpm (24 lpm) (1.4 m ³ /hr)	
	VIQUA Standard 30 mJ/cm ²	1 gpm (4 lpm) (0.24 m ³ /hr)		1 gpm (4 lpm) (0.24 m ³ /hr)		3.5 gpm (13 lpm) (0.8 m ³ /hr)		3.5 gpm (13 lpm) (0.8 m ³ /hr)	
	NSF/EPA 40mJ/cm ²	0.5 gpm (2 lpm) (0.12 m ³ /hr)		0.5 gpm (2 lpm) (0.12 m ³ /hr)		2.5 gpm (9 lpm) (0.6 m ³ /hr)		2.5 gpm (9 lpm) (0.6 m ³ /hr)	
Dimensions	Length	20.3 cm (8")		20.3 cm (8")		32 cm (12.6")		32 cm (12.6")	
	Cell Diameter	6.5 cm (2.5")		6.5 cm (2.5")		6.5 cm (2.5")		6.5 cm (2.5")	
Inlet/Outlet Port Size		Combo 1/2" MNPT/3/8" FNPT		Combo 1/2" MNPT/3/8" FNPT		1/2" MNPT		1/2" MNPT	
Shipping Weight		1.8 kg (4 lbs)		1.8 kg (4 lbs)		2.9 kg (6.5 lbs)		2.9 kg (6.5 lbs)	
Electrical	Voltage	100-140 V / 50/60 Hz	12 VDC	200-240 V / 50/60 Hz		100-140 V / 50/60 Hz	12 VDC	200-240 V / 50/60 Hz	
	Max. Current	0.28 Amp	1.8 Amp	0.16 Amp		0.28 Amp	1.8 Amp	0.16 Amp	
	Power Consumption	13 W	13 W	13 W		19 W	19 W	19 W	
	Lamp Watts	9 W	9 W	9 W		15 W	15 W	15 W	
Maximum Operating Pressure		125 psi (861 kPa)		125 psi (861 kPa)		125 psi (861 kPa)		125 psi (861 kPa)	
Minimum Operating Pressure		5 psi (34 kPa)		5 psi (34 kPa)		5 psi (34 kPa)		5 psi (34 kPa)	
Ambient Water Temperature		2-40 °C (36-104 °F)		2-40 °C (36-104 °F)		2-40 °C (36-104 °F)		2-40 °C (36-104 °F)	
Lamp Type		Sterilume™-EX (standard-output)		Sterilume™-EX (standard-output)		Sterilume™-EX (standard-output)		Sterilume™-EX (standard-output)	
Visual "Power-On"		Yes		Yes		Yes		Yes	
Visual Lamp		Yes		Yes		Yes		Yes	
Chamber Material		304 SS		304 SS		304 SS		304 SS	
¹ Flow rates based on UVT ₁₀ =95%									
Units ending in "MEX" meet the requirements established in the Mexican Official Norm NOM-244-SSA1-2008									

Section 6 Manufacturer's Warranty

Our Commitment

VIQUA is committed to ensuring your experience with our products and organization exceeds your expectations. We have manufactured your UV disinfection system to the highest quality standards and value you as our customer. Should you need any support, or have questions about your system, please contact our Technical Support team at 1.800.265.7246 or technicalsupport@viqua.com and we will be happy to assist you. We sincerely hope you enjoy the benefits of clean, safe drinking water after the installation of your VIQUA disinfection system.

How to Make a Warranty Claim

Note: *To maximise the disinfection performance and reliability of your VIQUA product, the system must be properly sized, installed and maintained. Guidance on the necessary water quality parameters and maintenance requirements can be found in your Owner's Manual.*

In the event that repair or replacement of parts covered by this warranty are required, the process will be handled by your dealer. If you are unsure whether an equipment problem or failure is covered by warranty, contact our Technical Support team at 1.800.265.7246 or e-mail technicalsupport@viqua.com. Our fully trained technicians will help you troubleshoot the problem and identify a solution. Please have available the model number (system type), the date of purchase, the name of the dealer from whom you purchased your VIQUA product ("the source dealer"), as well as a description of the problem you are experiencing. To establish proof of purchase when making a warranty claim, you will either need your original invoice, or have previously completed and returned your product registration card via mail or online.

Specific Warranty Coverage

Warranty coverage is specific to the VIQUA range of products. Warranty coverage is subject to the conditions and limitations outlined under "[General Conditions and Limitations](#)".

Ten-Year Limited Warranty for VIQUA UV Chamber

VIQUA warrants the UV chamber on the VIQUA product to be free from defects in material and workmanship for a period of ten (10) years from the date of purchase. During this time, VIQUA will repair or replace, at its option, any defective VIQUA UV chamber. Please return the defective part to your dealer who will process your claim.

Three-Year Limited Warranty for Electrical and Hardware Components

VIQUA warrants the electrical (controller) and hardware components to be free from defects in material and workmanship for a period of three (3) years from the date of purchase. During this time, VIQUA will repair or replace, at its option, any defective parts covered by the warranty. Please return the defective part to your dealer who will process your claim.

One-Year Limited Warranty for UV lamps, Sleeves, and UV Sensors

VIQUA warrants UV lamps, sleeves, and UV Sensors to be free from defects in material and workmanship for a period of one (1) year from the date of purchase. During this time, VIQUA will repair or replace, at its option, any defective parts covered by the warranty. Your dealer will process your claim and advise whether the defective item needs to be returned for failure analysis.

Note: *Use only genuine VIQUA replacement lamps and sleeves in your system. Failure to do so may seriously compromise disinfection performance and affect warranty coverage.*

General Conditions and Limitations

None of the above warranties cover damage caused by improper use or maintenance, accidents, acts of God or minor scratches or imperfections that do not materially impair the operation of the product. The warranties also do not cover products that are not installed as outlined in the applicable Owner's Manual.

Parts repaired or replaced under these warranties will be covered under warranty up to the end of the warranty period applicable to the original part.

The above warranties do not include the cost of shipping and handling of returned items. The limited warranties described above are the only warranties applicable to the VIQUA range of products. These limited warranties outline the exclusive remedy for all claims based on a failure of or defect in any of these products, whether the claim is based on contract, tort (including negligence), strict liability or otherwise. These warranties are in lieu of all other warranties whether written, oral, implied or statutory. Without limitation, no warranty of merchantability or of fitness for a particular purpose shall apply to any of these products.

VIQUA does not assume any liability for personal injury or property damage caused by the use or misuse of any of the above products. VIQUA shall not in any event be liable for special, incidental, indirect or consequential damages. VIQUA's liability shall, in all instances, be limited to repair or replacement of the defective product or part and this liability will terminate upon expiration of the applicable warranty period.



425 Clair Rd. W, Guelph, Ontario, Canada N1L 1R1
t. (+1) 519.763.1032 • tf. (+1) 800.265.7246 (US and Canada only)
t. (+31) 73 747 0144 (Europe only) • f. (+1) 519.763.5069
e-mail: info@viqua.com
www.viqua.com